

Cybercopter Flyer

Henry V. Pham
A. Introduction

The **Cybercopter Flyer** is invented with State of The Art design to provide the nice looking and easy to fly with a safety flyer in round shape like UFO which is intended to replace the existing helicopter and vertical takeoff and landing aircrafts. The existing helicopter with the blades spinning around on top which is covered about 5 meters in diameter is dangerous when the blades touching anything and more likely the helicopter fails to keep balance and crashes easily.

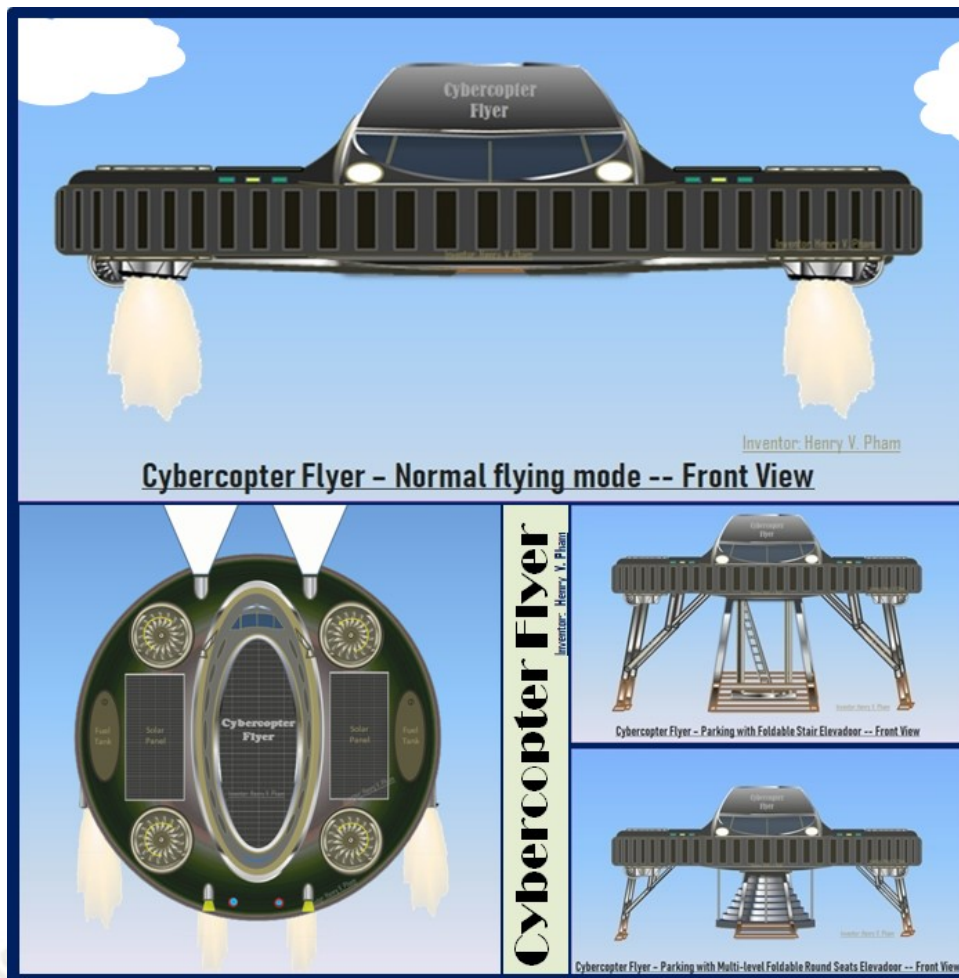

Figure-A1: Cybercopter Flyer - Overview

The Cybercopter Flyer is invented with 4 main lift up engines which can be turbofan, turbojet or more advanced engines; and the 2 main turning and pushing side engines which are used to turn left or right while flying, with plus of the 2 additional pushing engines on the back to help the flyer flying faster. The Cybercopter Flyer can hover more stable than helicopter with the 4 lift up engines within the pumping protection ring and much safer than helicopter, better for highway patrol, great for rescuing, stronger for lifting, good to fly for sightseeing, great for sky diving in larger shape for military versions. The Cybercopter Flyer can be built with bigger shape and have up to 12 engines which can be used for heavy duty carrying or large transformation with great advantage of vertical takeoff and landing with the great Standier. The above **Figure-A1: Cybercopter Flyer - Overview** shows the overview of the Cybercopter Flyer.

Cybercopter Flyer

The Cybercopter Flyer would come with many different versions. The Electrical Powered Cybercopter Flyer version with only turbofan engines, use only electrical power which can be charged anywhere with provided electrical power charger and with solar power with solar panel on top surface of the Cybercopter Flyer. The Hybrid Powered Cybercopter Flyer version would come with the 4 lifting turbofan engines, and the side turning and back pushing engines can be turbojet engines which would use liquid fuel to burn the intake air for propulsion. The Liquid Fuel Cybercopter Flyer version would come with all turbojet engines for bigger shapes which are used to burn the intake air for propulsion. The Cybercopter Flyer would be built to fly like driving a car to keep the normal driving behaviors with steering wheel yoke and pedals; push on the speed pedal to fly forward; push on the brake pedal to slow down; and plus an up/down joystick for takeoff and landing. With the recommendation of replaceable engine modules for any aircraft, any airplane or any flyer; the Cybercopter Flyer is the great promise for the future of air transportation with vertical takeoff and landing which is in high demand for the human world today for personal use with easy flying, good for border police patrolling, great for high rank military personnel whom needs to fly for patrolling or for camp or aircraft carrier visiting, and great to replace all the duties that are currently used with the existing helicopters.

B. Cybercopter Flyer Top View

The Cybercopter Flyer would come with the 4 main vertical thruster engines located right at the 4 corners of the magic square of the circle. The front left and back left thruster engines spin in clockwise, and the front right and the back right thruster engines spin in counter clockwise; the desired spinning directions for these engines are purposely making the Cybercopter Flyer flying more stabilized with compensate momentums of the 4 spinning motors. The below Figure-B1: Cybercopter Flyer - Top view shows the top view of the Cybercopter Flyer with 4 main vertical thruster engines and their spinning directions. These 4 vertical thruster engines can be tilted and used as pushing engines for forwarding when flying faster or for backward thrusters for stopping during the flying. For bigger Cybercopter Flyer, it is recommended to build with 12 vertical thrust engines with 3 engines in one corner for stronger lift up and for better backup engines. The 2 main side pushing/turning engines are shown on the half bottom side with labeled as 'Horizontal Push/Turning Thruster'. Additional 2 pushing engines as shown the thruster labeled as 'Additional Horizontal Push Thruster'. The Cybercopter Flyer would come with Solar panels on top surface which is recommended for all versions that can be used electrical power for utilities, lights and other purposes; for Electrical Powered Cybercopter Flyer version, this is great electrical power charging during fly to keep the engines running; Cybercopter Flyer in circle shape with more open space compare to any other aircrafts or airplanes on top, that provides great for Solar power. The fuel tanks are shown on both sides of the flyer which are used for the Hybrid and Fuel Powered Cybercopter Flyer versions. Like car, the Cybercopter Flyer is recommended to have back view cameras on both sides as labeled 'Back View Camera' to provide the back views for the pilot to check the top engines sides and for other purposes. The Cybercopter Flyer would have 2 head lights as shown and the tail lights; and the windshield and windows are recommended to build with State-of-the-Art for nice looking, better viewing and high reliability.

Cybercopter Flyer

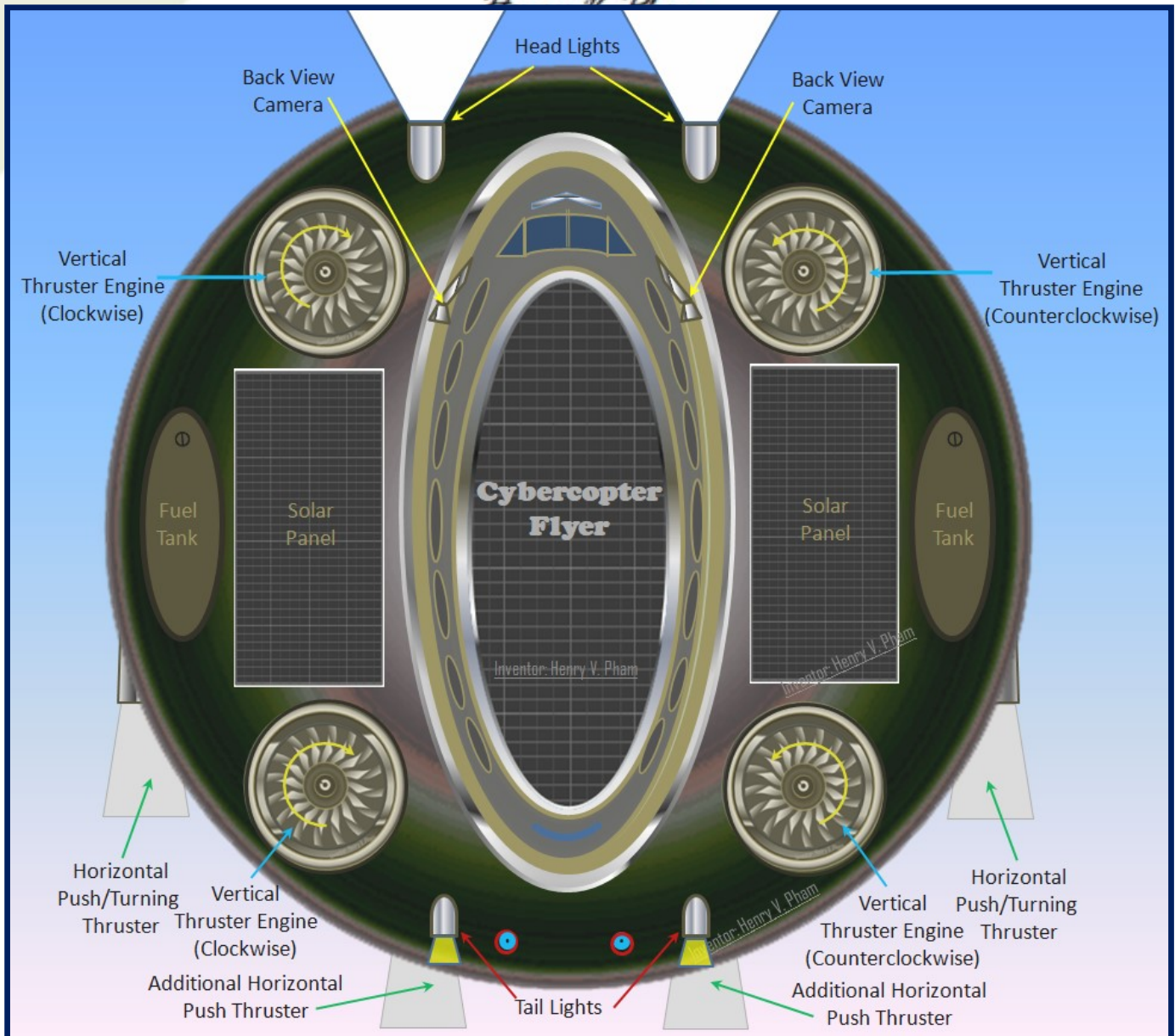

Figure-B1: Cybercopter Flyer - Top view

C. Cybercopter Flyer Side View

The below Figure-C1: Cybercopter Flyer - Side view shows the side view of the Cybercopter Flyer with Emergency door, one on each side, which is open upward to prevent stuck door when the fly is crashed and upside down. The engines thrusters are shown with the directions of the thrusts in normal flying mode. The Cybercopter Flyer would come with ring bumper with shock sensors around to detect shocks and determine the touch area; the shock sensors will show more detail in later sections. The Cybercopter Flyer would come with the balance sensors and the stabilization system that controls the flyer and keep the flyer balance during fly and during detecting shocks when the flyer hits on any obstacles.

Cybercopter Flyer

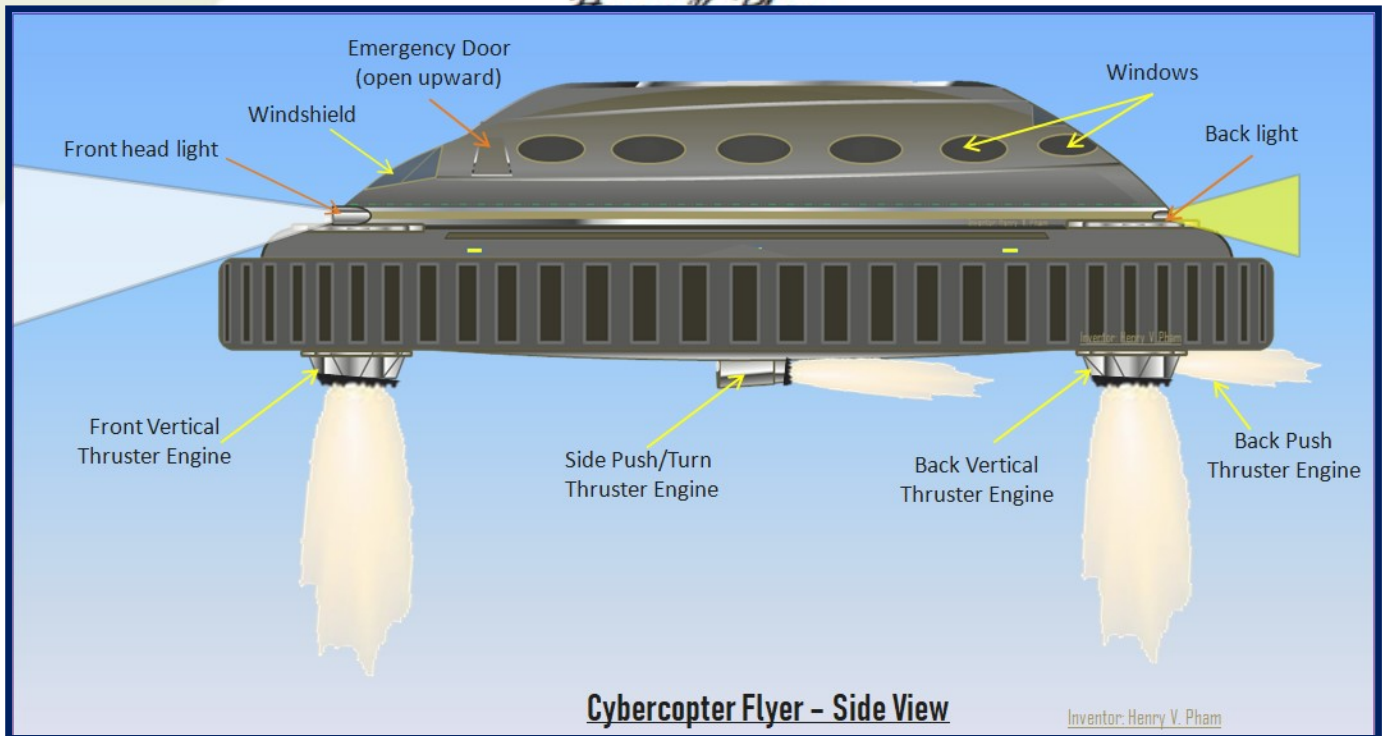

Figure-C1: Cybercopter Flyer - Side view

D. Cybercopter Flyer Bottom View

The below **Figure-D1: Cybercopter Flyer - Bottom view** shows the bottom view of the Cybercopter Flyer with the 4 vertical thrust engines locations, the 4 foldable standiers, 6 recommended cameras and lights, bottom opener elevadoor, and the luggage storages. The Cybercopter Flyer would come with 4 foldable standiers which can come with traditional foldable legs or other safe and suitable legs for Cybercopter Flyer are acceptable, however, the vertical takeoff flyer with round shape requires balance of engines to takeoff and this is critical to have better foldable legs or standiers. The foldable standier in this invention document is designed so that the Cybercopter Flyer can able to land with the 2 crossing standiers if the others are failed to unfold; this is the great standier that would be used in Cybercopter Flyer. The standiers will be shown more details in later sections. The 4 cameras which are pointing toward the 4 vertical thrust engines in 120° degrees, are used to check the engines and good enough to check the standiers for unfolding while landing; plus a camera on the back for safety purposes; these cameras can be fixed built. The Cybercopter Flyer would come with a front zoom-able and controllable camera which is used to view and watch the ground from high altitude during fly for safety and for other purposes. This camera is good for news reporters, great for highway patrol and border patrol, and great for military services. The Cybercopter Flyer is recommended to have dimmable LED lights layout in ring at the bottom of the flyer to help identify round flying object; the LED lights are brighter when the flyer is about to land to provide better view at night, and dimmer while flying. The luggage storages are recommended to build on both sides for better balance as shown in this figure. Another important thing of the Cybercopter Flyer is the Elevadoor which provides the door for pilot and passengers to get to the ground from the flyer; the elevadoor would come with different versions and will be shown more detail in later sections.

Cybercopter Flyer

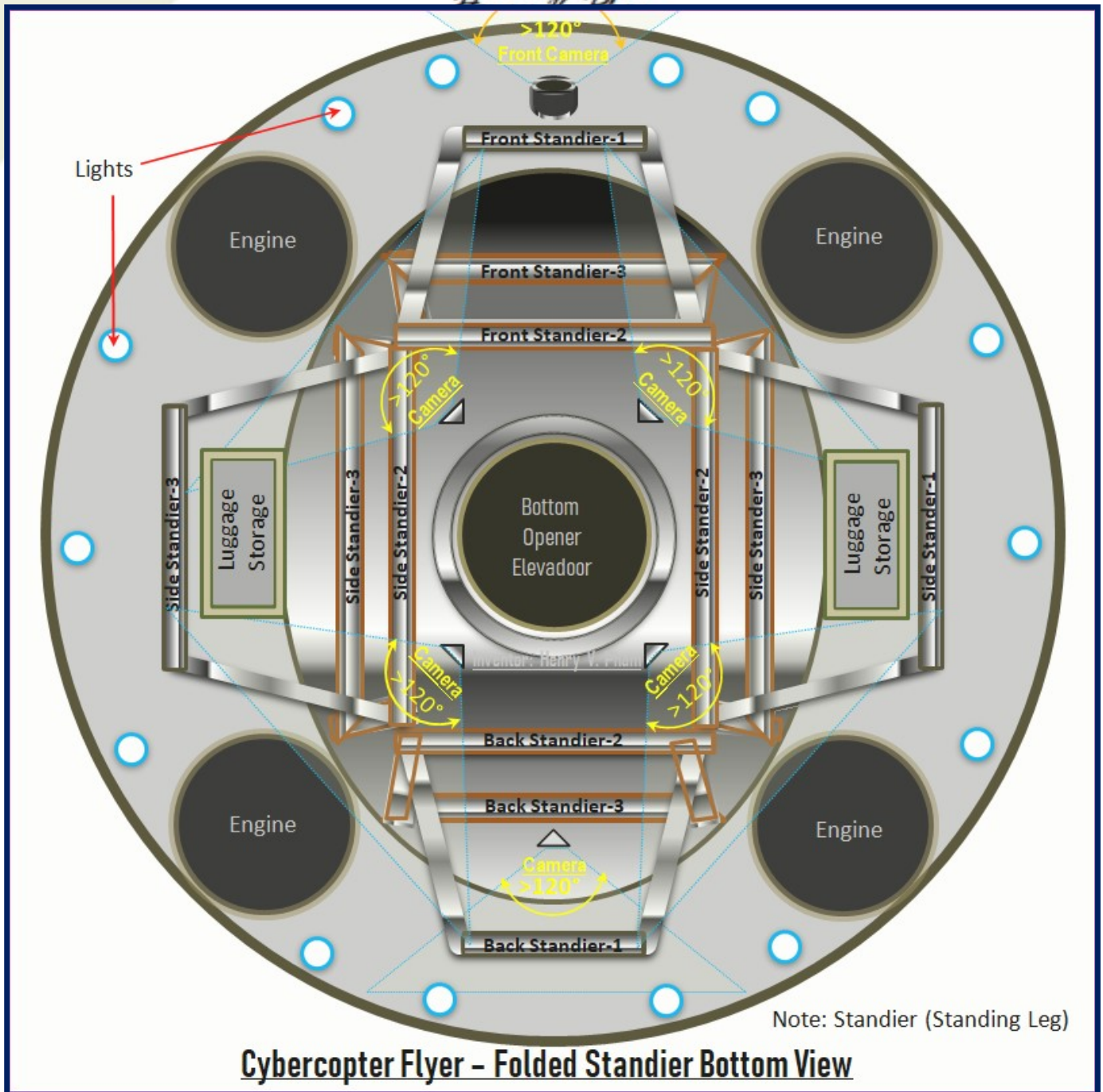

Figure-D1: Cybercopter Flyer - Bottom view

E. Cybercopter Flyer Frame Structure

Figure-E1: Cybercopter Flyer - Engines & Inner Floor Layout below shows the engines layout and the inner floor shape layout of the Cybercopter Flyer. The Cybercopter Flyer with radius R ; the Engine radius r ; Inner Circle Base Frame Radius R' , then the floor shape is recommended within the ellipse and the inner circle shapes. The magic square of the circle with radius R is the square with side equals to $R\sqrt{2}$. The green rectangle is drawn within the 4-engines frames to cover head and tail which the ellipse curve should touch on the border, and the ellipse curve should touch the edge of the 4-engines frames; note that the drawing

Cybercopter Flyer

in this invention with the floor in ellipse shape. The Cybercopter Flyer can be built as small as possible that can fit one or two person for personal use with the same or similar floor layout. The 4 vertical thrust engines are layout and shown at the corners of magic square in dash orange; and the elevadoor is located at the center of the flyer. Note that for larger size of Cybercopter Flyer, the exit doors can be in different shapes.

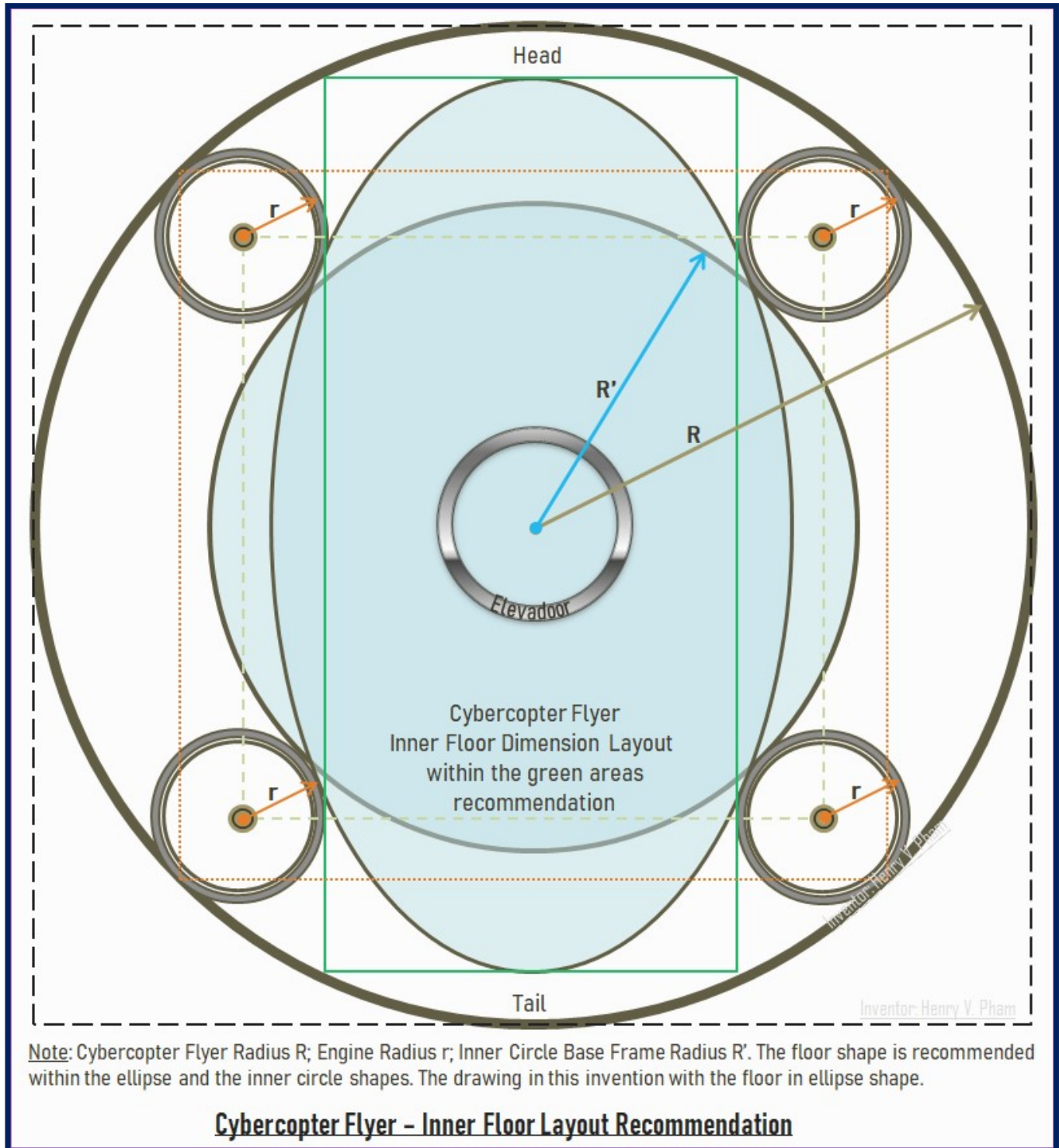

Note: Cybercopter Flyer Radius R ; Engine Radius r ; Inner Circle Base Frame Radius R' . The floor shape is recommended within the ellipse and the inner circle shapes. The drawing in this invention with the floor in ellipse shape.

Cybercopter Flyer – Inner Floor Layout Recommendation

Figure-E1: Cybercopter Flyer – Engines & Inner Floor Layout

Cybercopter Flyer

Figure-E2: Cybercopter Flyer - 12 Engines & Inner Floor Layout below shows similar layout with the above figure but with 12 vertical thrust engines, 3 engines in one location. The 12 engines Cybercopter Flyer is recommended for big size and for heavy duty lifting; and more than 4 standiers can be built for big Cybercopter Flyer with more space on top and bottom of the flyer.

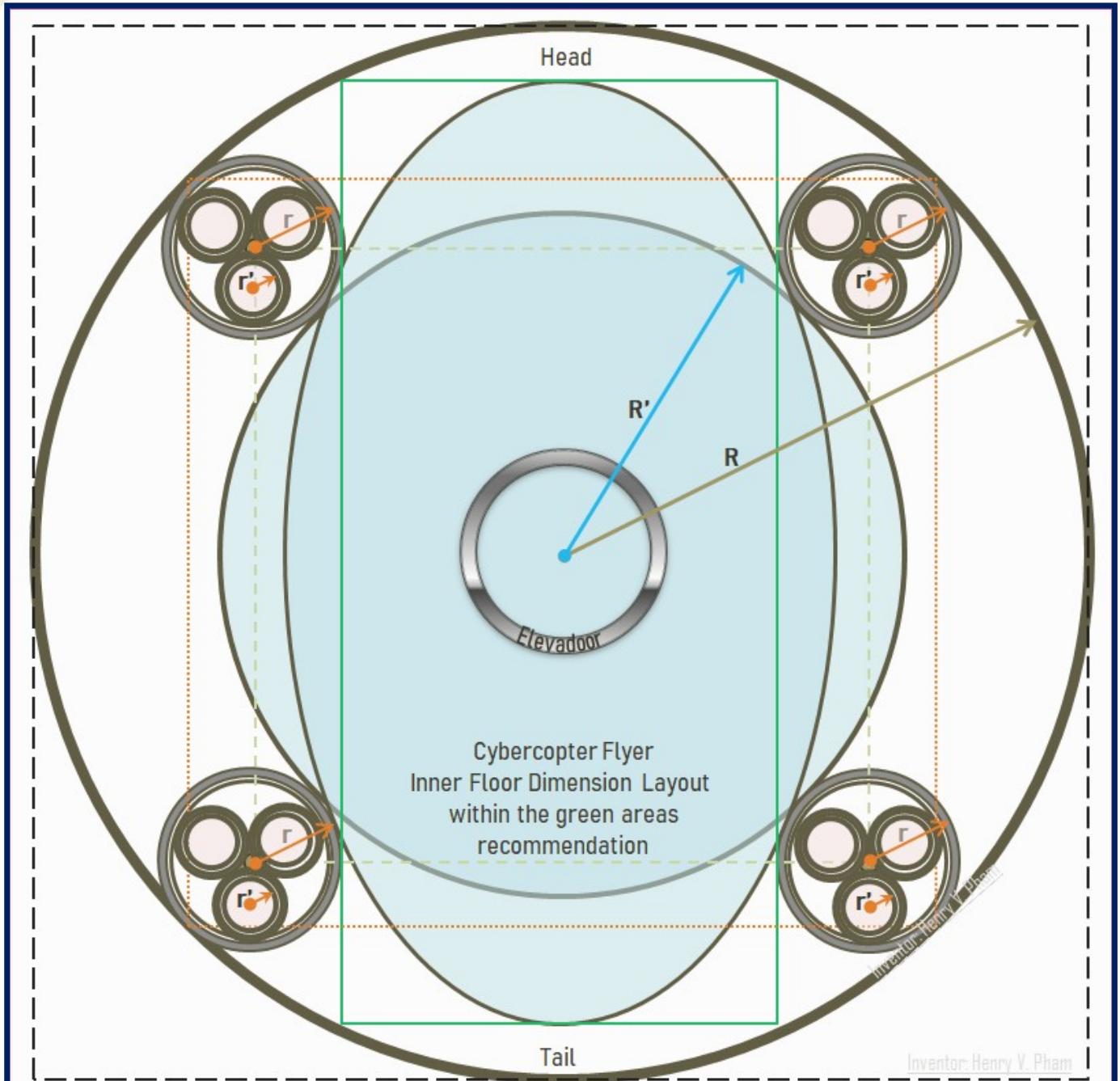

Note: For big size of Cybercopter Flyer Radius R ; 3 Engines with Radius r' within circle radius r ; Inner Circle Base Frame Radius R' . The floor shape is recommended within the ellipse and the inner circle shapes. The drawing in this invention with the floor in ellipse shape.

Cybercopter Flyer - Big size Cybercopter flyer with 12 engines Recommendation

Figure-E2: Cybercopter Flyer - 12 Engines & Inner Floor Layout

Cybercopter Flyer

Figure-E3: Cybercopter Flyer - Outer Shock Sensors Ring Layout below shows shock sensors layout zones. The Cybercopter Flyer is recommended to divide into 8 shock sensor zones, and each zone can be divided more subzones for big size versions. The shock detection and stabilization systems would be easy and better to detect and control to keep the flyer stable.

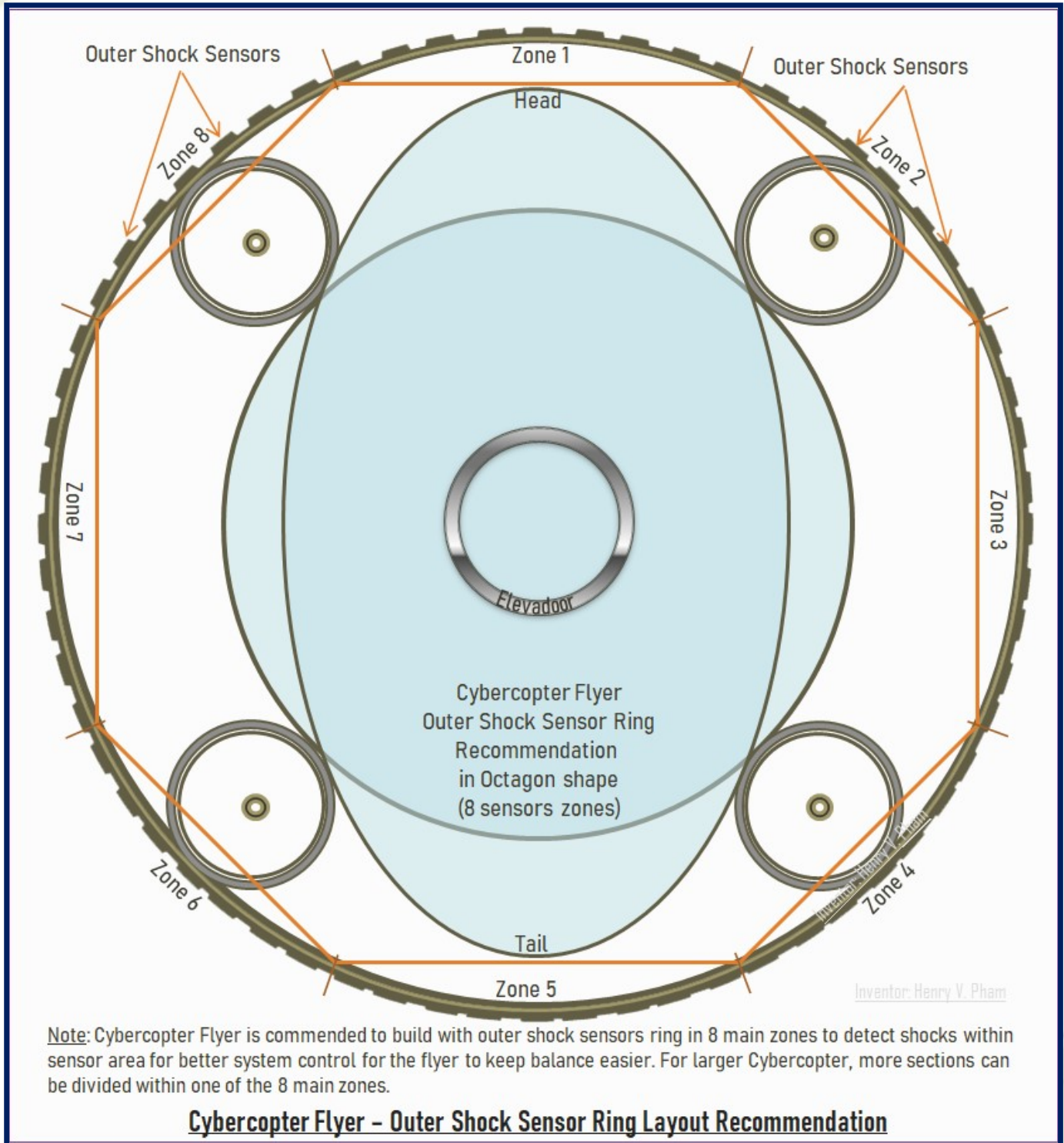

Figure-E3: Cybercopter Flyer - Outer Shock Sensors Ring Layout

Cybercopter Flyer

Figure-E4: Cybercopter Flyer – Frame Structure Layout (Top view) below shows the top view of the frame structure layout. The layout shows the Cybercopter Flyer floor base in black ellipse with the elevaddoor at the center, the 4 vertical thrust engines frame layout, the side engines supporter frames layout. There are front and back supporters frames layout showing on top and bottom of the drawing respectively. The outer circle frame is the main protection frame as shown to protect entire flyer with plus of an inner circle frame which is used to protect the structure and connect the standiers. The circle shape is the great bonding structure shape, and the Cybercopter Flyer is built in circle shape would have strong protection with the outer ring frame plus the supporters from the inner to form a great shape for flying object with great support of shock sensors and stabilization systems.

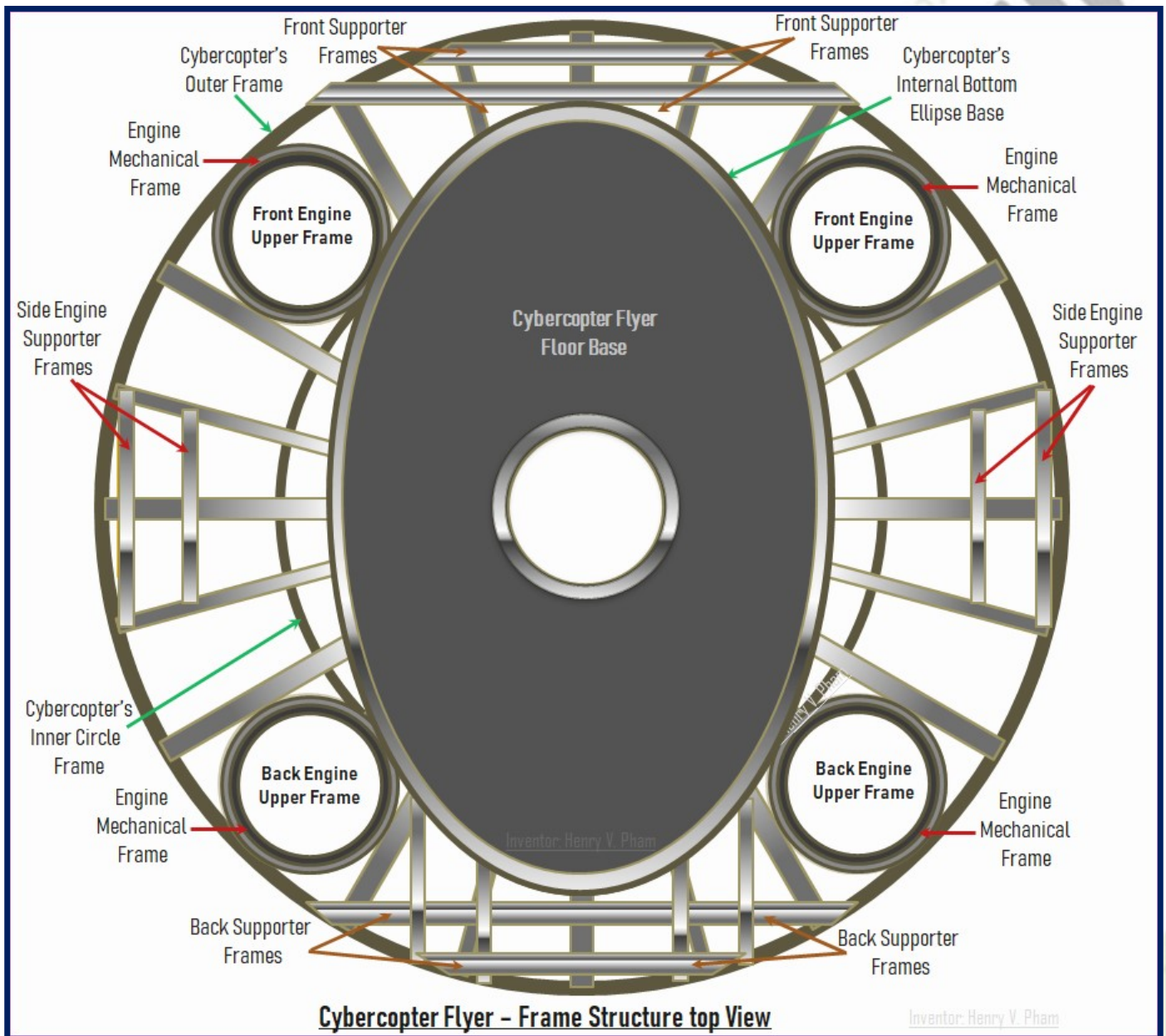

Figure-E4: Cybercopter Flyer – Frame Structure Layout (Top view)

Cybercopter Flyer

The below **Figure-E5: Cybercopter Flyer – Frame Structure Top Roof Layout** shows frame structure of the top roof section. The Cybercopter Flyer Elevadoor is recommended in circle for common regular sizes, and the top roof is also recommended to have circle structure to build and handle Elevadoor mechanism easier. The top roof shows the supporters from the top center down to the body frames in round shape structure which is the strong bonding structure to provide better protection for entire flyer. The front windshield may have supporter at the center for larger sizes to protect the flyer windshield better as long as the pilot and front seat views are widely enough to view with recommendation of 180° viewing angle.



Figure-E5: Cybercopter Flyer – Frame Structure Top Roof Layout

Cybercopter Flyer

The Cybercopter Flyer structure frames with the top roof that shows entire flyer structure in top view as shown in **Figure-E6: Cybercopter Flyer - Frame Structure with Top Roof (Top view)**. The top roof curved frame structure is recommended to build with nicely fit gradually wider at the bottom to connect to the body frames with State-of-the-Art design for nice look-and-feel and strong protection with titanium lightweight material. Note that the top roof is recommended to be flat surface which is used to install solar panels for better solar light coverage. The below figure shows the Cybercopter Flyer windshield on top of the drawing and the front supporters frames as shown in previous sections. The other supporter frames and the engines frames plus the inner and outer structures in this figure are also shown in the previous sections as mentioned above.

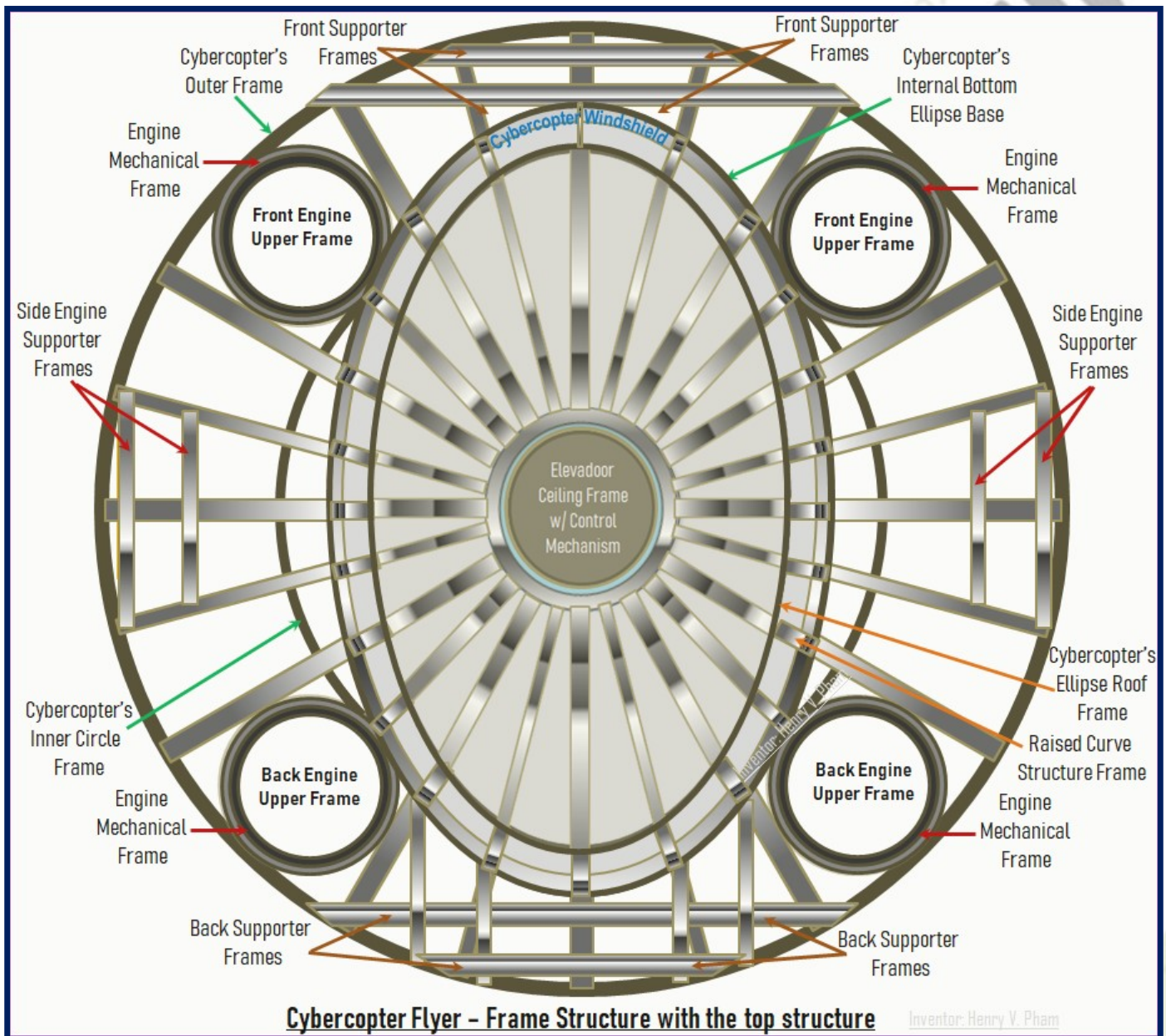

Figure-E6: Cybercopter Flyer - Frame Structure with Top Roof (Top view)

Cybercopter Flyer

The bottom frame structure is also important and need to build with strong bonding structures as shown in **Figure-E7: Cybercopter Flyer – Frame Structure (Bottom view)** below. This figure shows the frame structures of the 4 standiers as shown in the crossed shapes with the bottom opener Elevadoor at center; plus the luggage storage frames within the 2 standiers side frames. The 4 vertical thrust engines bottom frames are shown in circle shapes at the 4 corners of the magic square of the outer circle frame; the 4-engines frames are recommended to build within the inner circle frame and the outer circle frame structures. The side engines frame structures are shown in rectangle close to the edge on both sides of the flyer structure. The additional 2 back pushing engines frames are shown in rectangle at the tail at the bottom of the drawing. The bottom opener Elevadoor is shown at the center of the entire frame structure; this Elevadoor is important for pilot and passengers access to or get off the flyer. For larger Cybercopter Flyer versions with bigger spaces, the elevadoor is also recommended to build at the center, and other exit doors can be built around the elevadoor with foldable stairs like the traditional stairs in existing airplanes.

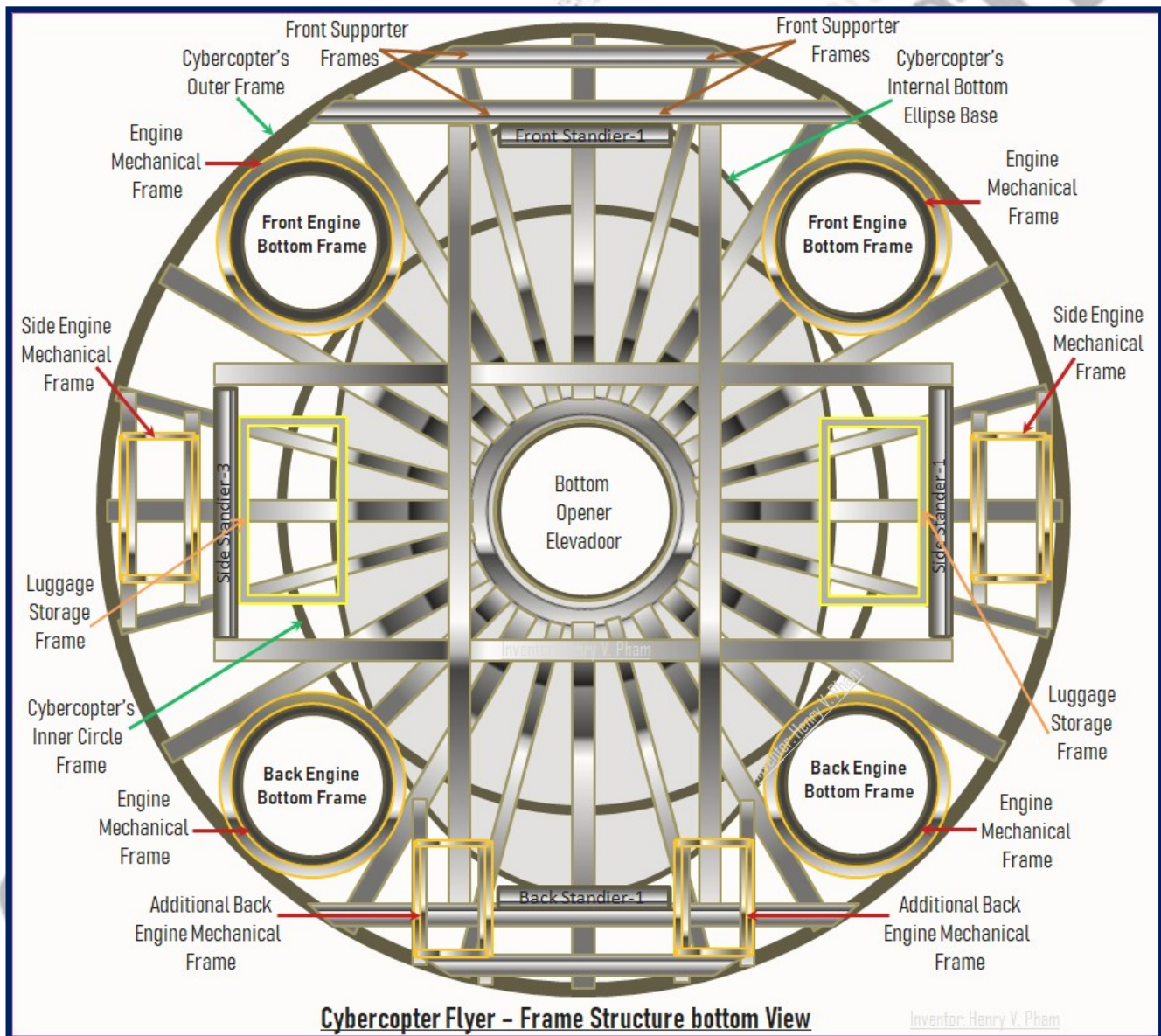

Figure-E7: Cybercopter Flyer – Frame Structure (Bottom view)

Cybercopter Flyer

F. Cybercopter Flyer Internal Views

The Cybercopter Flyer is built in circle shape; when choosing the outer shape dimension larger or the outer radius bigger, the inner floor layout would have more spaces than any other shapes. The Largest Area Shape in the Parallel Transformation Percentage (PTP) Theorem proved, "The e-chord shape with all n sides equal is the largest shape compares to other shapes with the same number of n chord lines that are not equal in a circle, and the shape with more e-chord lines has larger area"; this means circle has greatest area compares to any other shapes with the same circumference. The below **Figure-F1. Cybercopter Flyer - Frame Structure & Inner Floor Layout (Top view)** shows frame structure and the inner floor layout sample of a recommended common flyer size.

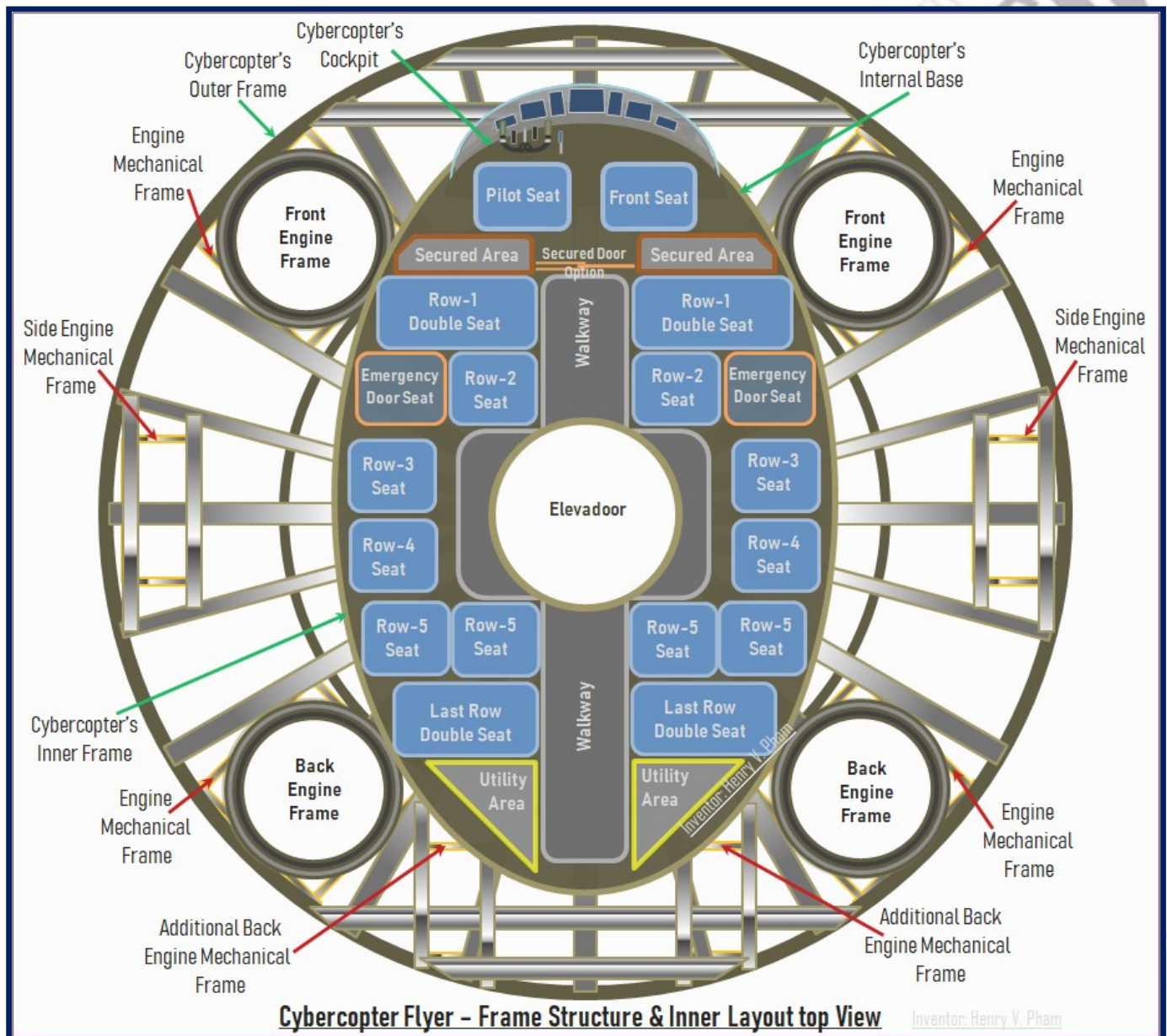

Figure-F1: Cybercopter Flyer - Frame Structure & Inner Floor Layout (Top view)

Cybercopter Flyer

The Cybercopter Flyer cockpit is shown on top of the drawing with pilot seat and one front seat and the dashboard within the secured area with secured door which is recommended for regular flyer sizes with passengers; the cockpit will be shown more detail in later sections. The passenger seats are layout in rows, and the number of rows seats are depended on the dimension of the Cybercopter Flyer. The flyer is recommended to build with Emergency Exit Doors and is required to have for larger flyer with passengers for air transportation services; the Emergency Door Seats are shown on both sides which are close to the Emergency Exit Doors as shown in **Figure-C1: Cybercopter Flyer – Side view** in earlier sections. The utility areas can be used for restrooms, disposal storages or other utility purposes. The Elevadoor is shown at the center and should have enough space around for passengers to access to or from the elevadoor; the elevadoor would come with different options and will be shown more detail in later sections; and again more exits stairs can be built around the elevadoor with foldable stairs like the traditional stairs in existing airplanes.

The Cybercopter Flyer can be built smaller for personal use which can be for one or two persons as shown in the sample layout of the below **Figure-F2: Cybercopter Flyer Personal Version– Frame Structure & Inner Layout**. The **Personal Cybercopter Flyer** would be used for hobby, for personal exploring around the farm, and for other personal activities in the countryside areas as high demand for the human world today for personal use with safer and easier flying compare to the helicopters or any other vertical takeoff airplanes.

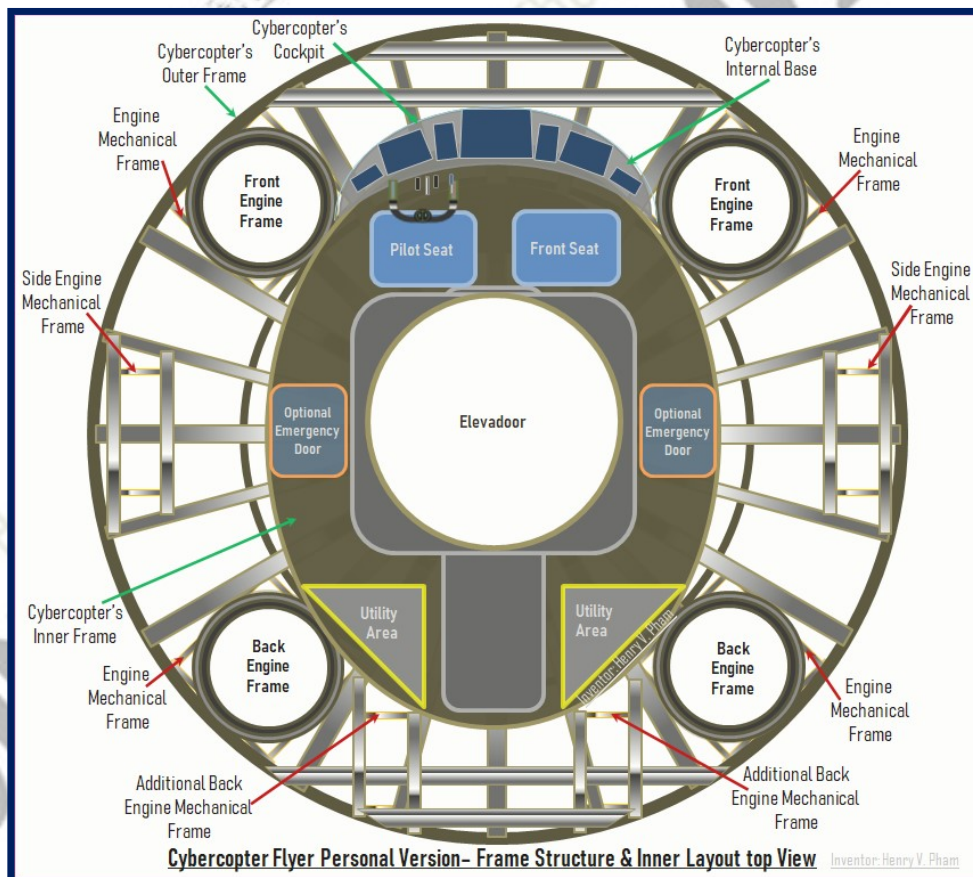

Figure-F2: Cybercopter Flyer Personal Version– Frame Structure & Inner Layout

Cybercopter Flyer

The Cybercopter Flyer is invented and designed with State-of-the-Art and Behavior Consistency which provide the pilot having the same common behaviors as they used to when driving a car and the natural reflexes for human, not like the existing helicopters, aircrafts or any other airplanes. The Cybercopter Flyer cockpit is shown more detail in the below **Figure-F3: Cybercopter Flyer - Cockpit with Controller Dashboard**.

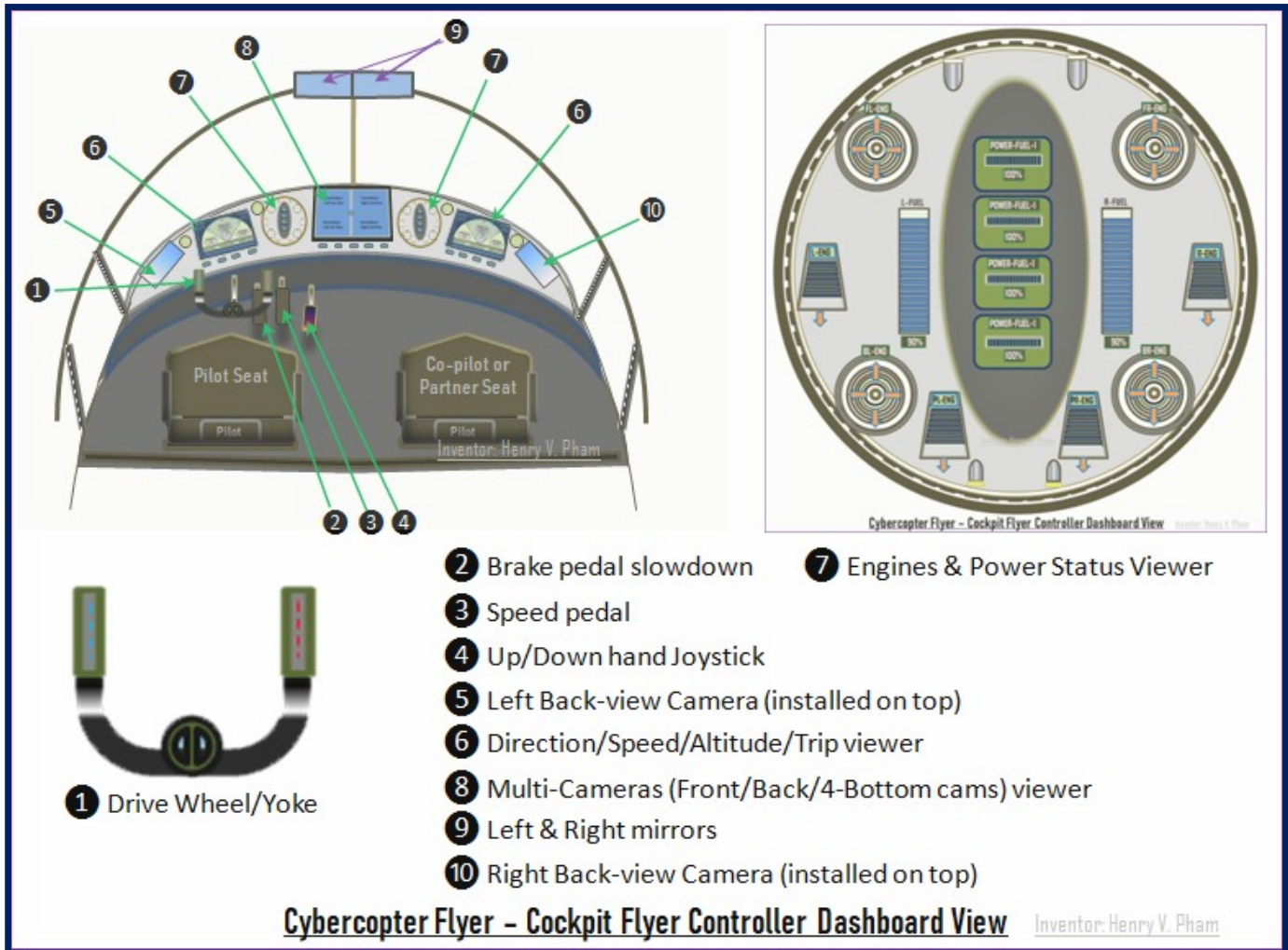

Figure-F3: Cybercopter Flyer - Cockpit with Controller Dashboard

The Drive Wheel/Yoke is used like the steering wheel to control the flyer turning left or right; when the pilot uses the yoke turning left, the control system would reduce the thrust or power of the left side turning engine and increase the thrust or power to the right side turning engine as needed to make a left turn as short as the pilot turning the yoke; when the pilot uses the yoke turning right, the control system would reduce the thrust or power of the right side turning engine and increase the thrust or power to the left side turning engine as needed to make a right turn as short as the pilot turning the yoke. Note that the yoke can have more control buttons to control the switches of dashboard views, entertainment control features, air conditioners, and other functions. The Brake Pedal is used like the car brake pedal to slow down or stop the flyer for hovering; when the pilot pushing on Brake Pedal, the control system would reduce the thrust or set lowest power to all the side pushing and back pushing engines plus

Cybercopter Flyer

controlling the vertical thruster tilting in revert direction as needed to slow down or stop the flyer as hard as the pilot pushing on the brake pedal. The Speed Pedal is used like the car gas pedal to accelerate the flyer to fly faster; when the pilot pushing on the Speed Pedal, the control system would increase the thrust or set lowest power to all the side pushing and back pushing engines plus the vertical thruster tilting more in forward direction as needed to fly as fast as the pilot pushing harder on the Speed Pedal. Note that when the Cybercopter Flyer is parked or still on the ground, the Speed Pedal function should be disabled until the up/down Joystick is pushed to up positions and the flyer is takeoff to a safe altitude; and at low altitude not safe to fly with the standier unfolded, the Speed Pedal should also be disabled until the up/down Joystick is pushed to up positions and the flyer is up to a safe altitude; and the flyer should be equipped with altitude sensor along with the speed tracker. The up/down Joystick is used for first function takeoff to lift the flyer up and last function landing to lower the flyer, and to control the altitude of the flyer during normal flying. Note that the up/down Joystick would have multi-level of lifting higher and lower; safe landing is important and critical for vertical takeoff flyer, the up/down Joystick control system should check for the altitude of the flyer and keep the flyer up or down in safe speed rate in altitude; when the flyer is hovering and in landing mode at low altitude, the Joystick control system should automatically set to lower to lowest speed rate when the flyer get closer to the ground for safer landing. The Cybercopter Flyer is recommended with Left and Right Back Cameras viewers (labeled #5 and #10 on the drawing), like car side mirrors, and the cameras would be installed on top of the flyer to view the top surface engines and for other purposes as shown in [Figure-B1: Cybercopter Flyer - Top view](#). The Cybercopter Flyer is also recommended with Left and Right Back Mirrors (labeled #9 on the drawing), like car back mirror, the left back mirror is set for the pilot view and the right back mirror is set for the co-pilot or the front partner if the flyer has front partner seat.

The Cybercopter Flyer is recommended to use Quadletter Compass which was introduced in my other invention "OH SMART AIRPORT"; the Quadletter Compass uses the 4 compass letters, 'N' stands for North, 'S' stands for South, 'E' stands for East and 'W' stands for West of the main directions in the quadrant or the 90° degrees representation. The Quadletter Compass shows main compass letter at the center; the other directions on the left would be between -44° degrees to the main compass letter (0°), and directions on the right would be between the main compass letter (0°) to +45° degrees. The below [Figure-F4: Cybercopter Flyer - Quadletter Compass Recommendation for Dashboard #6](#) shows some use cases of the Quadletter Compass. The top left drawing shows the car heading (right) North at +15° degrees; the top right drawing shows the car heading (left) North at -10° degrees; the bottom left drawing shows the flyer heading (right) North at +25° degrees; and the bottom right drawing shows the flyer heading (left) South at -20° degrees. The Quadletter Compass will change the main compass direction letter with one of the followings 'N', 'S', 'E', and 'W' when the vehicle heading within the quadrant of the main compass direction where the main compass direction is at the middle. The Direction/Speed/Altitude/Trips viewer (labeled #6 on the drawing above) is recommended to build with standard counters and use the new Quadletter Compass for the Cybercopter Flyer dashboard. The Cybercopter Flyer dashboard is recommended to layout in symmetry of geometry on both sides for better Look-and-Feel when the flyer has a co-pilot or a front partner seat.

Cybercopter Flyer

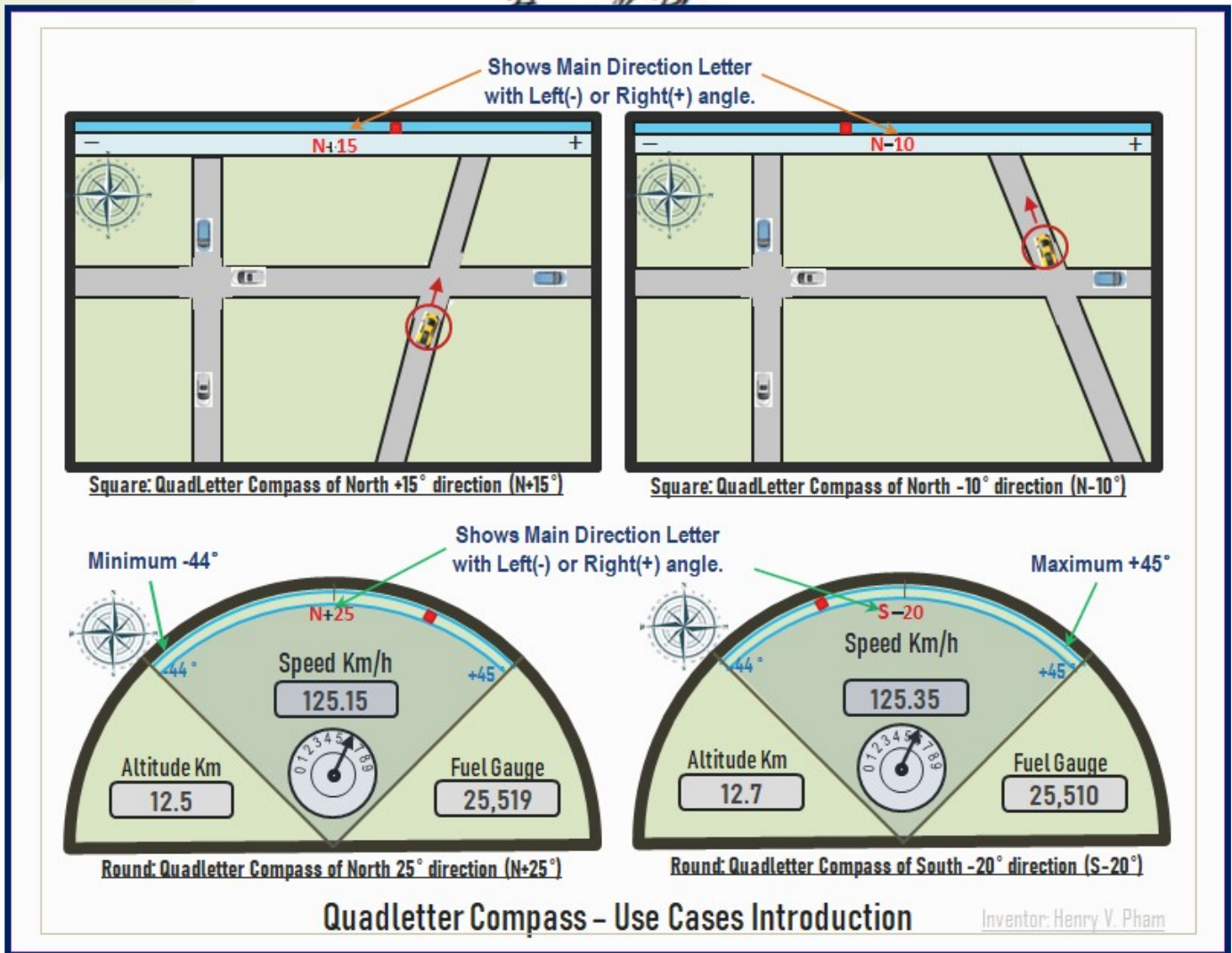

Figure-F4: Cybercopter Flyer - Quadletter Compass Recommendation for Dashboard #6

The below **Figure-F5: Cybercopter Flyer - Balance Coordinate & Diometers for Dashboard #6** shows the flyer Balance Coordinate and Diometers sample on the dashboard as labeled #6. The Balance Coordinate shows the flyer balance for left 'L' and right 'R' in +/- degrees on the side labels, and also shows the balance bar with 2 dots on the side; when the flyer is tilting within the tolerances, then the balance bar shows within the orange rectangle; when the flyer is tilting out of the tolerances, then the balance bar shows with angle in slope in degrees outside of the orange rectangle. The Balance Coordinate would also show the tilting angle of head and tail of the flyer in the same way as left and right balance but in the other orange rectangle showing vertically; however, the head and tail balance would be shown down on left side and up on the right side of the orange vertical rectangle. The Diometers at the bottom shows the Quadletter Compass, Speed Diometer, Altitude Diometer, Fuel Gauge, Inside and Outside Temperature, and the clock time and the trip timing at the bottom. The Cybercopter Flyer is also recommended with lifetime statistic and counters like the total flying time, total numbers of takeoff and landing, and other useful info as needed to compare the data at a later time with other flyers to check for the reliability.

Cybercopter Flyer

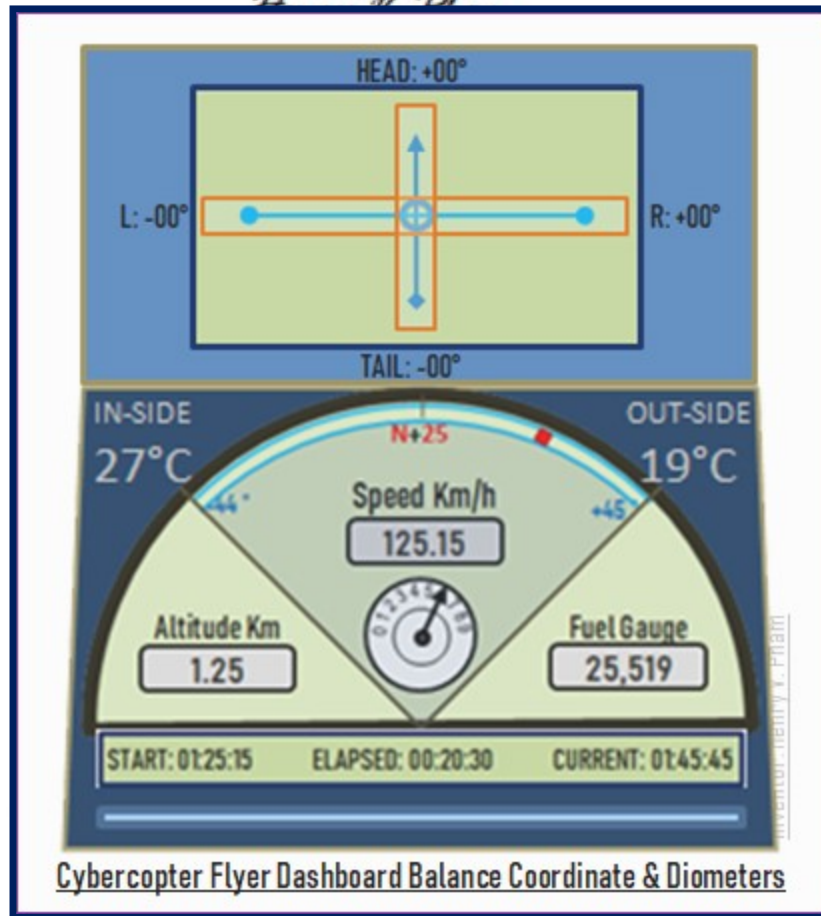

Figure-F5: Cybercopter Flyer – Balance Coordinate & Diometers for Dashboard #6

The flyer dashboard layout is important to show as much indicators and diometer for statistic counters as possible and as simplified and organized as possible to give the pilot with the clear views and checking alerts and diometer counters quickly and easily. The below **Figure-F6: Cybercopter Flyer -Engine Dashboard Indicators Dashboard #7 view** shows the Engine Power, Fuel, Light indicators. The middle section shows the Power/Fuel life indicators of the main 4 vertical thrust engines and plus other solar powers packs as needed. The Left Fuel and Right Fuel indicators are used to show the fuel life of the side fuel tanks on both sides of the flyer if the flyer comes with it. The thrust Direction/Power status indicators of the 4 main vertical engines are shown in circle, which can be used to indicate the power spinning of the turbofan or turbojet engines in more circle lines for more power and less circle lines for less power of spinning plus the direction of the thruster tilter in the orange arrows; if the flyer Thruster Tilter is built with the Square Thruster Tilter, then the arrows come with 4 directions; if the flyer Thruster Tilter is built with Hexagon Thruster Tilter, then the arrows come with 6 directions. There are different Thruster Tilters which are shown in more detail in later sections. The side Pushing/Turning Engines on both sides of the flyer and the back Pushing Engines are also recommended to have power/status indicators as shown in the drawing to provide the pilot the status and the current performance of the engines. And of course the head and tail lights are also important to show the status indicators to notify the pilot if a light is out.

Cybercopter Flyer

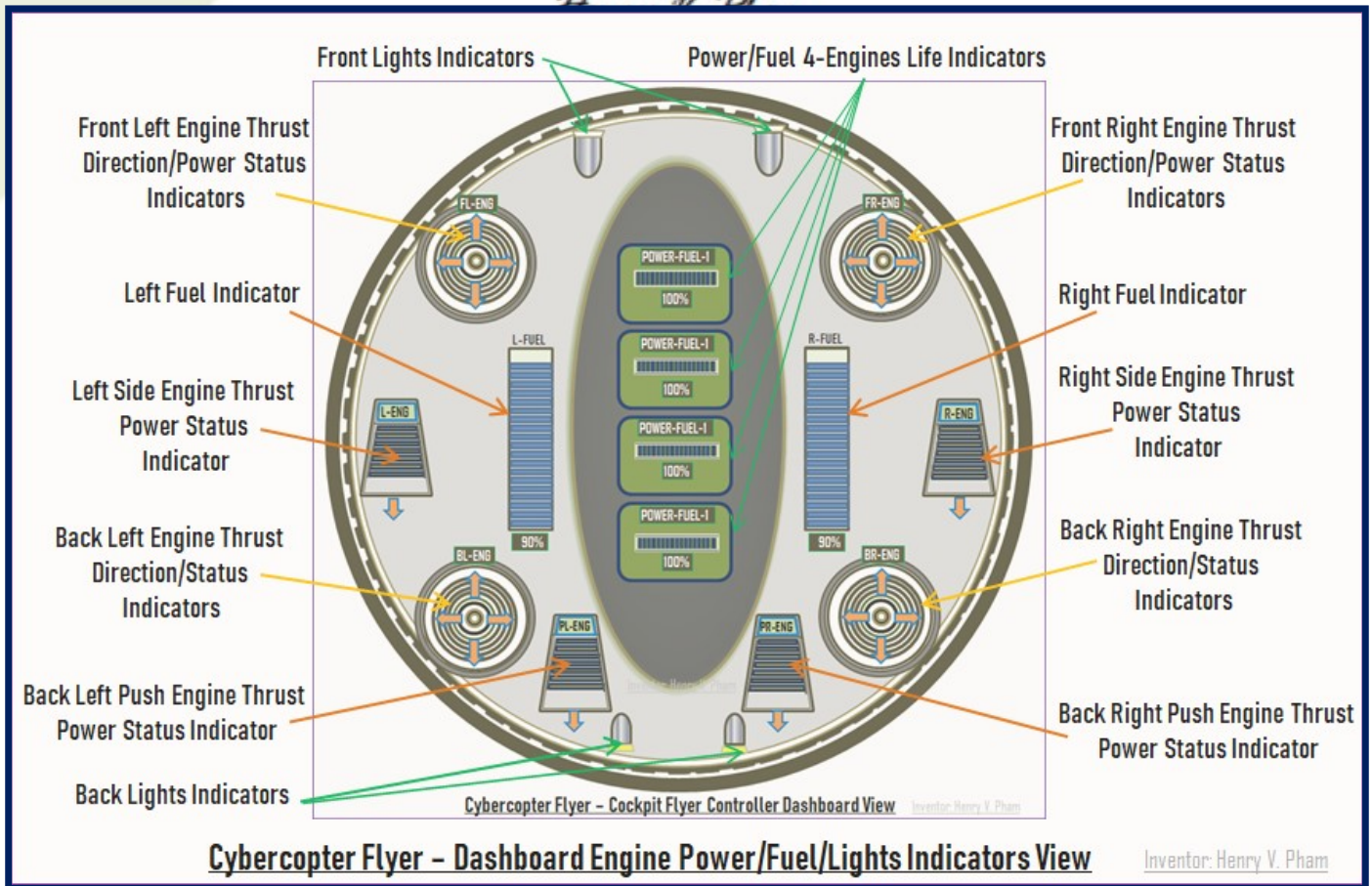

Figure-F6: Cybercopter Flyer -Engine Dashboard Indicators Dashboard #7 view

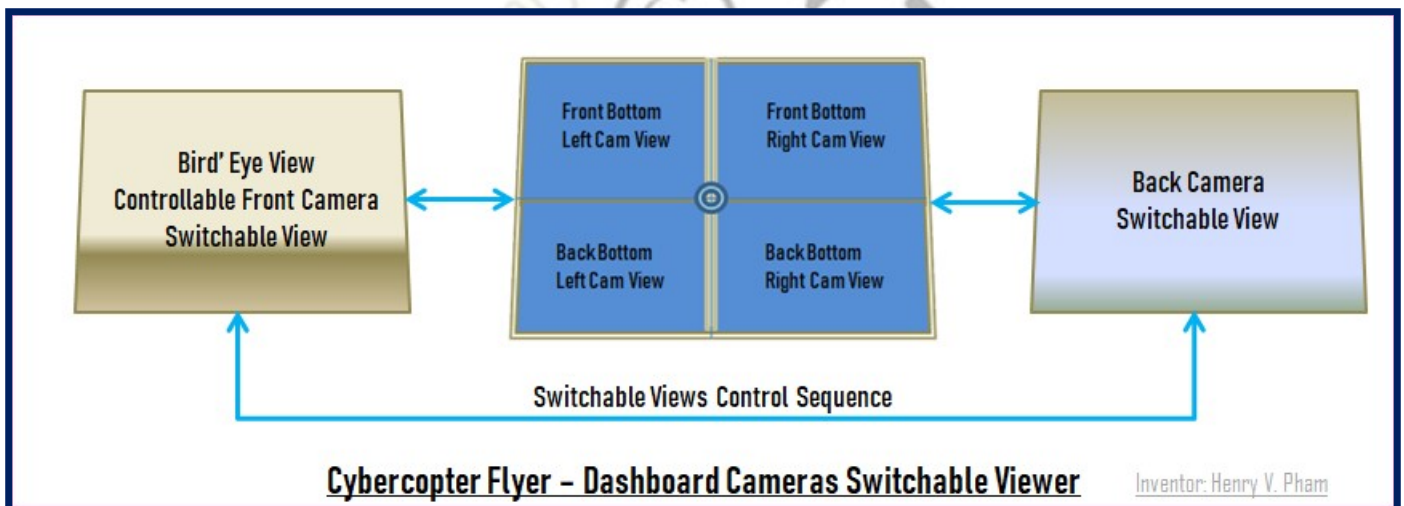

Figure-F7: Cybercopter Flyer - Dashboard Cameras Switchable Viewer Dashboard #8

The Cybercopter Flyer would come with one bird eye view camera in front, one on the back, and 4 cameras to view bottom of the 4 main vertical thrust engines as mentioned in the previous section and shown in [Figure-D1: Cybercopter Flyer - Bottom view](#). The above [Figure-F7: Cybercopter Flyer - Dashboard Cameras Switchable Viewer Dashboard #8](#) shows the main screen at the center of the dashboard which can be switchable views which is cycling between the front zoom-able and controllable camera with the 4 bottom corner engines

Cybercopter Flyer

viewing cameras and with the back (tail) camera as shown in light blue arrows in figure above. Note that the 2 side-cameras on top of the flyer are always viewable on the sides of the cockpit like the car side mirrors. The camera switchable view function buttons can be built on the yoke with a switching button and also can be built on the dashboard right below the camera viewers as the standard dashboard for existing vehicles. The power button and other security buttons and other standard features are not showing detail in the drawing; however, the Cybercopter Flyer should be equipped with secured key to fly to prevent stealing or hijacking the flyer.

G. Cybercopter Flying Modes

The Cybercopter flying modes are showing in this section with many different views, normal flying mode in front view, normal flying mode in side view, and flying with left and right turning. The below **Figure-G1: Cybercopter Flyer – Normal Flying mode (Front view)** shows the front view in normal flying mode. The engines thrusters of the 4 main vertical engines are shown in vertically right under the flyer in front view; the front view in normal flying mode shows 2 head lights and recommended with at least 3 LED lights on each side to indicate the front of the Cybercopter Flyer.

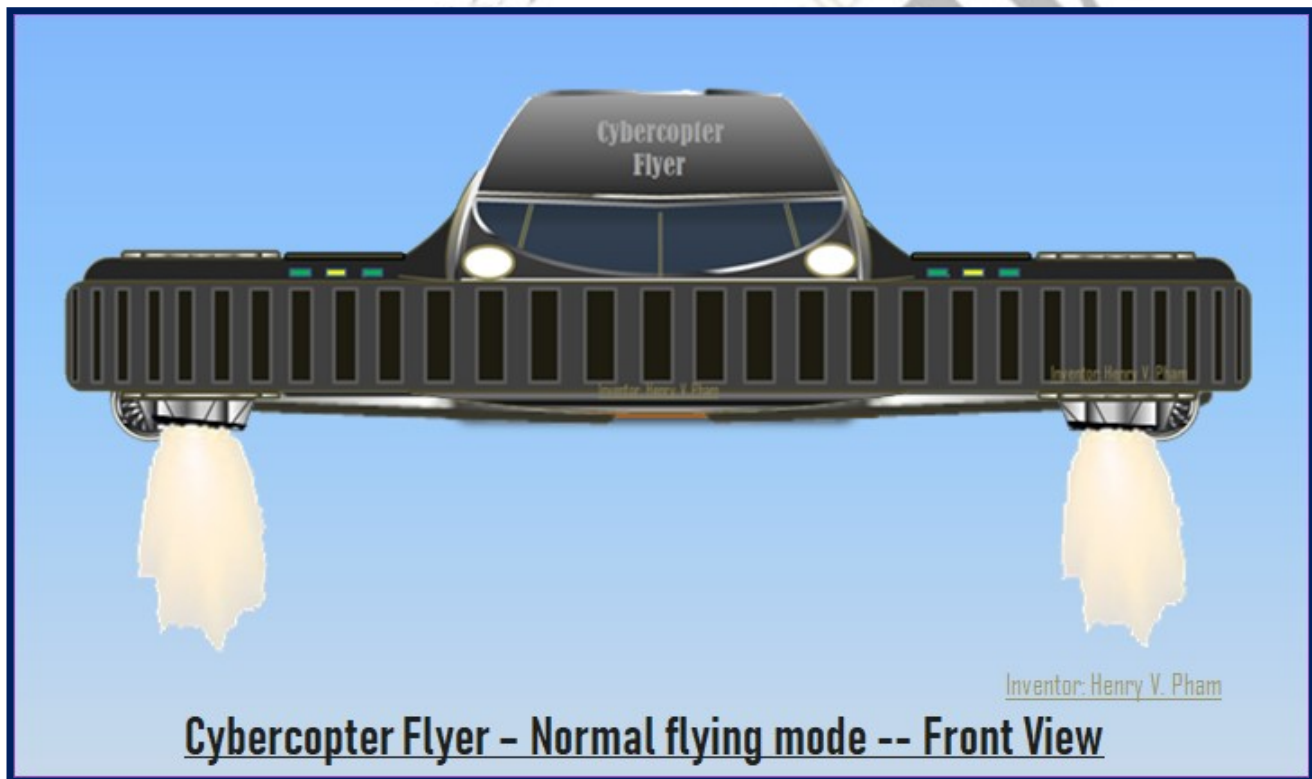

Figure-G1: Cybercopter Flyer – Normal Flying mode (Front view)

The **Figure-G2: Cybercopter Flyer – Fast Flying mode (Side view)** below shows the Cybercopter Flyer flying in fast mode which all full power of the side pushing engines and back pushing engines, plus the 4 main vertical engines showing in forward direction which make the flyer flying faster. The Engine Thruster Tilters can tilt the thrust to a certain angle which is depend on the space available and the Thruster Tilter types; the Engine Thruster Tilters are shown detail in later sections. When the pilot pushes on the brake pedal during flying, the Engine Thruster Tilters of the 4 main vertical engines push the thrusts in revert angle to make

Cybercopter Flyer

the flyer slow down to stop depends on how hard the pilot pushing on the brake pedal as shown in **Figure-G3: Cybercopter Flyer - Slowing/Stopping mode (Side view)** below. Note that when the pilot pushes on the brake pedal, the side pushing engines and the back pushing engines should be reduced the power to reduce the thrusts pushing the flyer forward besides reducing power of the 4 main vertical thrust engines.

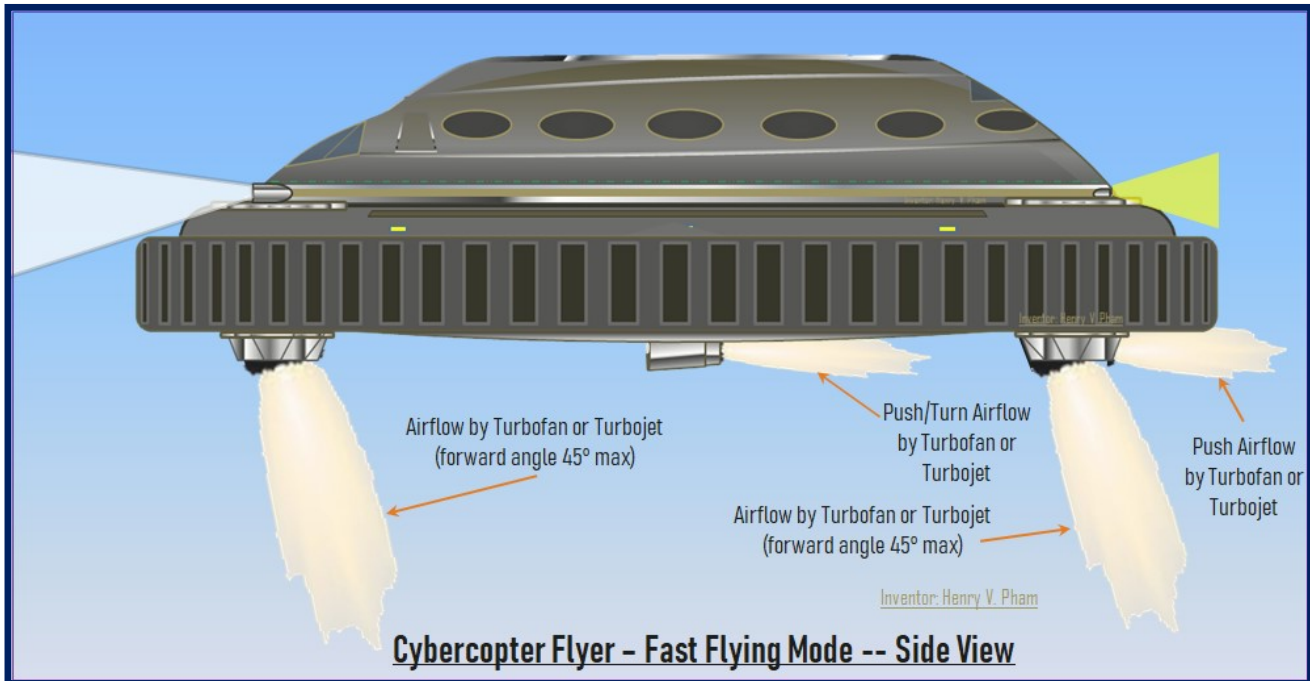

Figure-G2: Cybercopter Flyer - Fast Flying mode (Side view)

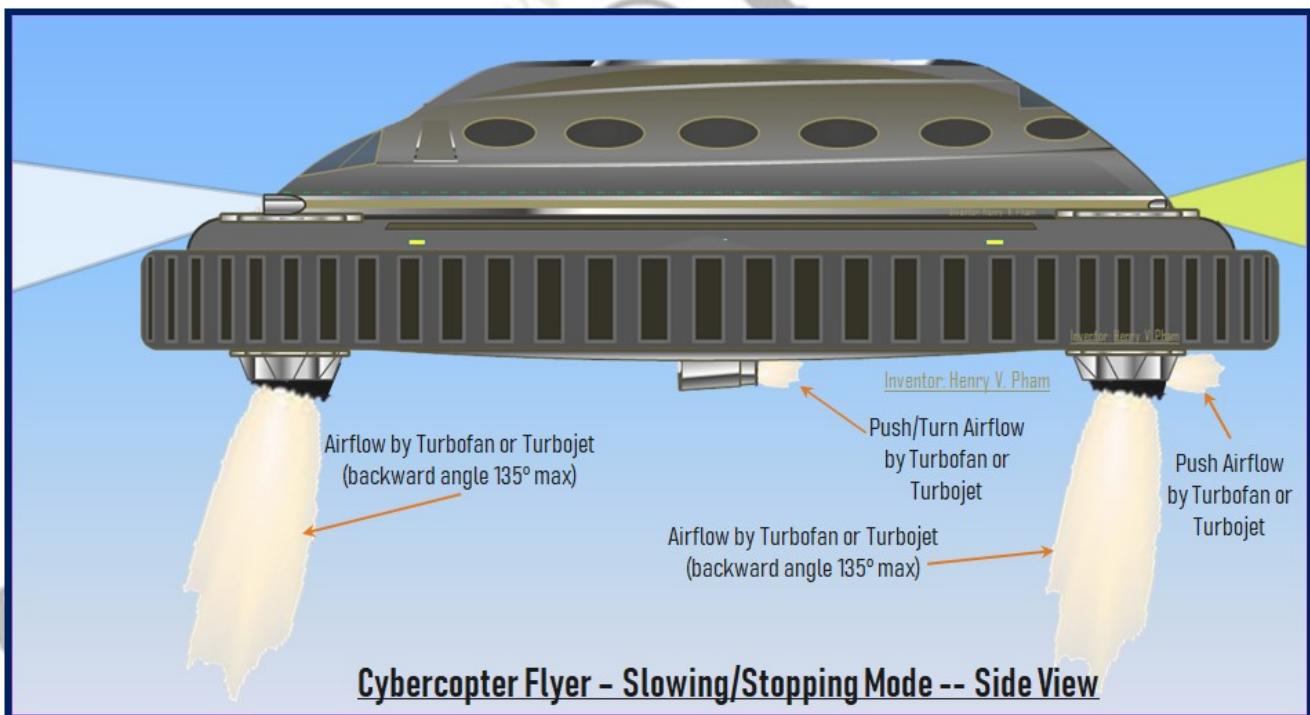

Figure-G3: Cybercopter Flyer - Slowing/Stopping mode (Side view)

Cybercopter Flyer

When the pilot turns the yoke to the left side, the flyer system would reduce power of the left pushing engine and increase power of the right pushing engines if needed to make a left turn as quick as how hard the pilot turning the yoke to the left side. The below **Figure-G4: Cybercopter Flyer - Left Turn Flying mode (Top view)** shows the Cybercopter Flyer makes a left turn with less power for the left engine thrust, and keep the same power for the right engine thrust in this case in this drawing. However, the pilot can push on the brake pedal while making a turn; this case the turning side pushing engine and back pushing engines are reduced in power plus the 4 main vertical thrust engines tilting in revert angle to provide the quicker turn.

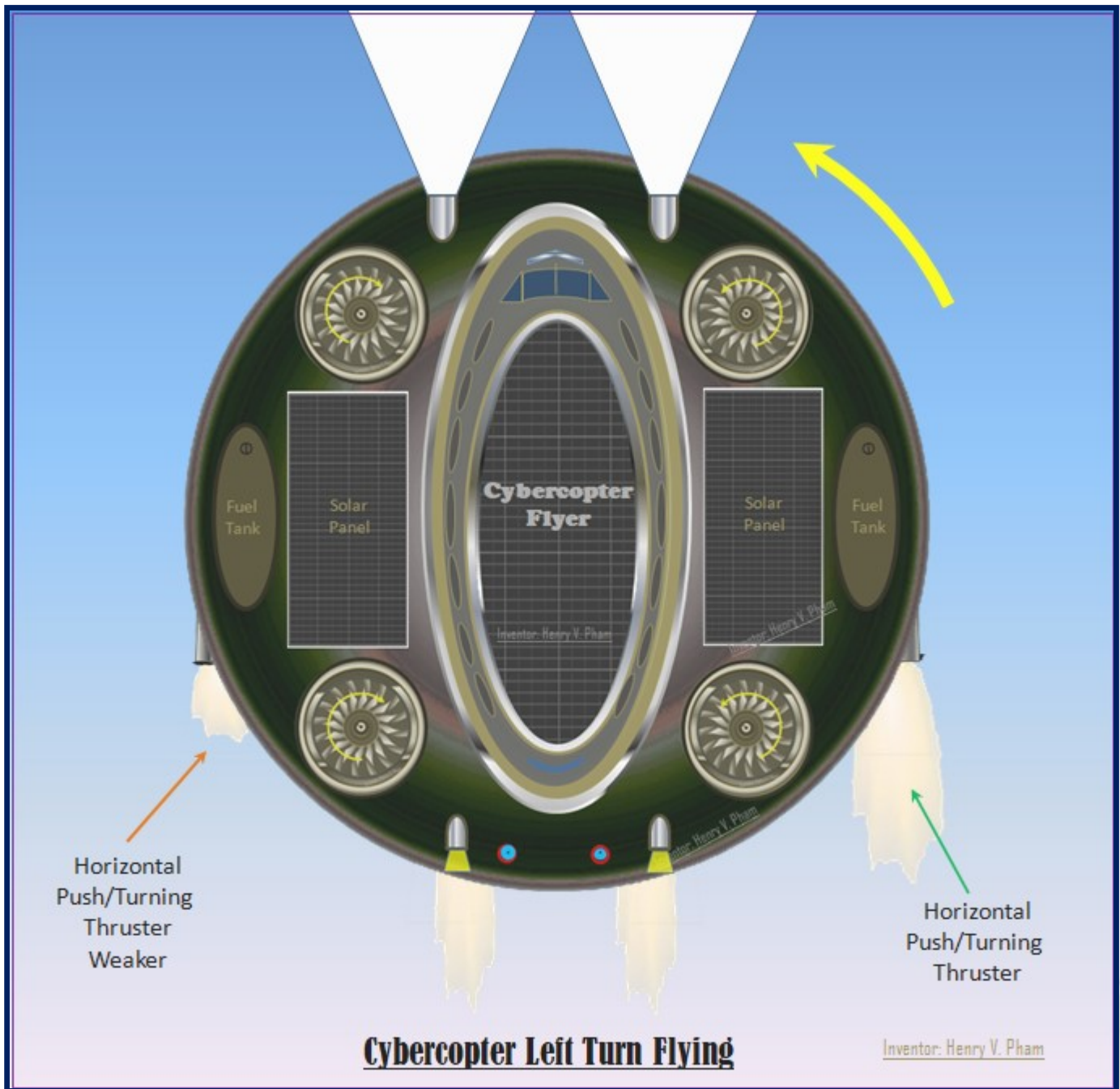

Figure-G4: Cybercopter Flyer - Left Turn Flying mode (Top view)

Cybercopter Flyer

- Similar to the left turn above when the pilot turns the yoke to the right, the flyer system would reduce power of the right pushing engine and increase power of the left pushing engines if needed to make a right turn as quick as how hard the pilot turning the yoke to the right side. The below **Figure-G5: Cybercopter Flyer - Right Turn Flying mode (Top view)** show the Cybercopter Flyer making a right turn during flying.

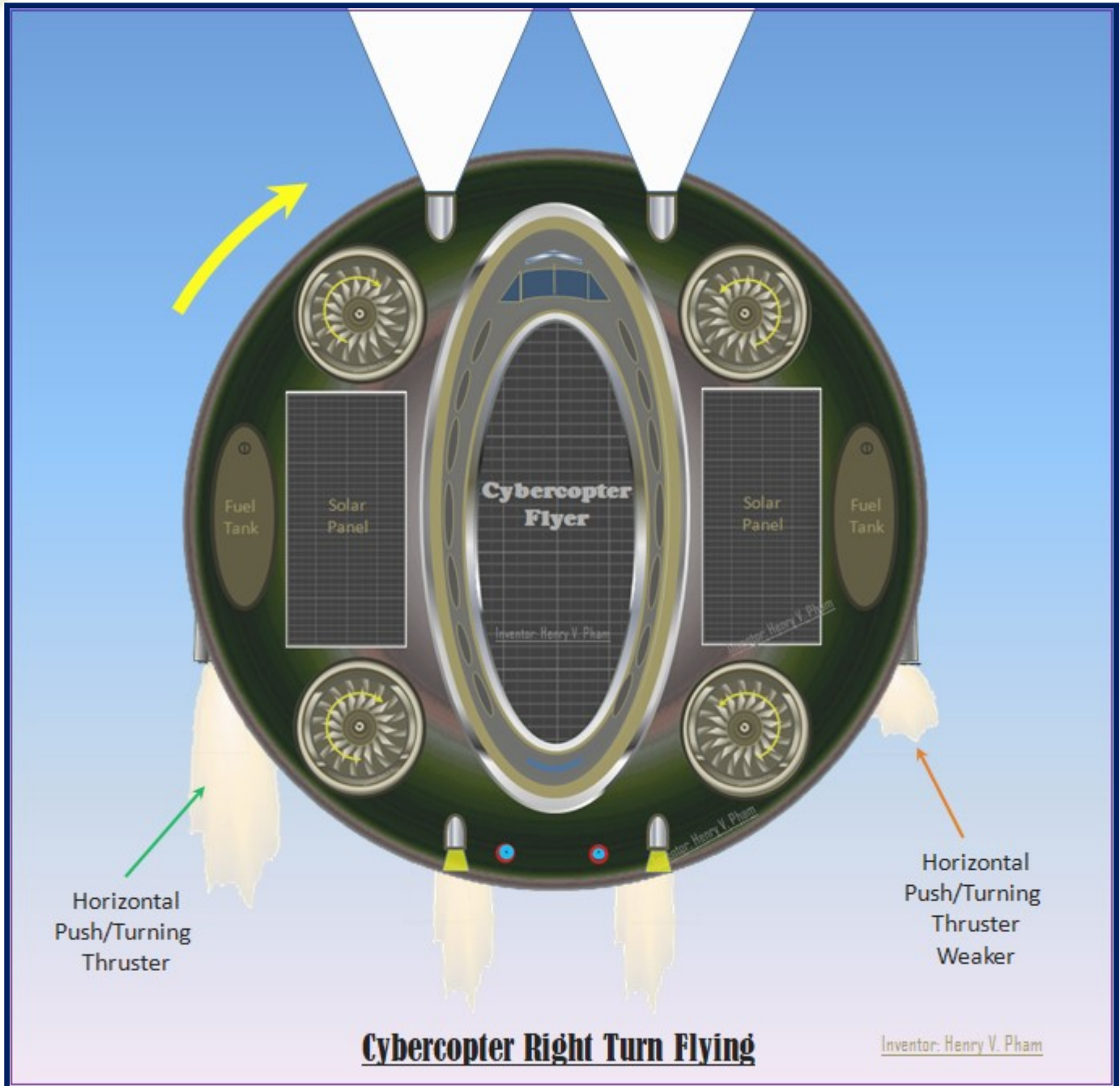

Figure-G5: Cybercopter Flyer - Right Turn Flying mode (Top view)

Cybercopter Flyer

The Cybercopter Flyer can come with the large Elevadoor which can be opened and used during fly for sightseeing or sky diving while the passengers or the freefall team seating on the foldable stair-seat-ring as shown in the below **Figure-G6: Cybercopter Flyer – Flying mode with Sightseeing or Sky diving Stairs Elevadoor**. The stair-seat-ring Elevadoor is foldable by the center pole and the 4 poles around the elevadoor base; note that when folded the elevadoor, all the stair-seats would be flatten on the same floor; the foldable rail option can be added holding while ready for sky diving and recommended for military versions. The Elevadoor comes with different options and will be shown more details in later sections.

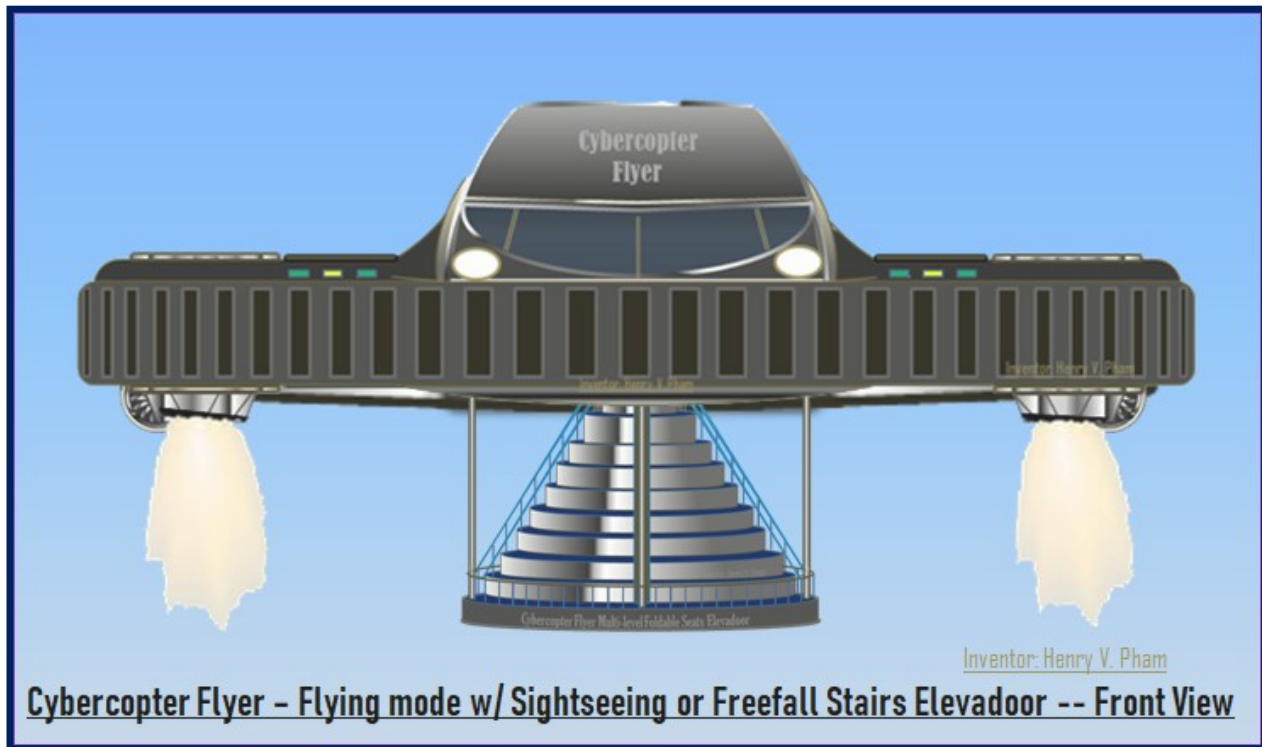

Figure-G6: Cybercopter Flyer – Flying mode with Sightseeing or Sky diving Stairs Elevadoor

H. Cybercopter Flyer Landing & Unfolding Standier Front Views

The standier is important and critical for the vertical takeoff and landing for any flyer; the Cybercopter Flyer would come with the safe standier with recommendation of at least 1.5 meter tall as shown detail in later section that provides the Cybercopter Flyer with safer landing with foldable standier. This section will show the Cybercopter Flyer from flying mode view to other views of landing of the standier. The below **Figure-H1: Cybercopter Flyer – Landing with Unfolding Standier Position 1 (Front view)** shows the Cybercopter Flyer prepares for landing with standier at the position-1. The flyer is expected hovering above the ground and prepared for landing with the standier is started releasing from the flyer's body at position-1, then the standier unfolded to position-2 as shown in **Figure-H2: Cybercopter Flyer – Landing with Unfolding Standier Position 2 (Front view)**. At the first position, the foot of the standier kicks off from the flyer body to start unfolding, at the same time the motors on the legs of the standiers would turn the legs to unfold; note that the foot is shown with orange border. **Figure-H3: Cybercopter Flyer – Landing with Unfolding Standier Position 3 (Front view)** below shows the standier unfolded to position-3 with more foot and leg showing. The standier

Cybercopter Flyer

supporter shows vertical in 90° degrees angle at position-4 as shown in **Figure-H4: Cybercopter Flyer - Landing with Unfolding Standier Position 4 (Front view)**. Follow the procedure of unfolding, the Cybercopter Flyer standier is unfolded fully from position-1 to position-8 as shown in the following next figures from **Figure-H5** to **Figure-H8**.

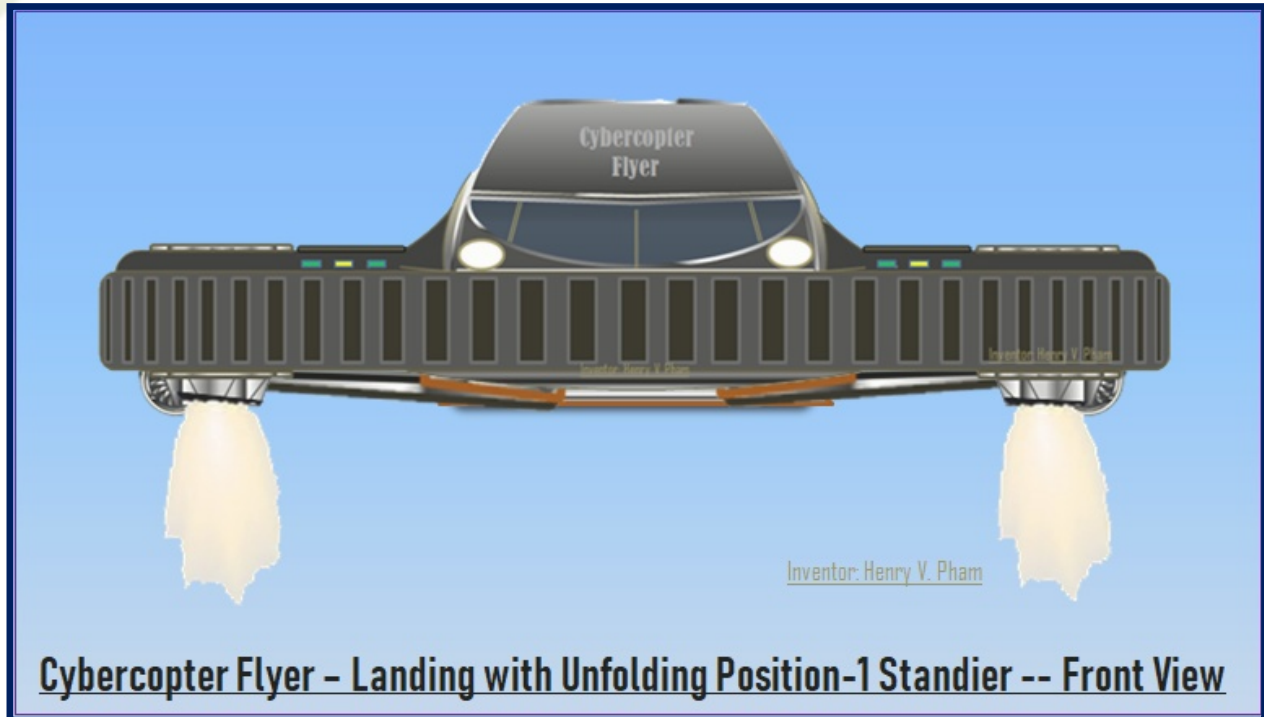

Figure-H1: Cybercopter Flyer - Landing with Unfolding Standier Position 1 (Front view)

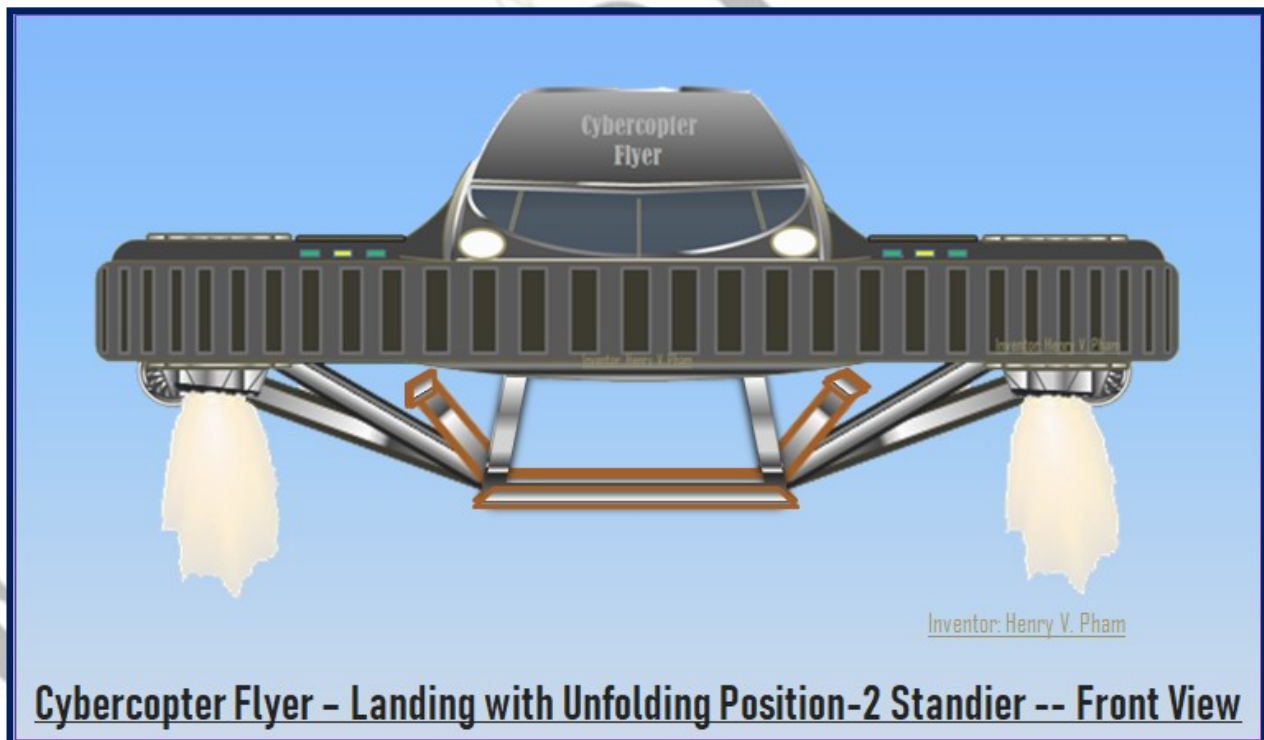

Figure-H2: Cybercopter Flyer - Landing with Unfolding Standier Position 2 (Front view)

Cybercopter Flyer

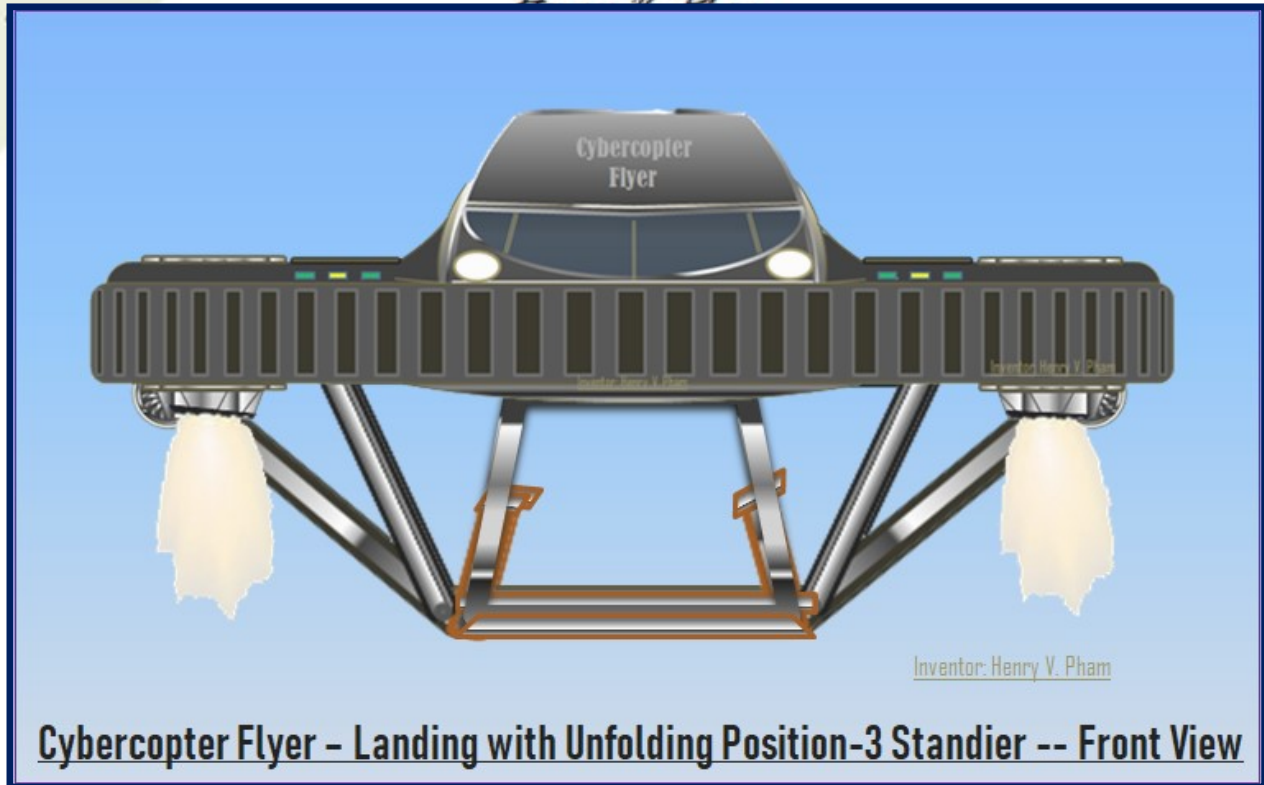

Figure-H3: Cybercopter Flyer – Landing with Unfolding Standier Position 3 (Front view)

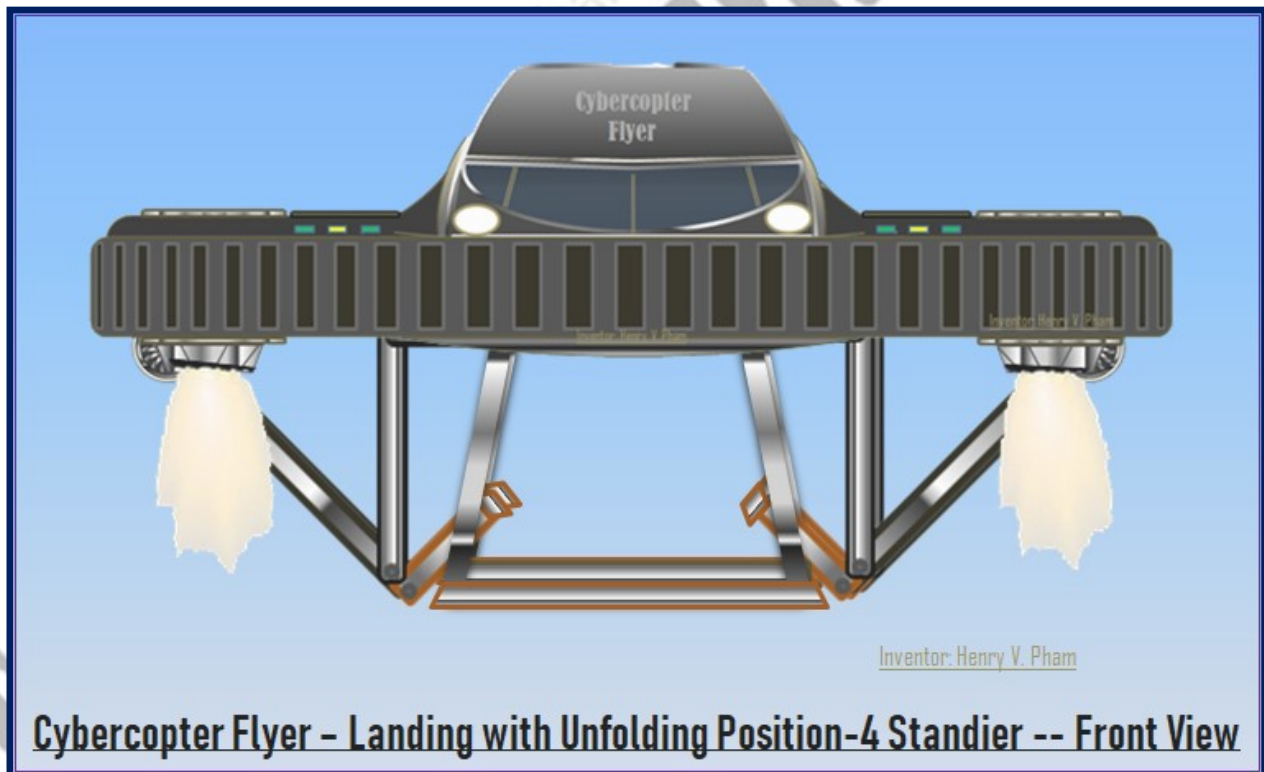

Figure-H4: Cybercopter Flyer – Landing with Unfolding Standier Position 4 (Front view)

Cybercopter Flyer

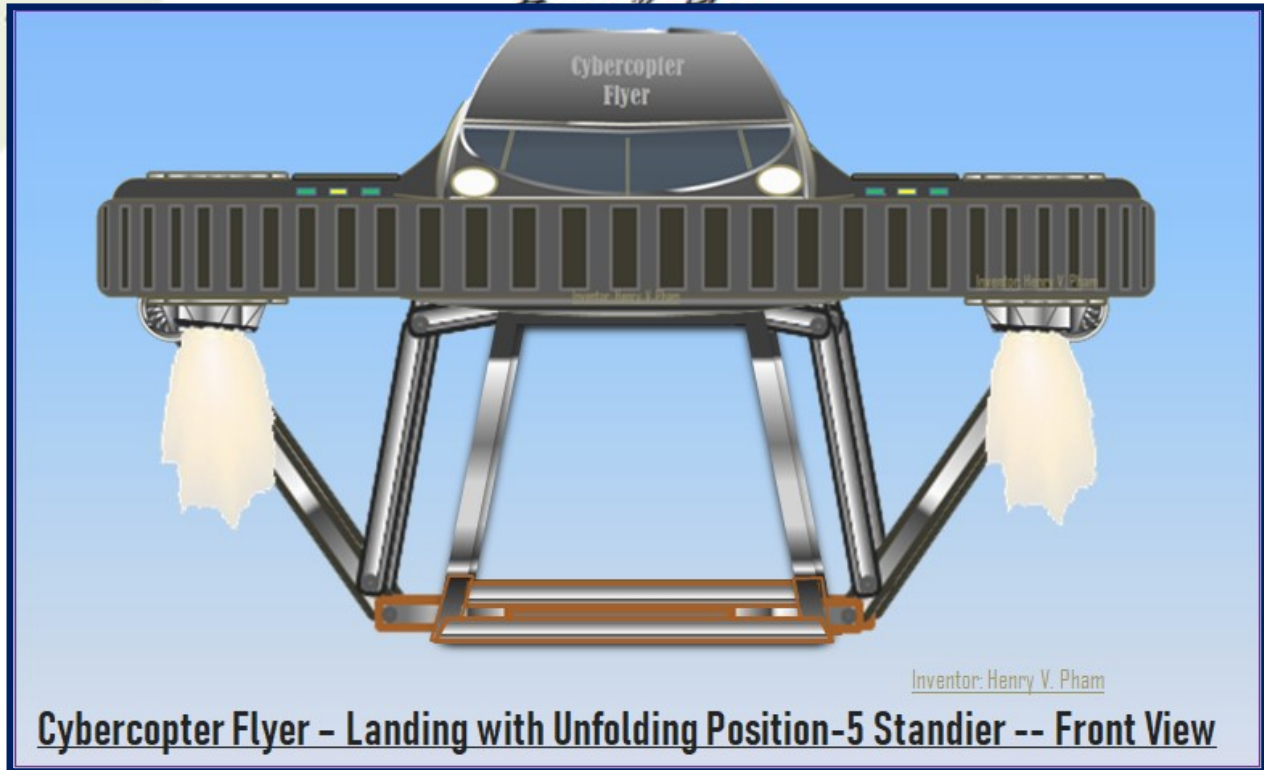

Figure-H5: Cybercopter Flyer - Landing with Unfolding Standier Position 5 (Front view)

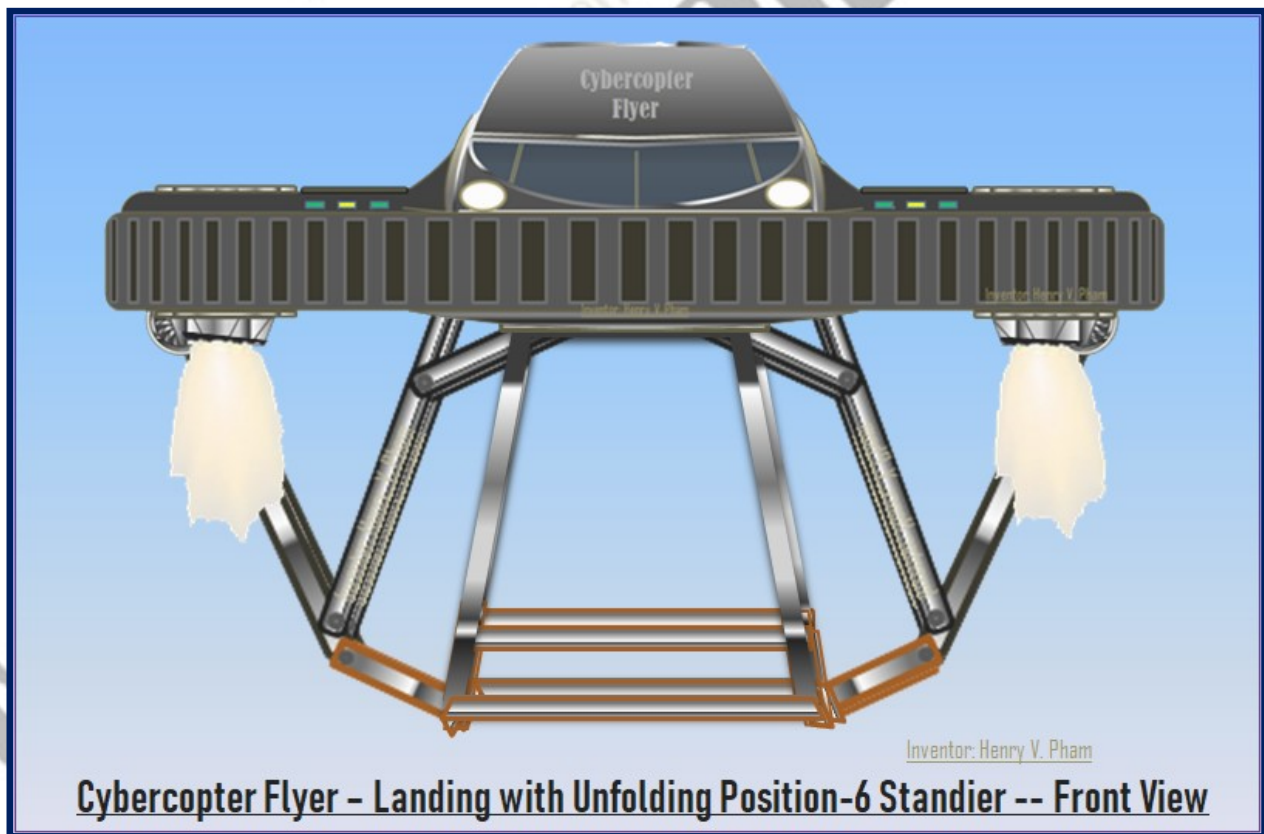
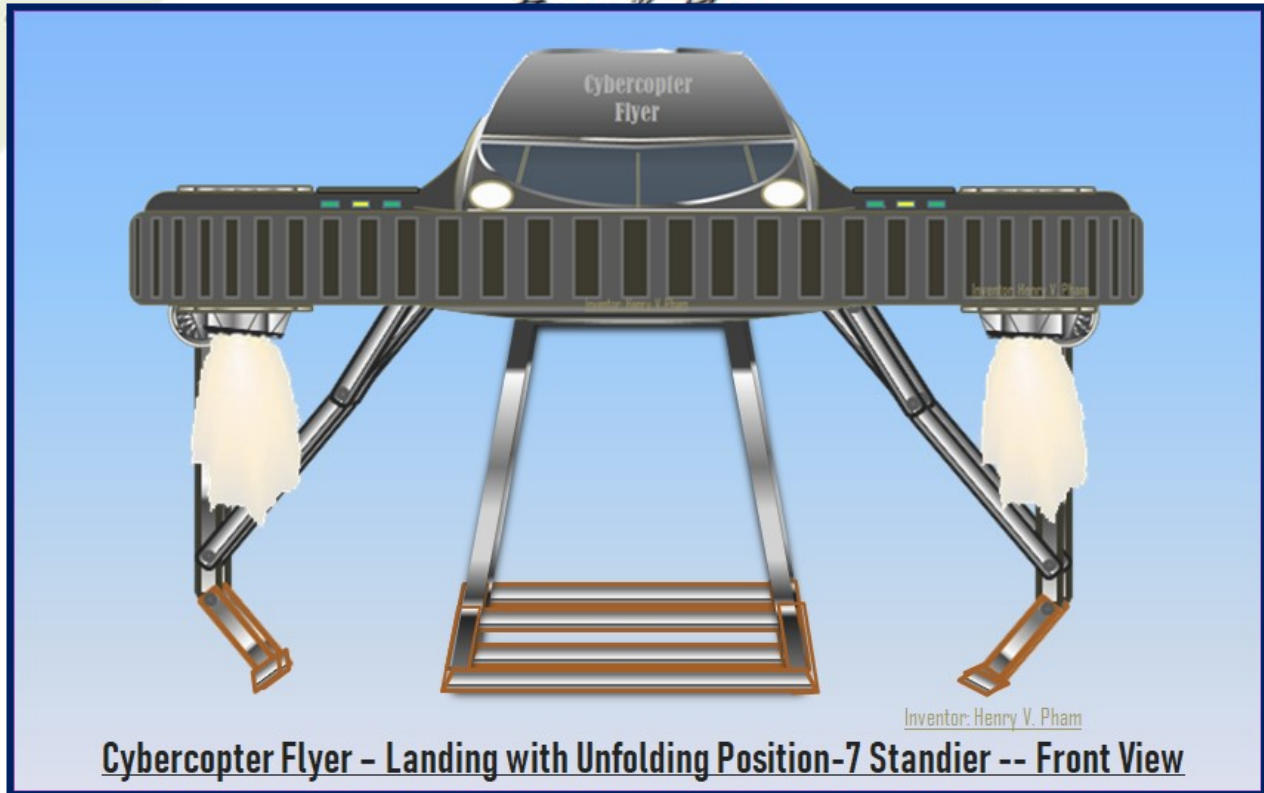

Figure-H6: Cybercopter Flyer - Landing with Unfolding Standier Position 6 (Front view)

Cybercopter Flyer



Cybercopter Flyer - Landing with Unfolding Position-7 Standier -- Front View

Figure-H7: Cybercopter Flyer - Landing with Unfolding Standier Position 7 (Front view)

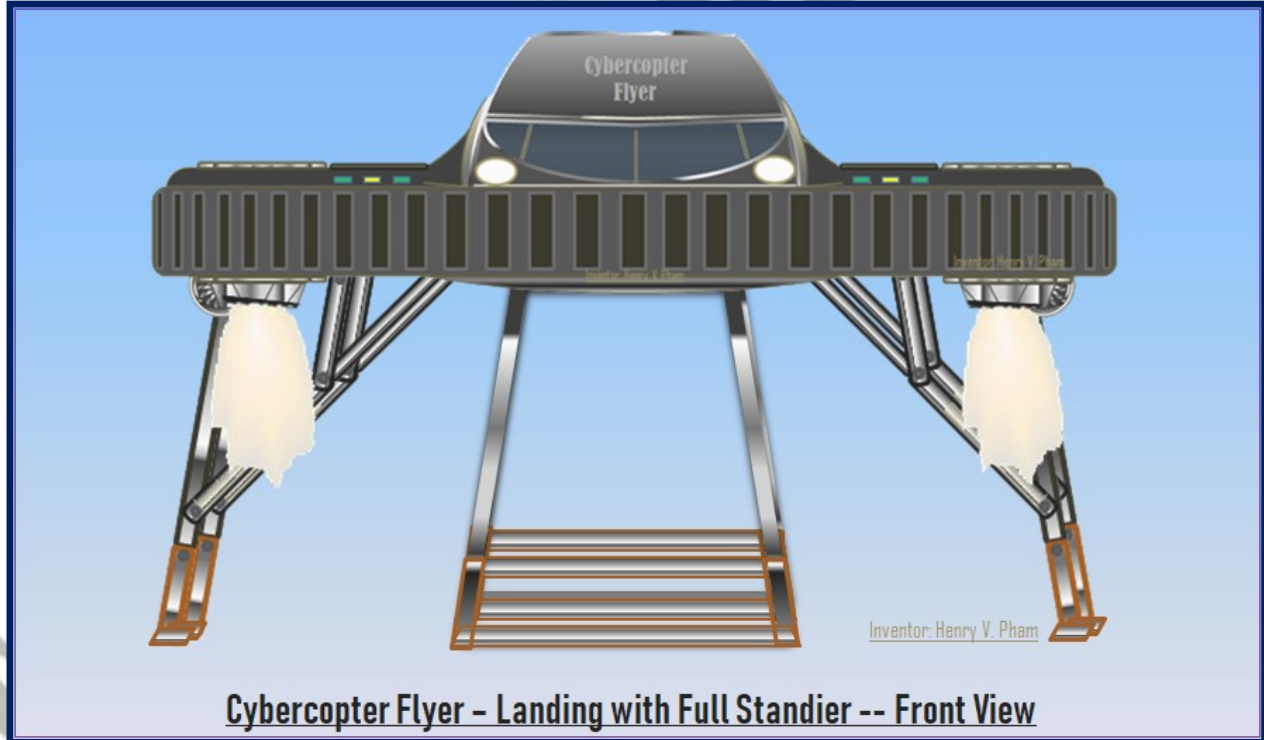

Cybercopter Flyer - Landing with Full Standier -- Front View

Figure-H8: Cybercopter Flyer - Landing with Full Standier (Front view)

The standier is fully unfolded as shown in **Figure-H8: Cybercopter Flyer - Landing with Full Standier (Front view)** above.

Cybercopter Flyer

I. Cybercopter Flyer Parking Mode with Stairs Elevadoor Front Views

When the Cybercopter Flyer standier is completely unfolded and the all engines are off, the elevadoor can be opened for passengers to take off from the flyer.

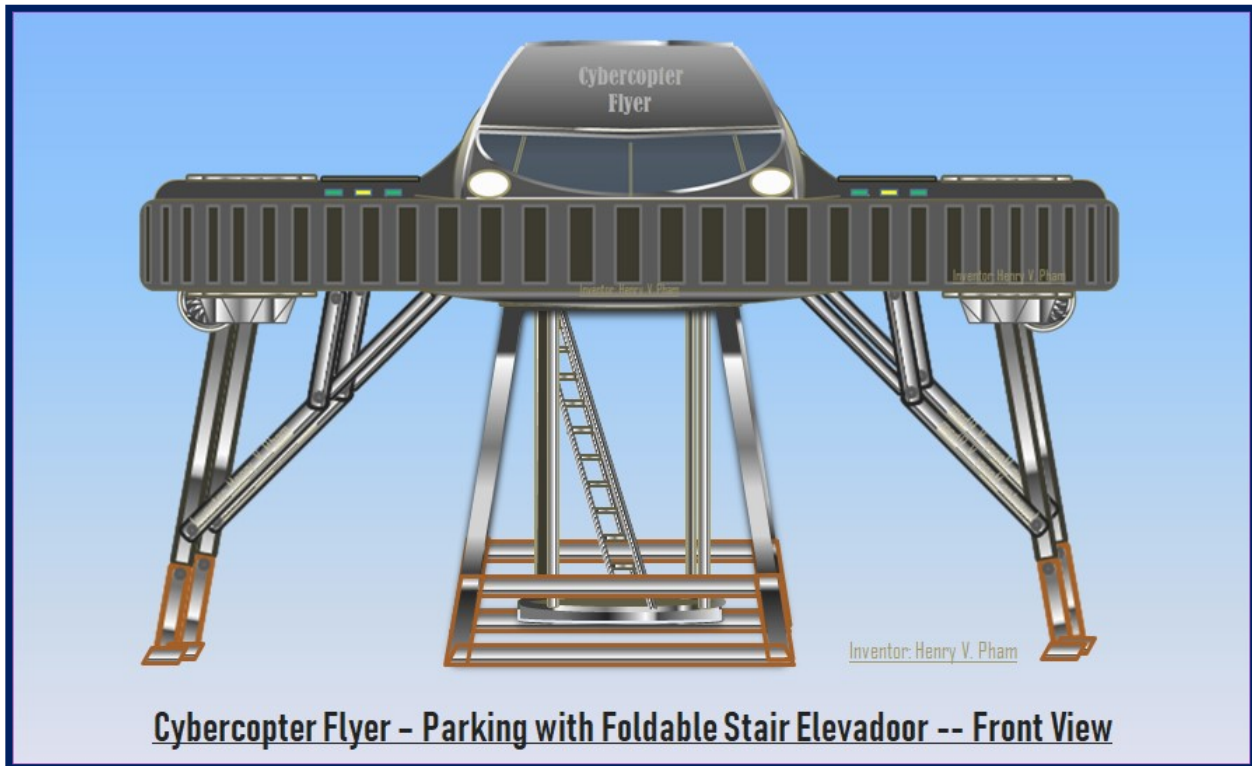

Figure-I1: Cybercopter Flyer - Parking with Foldable Stair Elevadoor (Front view)

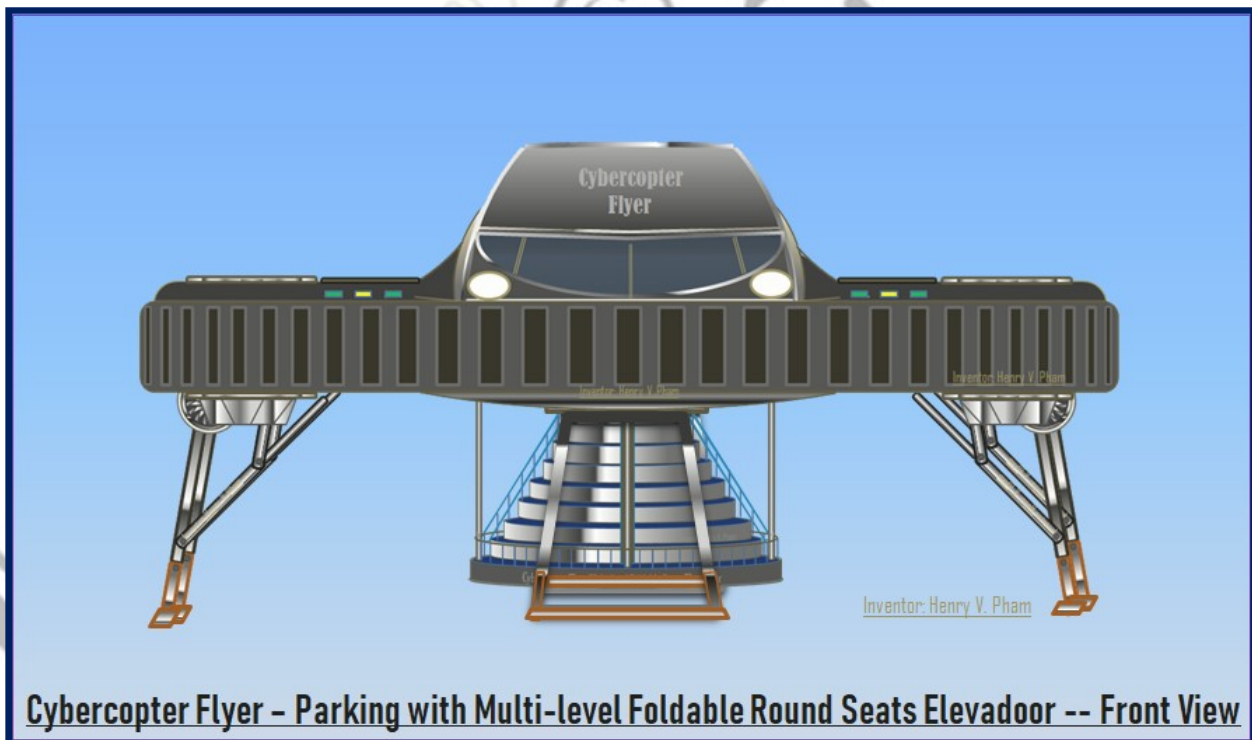

Figure-I2: Cybercopter Flyer - Parking with Multi-Level Foldable Round Seats Elevadoor (Front view)

Cybercopter Flyer

The above Figure-I1: Cybercopter Flyer - Parking with Foldable Stair Elevadoor (Front view) shows the Cybercopter Flyer in front view which is parked with the elevadoor opened with a stair as an option to take off in this drawing. There are more options of the elevadoor that will be shown detail in later sections, in this section the common stair Elevadoor is shown in this figure; and the multi-level foldable stair-seat Elevadoor is shown in Figure-I2: Cybercopter Flyer - Parking with Multi-Level Foldable Round Seats Elevadoor (Front view). The multi-level foldable ring stair-seat Elevadoor which is already mentioned in the previous sections which is introduced for sightseeing and sky diving flyer versions. The Cybercopter Flyer is expected to be a large size and the ring stair-seat in the elevadoor can be used as the stair for the passengers to take off from the flyer.

J. Cybercopter Flyer Landing & Unfolding Standier Side Views

The standier unfolding for landing on side view is similar to the front view as shown in the previous section. Figure-J1: Cybercopter Flyer - Landing with Unfolding Standier Position 1 (Side view) shows the standier starts unfold at position-1. The flyer is expected hovering above the ground and prepared for landing with the standier is started releasing from the flyer's body at position-1, then the standier unfolded to position-2 as shown in Figure-J2: Cybercopter Flyer - Landing with Unfolding Standier Position 2 (Side view). Same as front views at the first position, the foot of the standier kicks off from the flyer body to start unfolding, at the same time the motors on the legs of the standiers would turn the legs to unfold; note that the foot is shown with orange border. Figure-J3: Cybercopter Flyer - Landing with Unfolding Standier Position 3 (Side view) below shows the standier unfolded to position-3 with more foot and leg showing. The standier supporter shows vertically in 90° degrees angle at position-4 as shown in Figure-J4: Cybercopter Flyer - Landing with Unfolding Standier Position 4 (Side view). Follow the procedure of unfolding, the Cybercopter Flyer standier is unfolded fully from position-1 to position-8 as shown in the following next figures from Figure-J5 to Figure-J8.

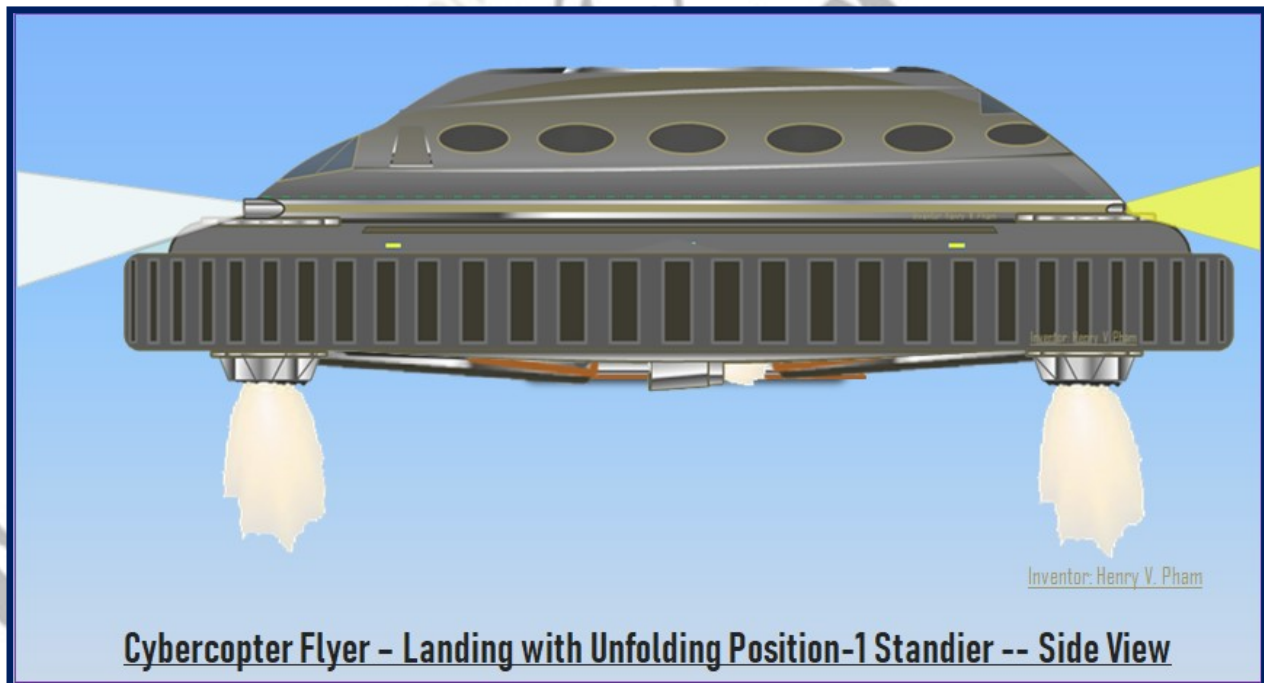

Figure-J1: Cybercopter Flyer - Landing with Unfolding Standier Position 1 (Side view)

Cybercopter Flyer

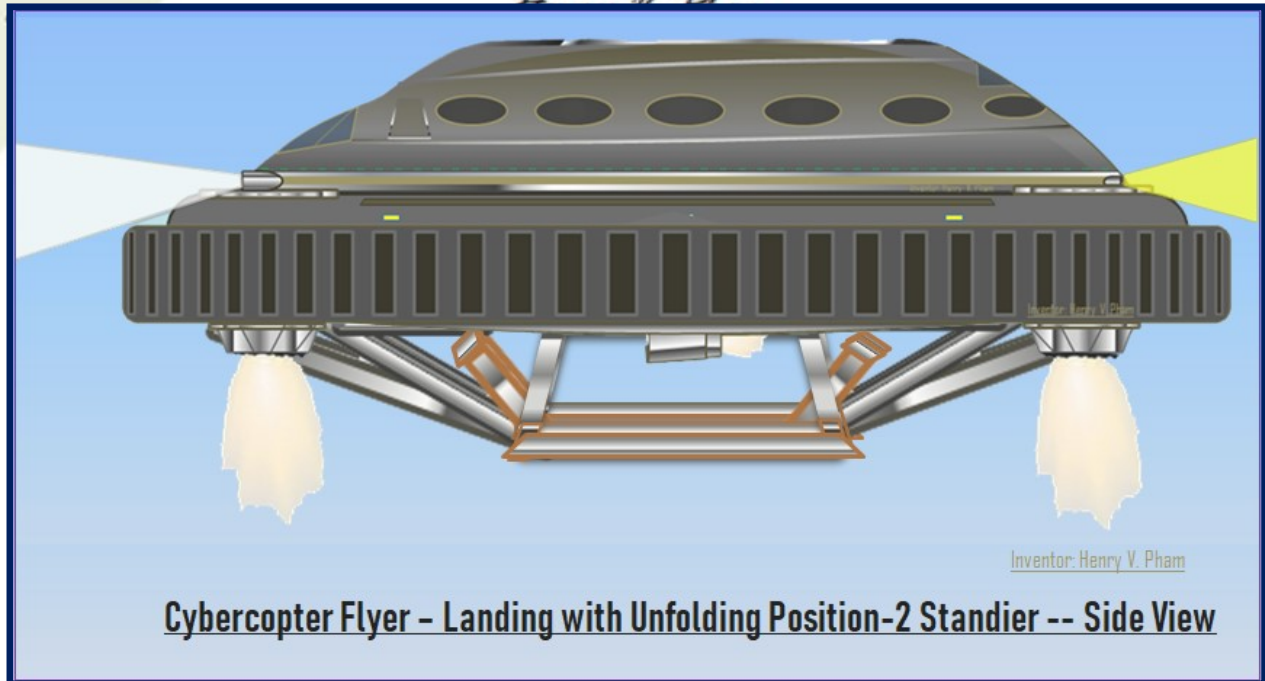

Figure-J2: Cybercopter Flyer - Landing with Unfolding Standier Position 2 (Side view)

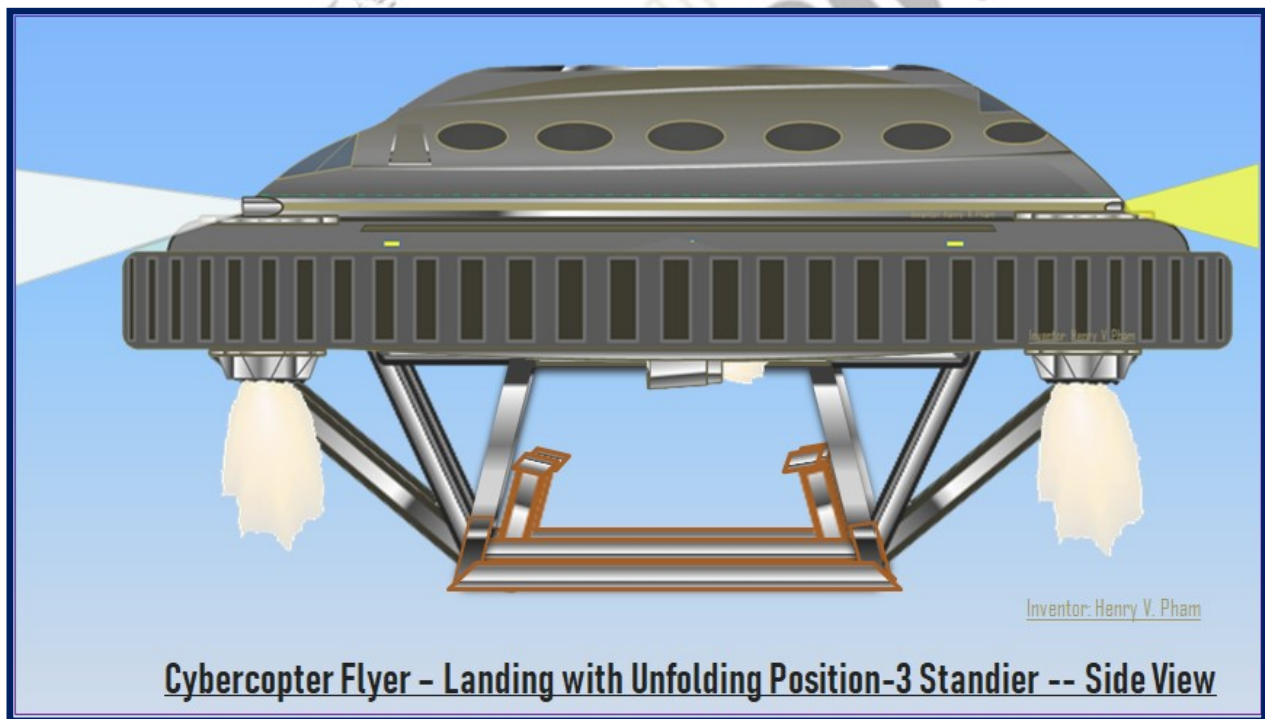

Figure-J3: Cybercopter Flyer - Landing with Unfolding Standier Position 3 (Side view)

Cybercopter Flyer

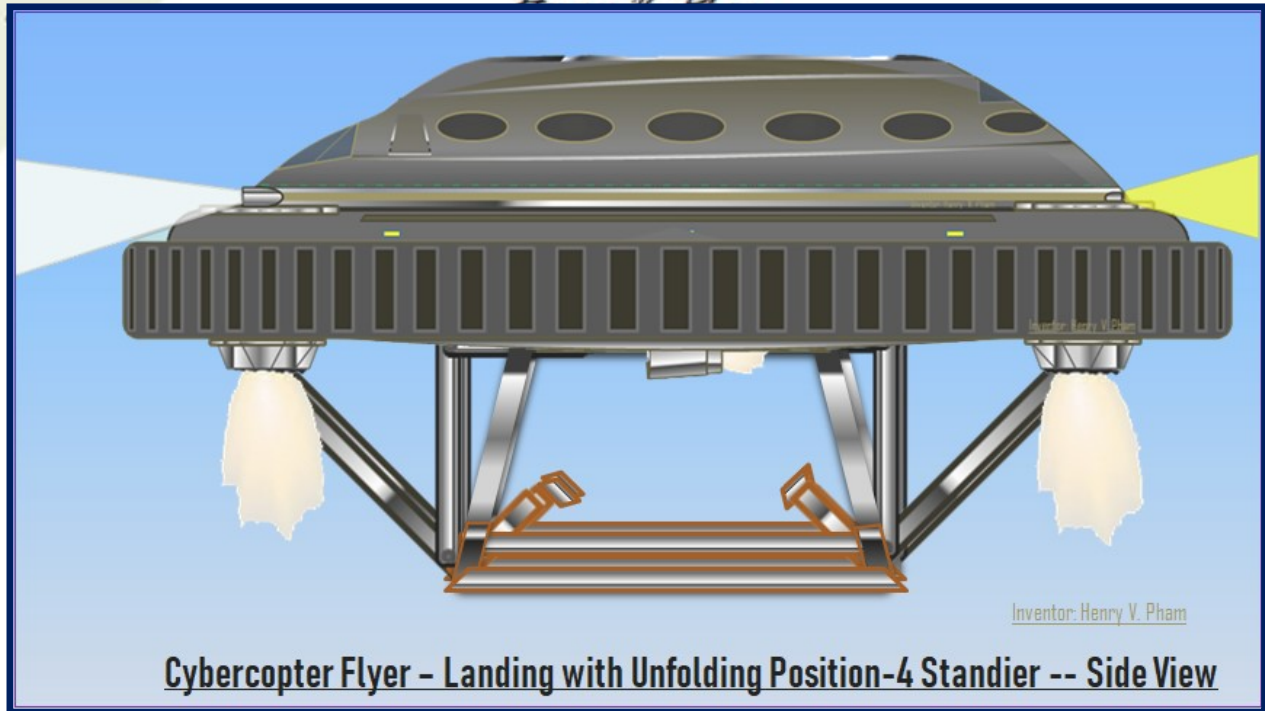

Figure-J4: Cybercopter Flyer - Landing with Unfolding Standier Position 4 (Side view)

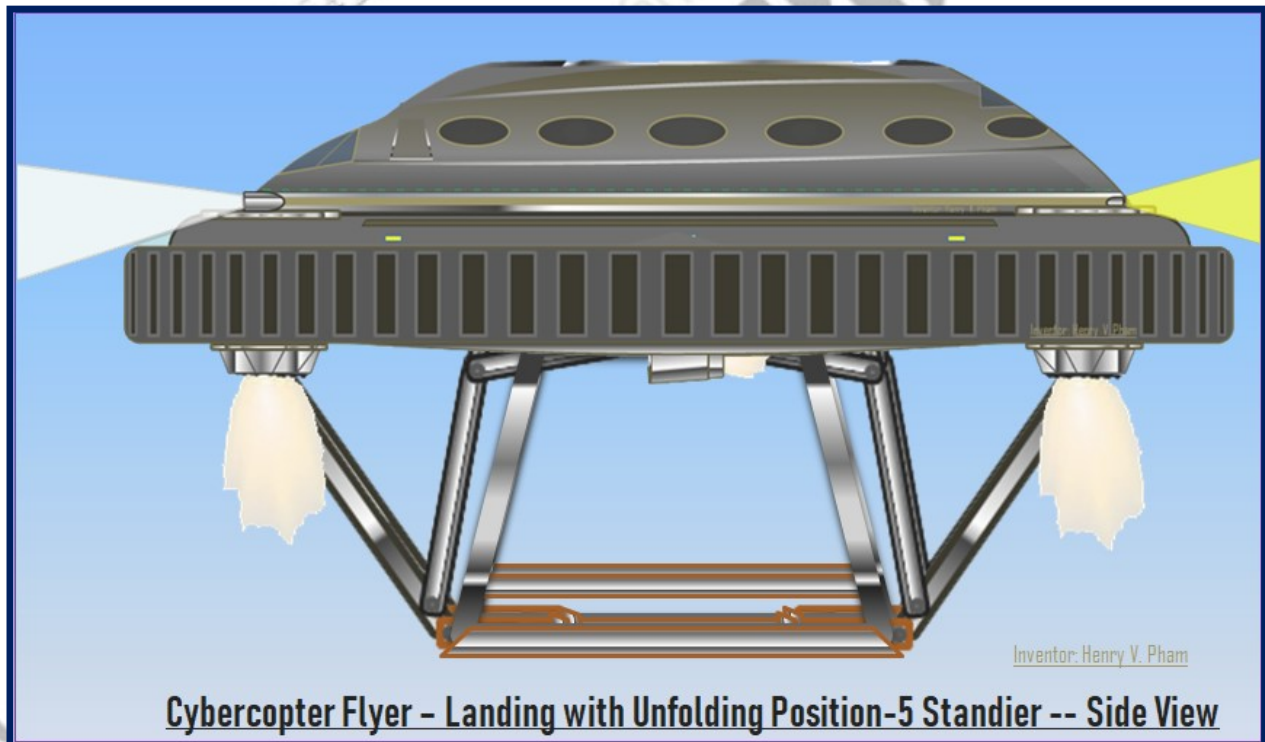

Figure-J5: Cybercopter Flyer - Landing with Unfolding Standier Position 5 (Side view)

Cybercopter Flyer

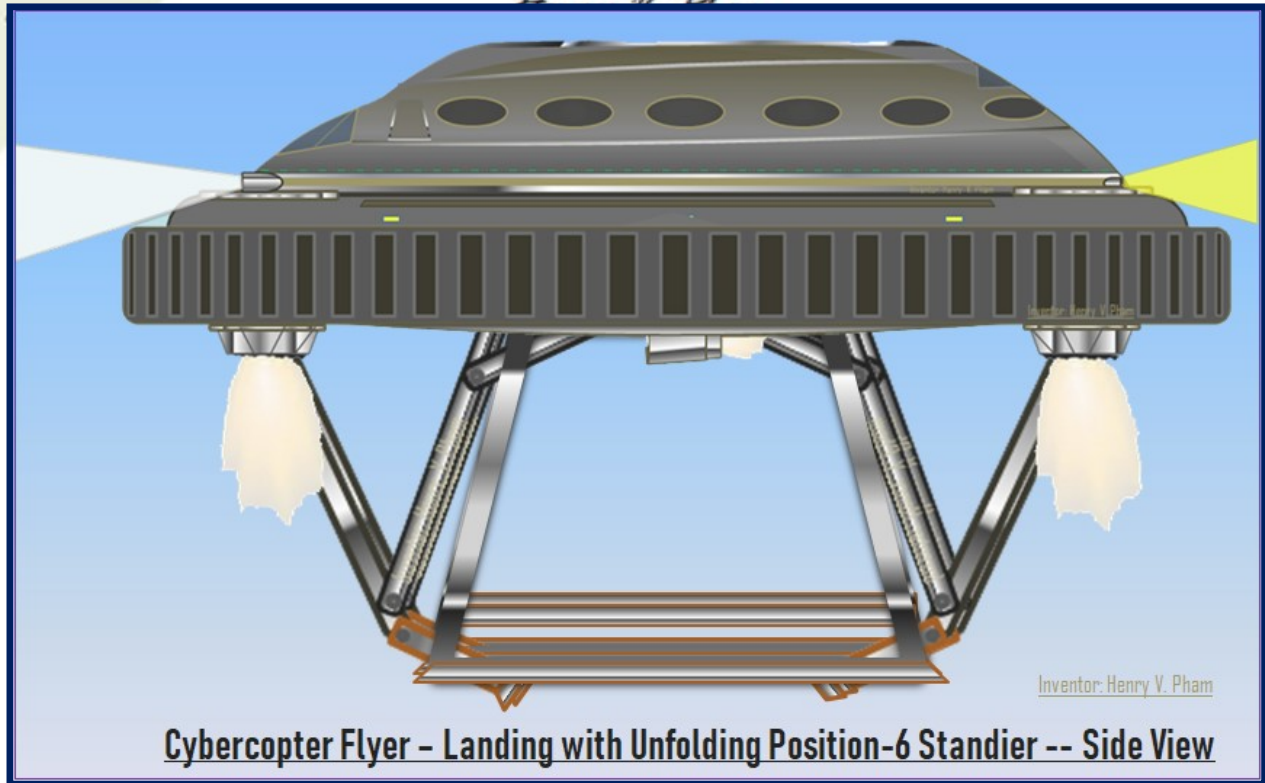

Figure-J6: Cybercopter Flyer - Landing with Unfolding Standier Position 6 (Side view)

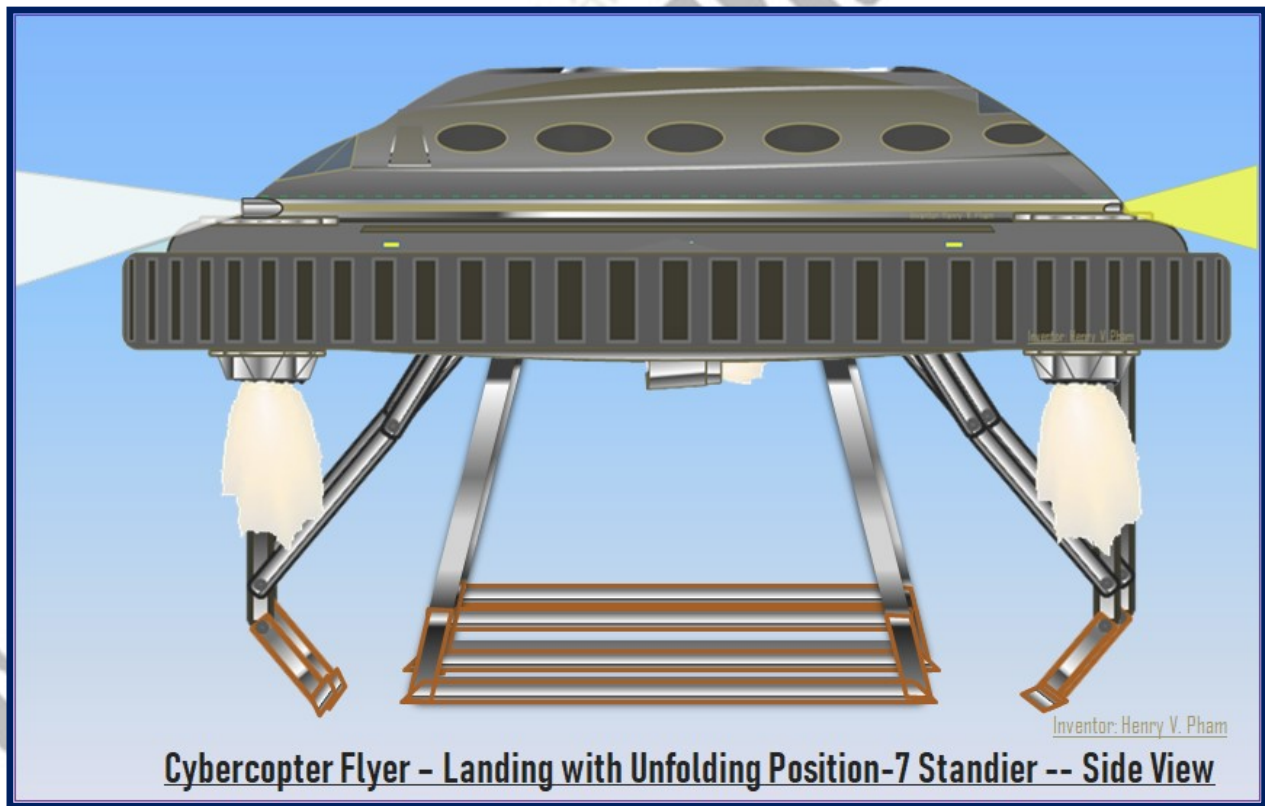

Figure-J7: Cybercopter Flyer - Landing with Unfolding Standier Position 7 (Side view)

Cybercopter Flyer

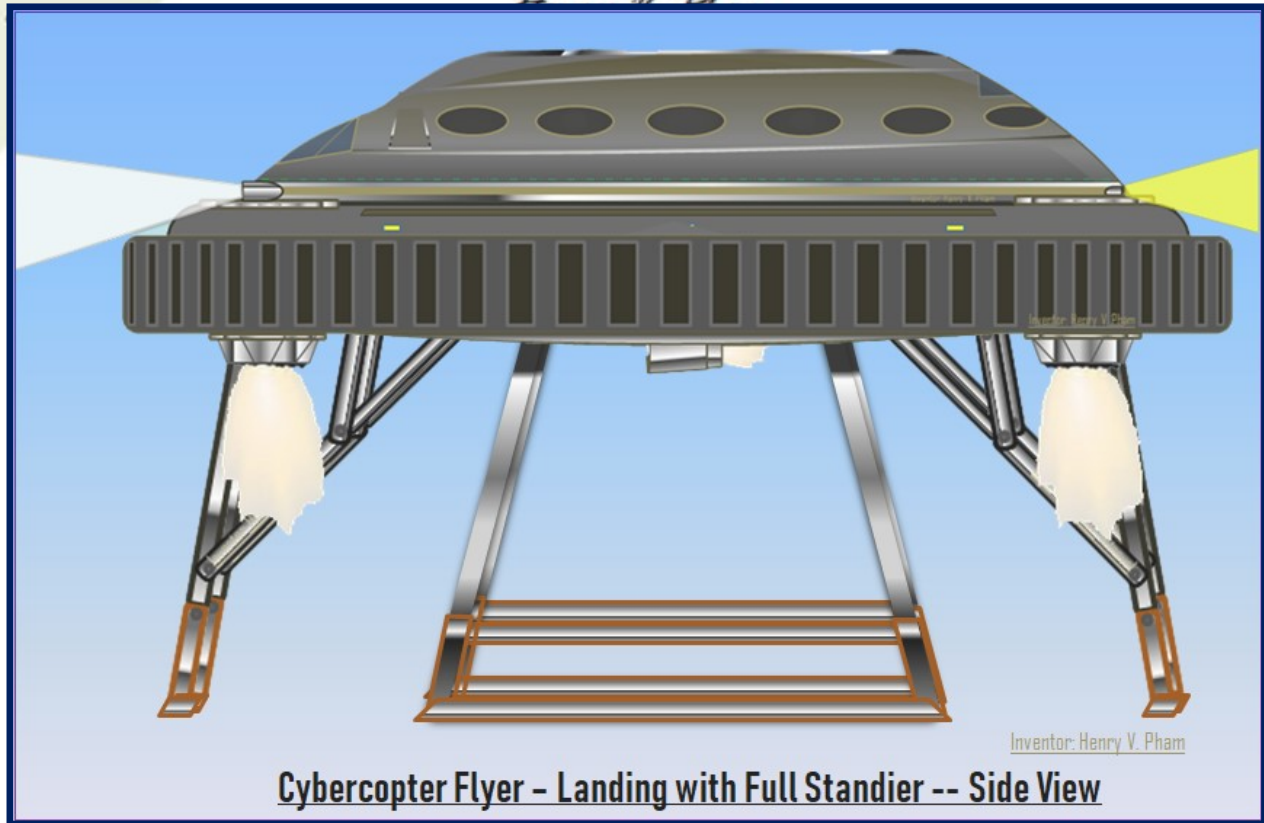

Figure-J8: Cybercopter Flyer - Landing with Full Standier (Side view)

K. Cybercopter Flyer Parking Mode with Stairs Elevadoor Side Views

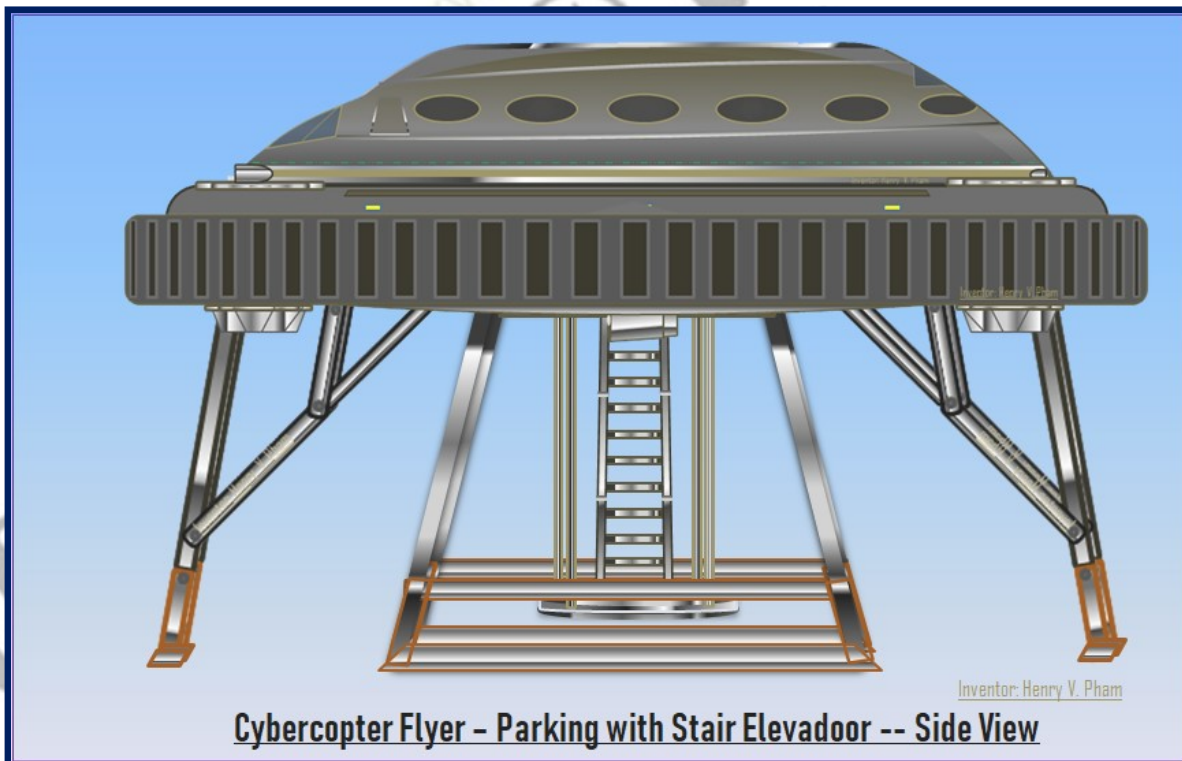
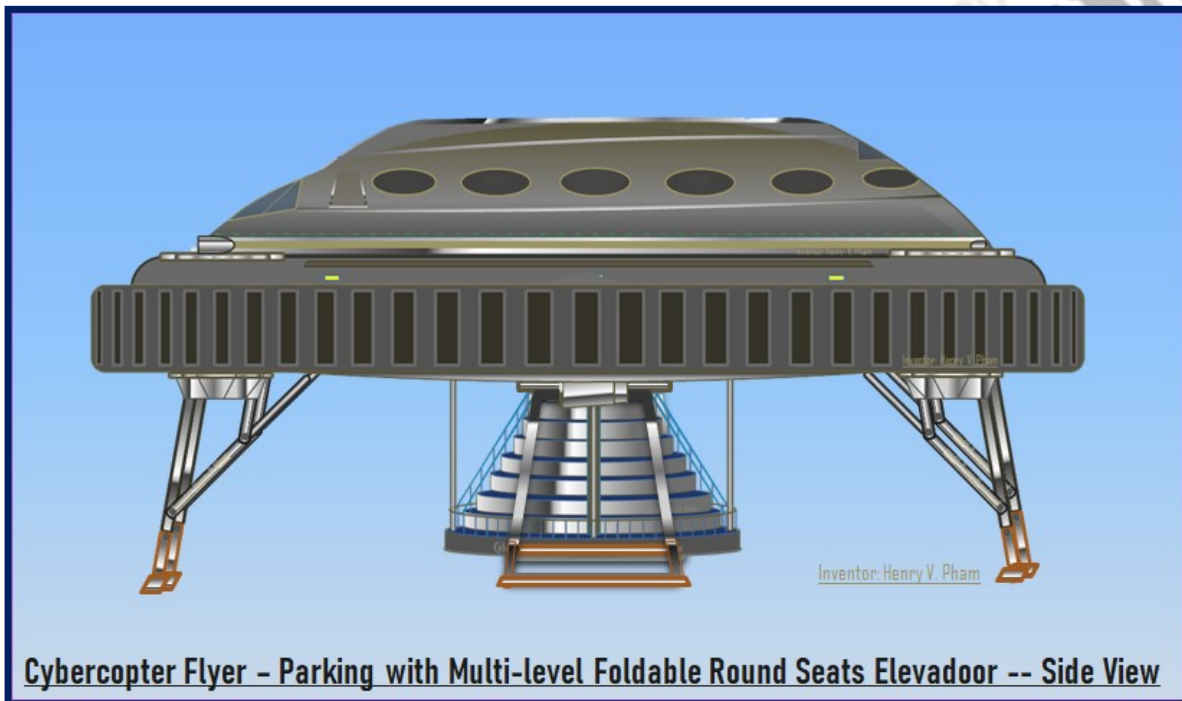

Figure-K1: Cybercopter Flyer - Parking with Stair Elevadoor (Side view)

Cybercopter Flyer

Similar to the front views when the Cybercopter Flyer standier is completely unfolded and the all engines are off, the elevador can be opened for passengers to take off from the flyer. The above **Figure-K1: Cybercopter Flyer - Parking with Stair Elevador (Side view)** shows the Cybercopter Flyer in side view which is parked with the elevador opened with a stair as an option to take off in this drawing. There are more options of the elevador that will be shown detail in later sections, in this section the common stair Elevador is shown in this figure; and the multi-level foldable stair-seat Elevador is shown in **Figure-K2: Cybercopter Flyer - Parking with Multi-Level Foldable Round Seats Elevador (Side view)**. The multi-level foldable ring stair-seat Elevador which is similar to the front views and already mentioned in the previous sections which is introduced for sightseeing and sky diving flyer versions. The Cybercopter Flyer is expected to be a large size and the ring stair-seat in the elevador can be used as the stair for the passengers to take off from the flyer.



Cybercopter Flyer - Parking with Multi-level Foldable Round Seats Elevador -- Side View

Figure-K2: Cybercopter Flyer - Parking with Multi-Level Foldable Round Seats Elevador (Side view)

I. Cybercopter Flyer Takeoff Mode Front Views

The Cybercopter Flyer takeoff vertically is in revert of landing as shown in section “H. Cybercopter Flyer Landing & Unfolding Standier Front Views” with the standier folding while takeoff on the air starting from a complete stopped position on the ground or on the floor level. The below **Figure-L1: Cybercopter Flyer - Takeoff Start Position (Front view)** shows the Cybercopter Flyer at prepared takeoff position. The pilot would lift the up/down joystick to takeoff level, and the flyer control system would start the 4 main vertical thrust engines with more power to lift the flyer up vertically while the other side pushing engines and back pushing engines are stay at the lowest power level. When the Cybercopter Flyer is takeoff to a safe altitude, the pilot can start trigger to fold the standier as a recommendation for safe takeoff and landing just in case the flyer is got into trouble and need to land right after takeoff. Note that the control system should check and warn the pilot if the standier is still unfolded during flying mode.

Cybercopter Flyer

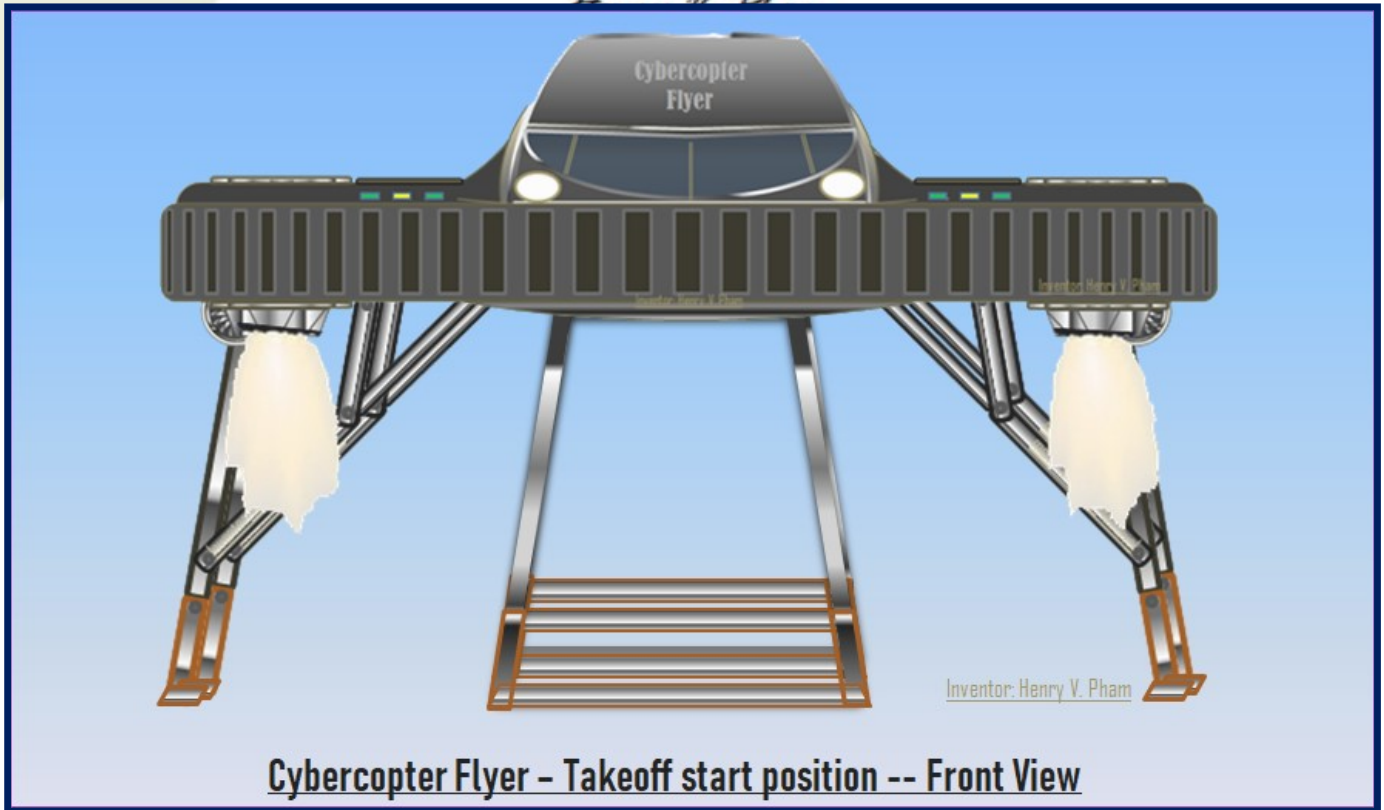

Figure-L1: Cybercopter Flyer - Takeoff Start Position (Front view)

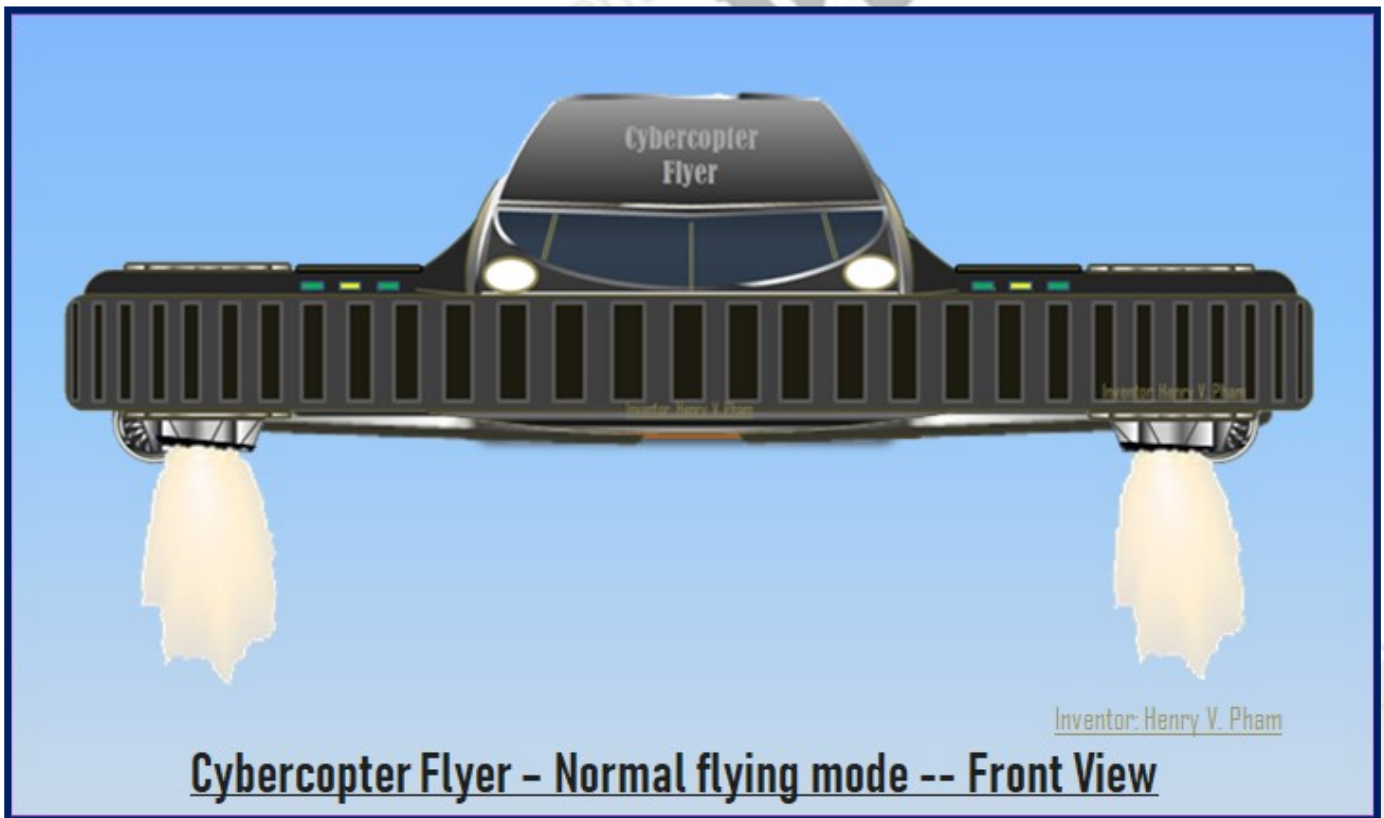

Figure-L2: Cybercopter Flyer - Normal Flying mode (Front view)

Cybercopter Flyer

M. Cybercopter Flyer Takeoff Mode Side Views

The Cybercopter Flyer takeoff vertically in side views is similar to the front views as shown and mentioned above. The below Figure-M1: Cybercopter Flyer - Takeoff Start Position (Side view) shows the flyer is at the prepare to takeoff position in side view; and the Figure-M2: Cybercopter Flyer - Normal Flying mode (Side view) shows the flyer is already takeoff with the standiers are folded with the same steps of folding standier which was mentioned in the previous section.

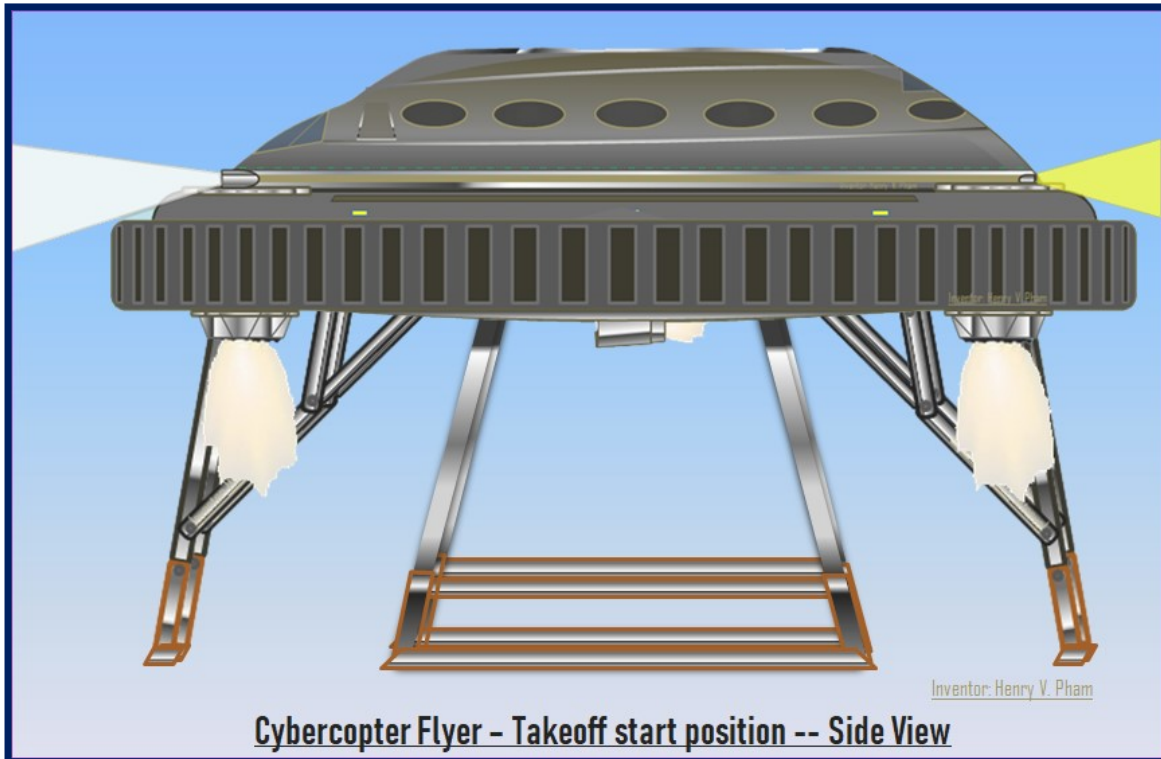

Figure-M1: Cybercopter Flyer - Takeoff Start Position (Side view)

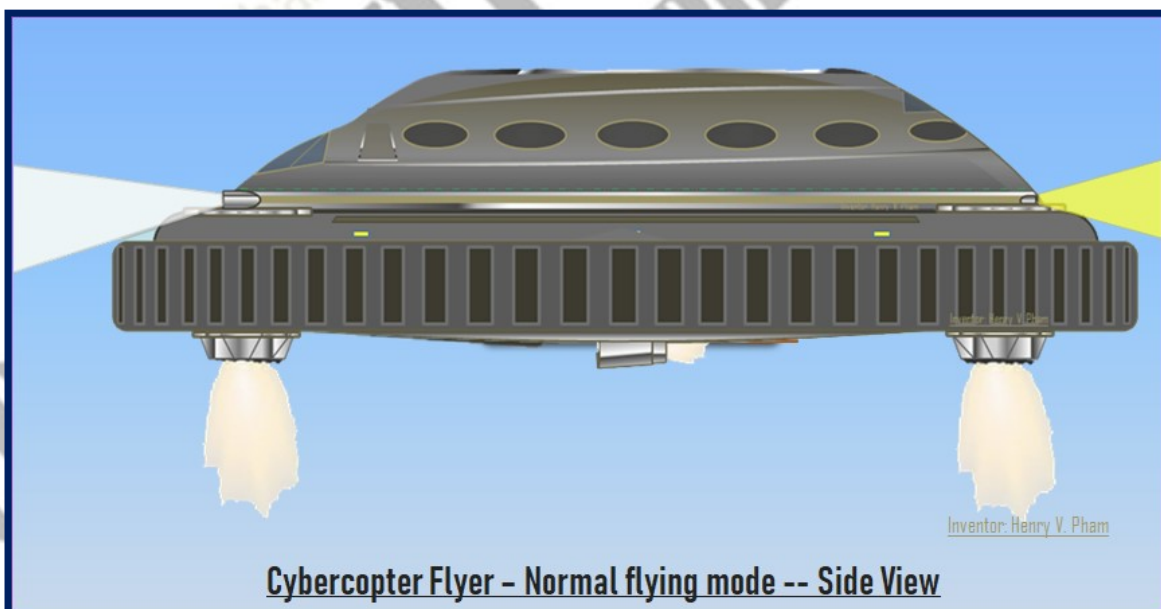

Figure-M2: Cybercopter Flyer - Normal Flying mode (Side view)

Cybercopter Flyer

N. Cybercopter Flyer Folding & Unfolding Standier Mechanism

The Cybercopter Flyer standier mechanism is important for the flyer to landing on the ground or on the floor perfectly so it can able to takeoff and fly again. The standier is recommended to unfold at an angle of 100° degrees compare to the horizontal surface.

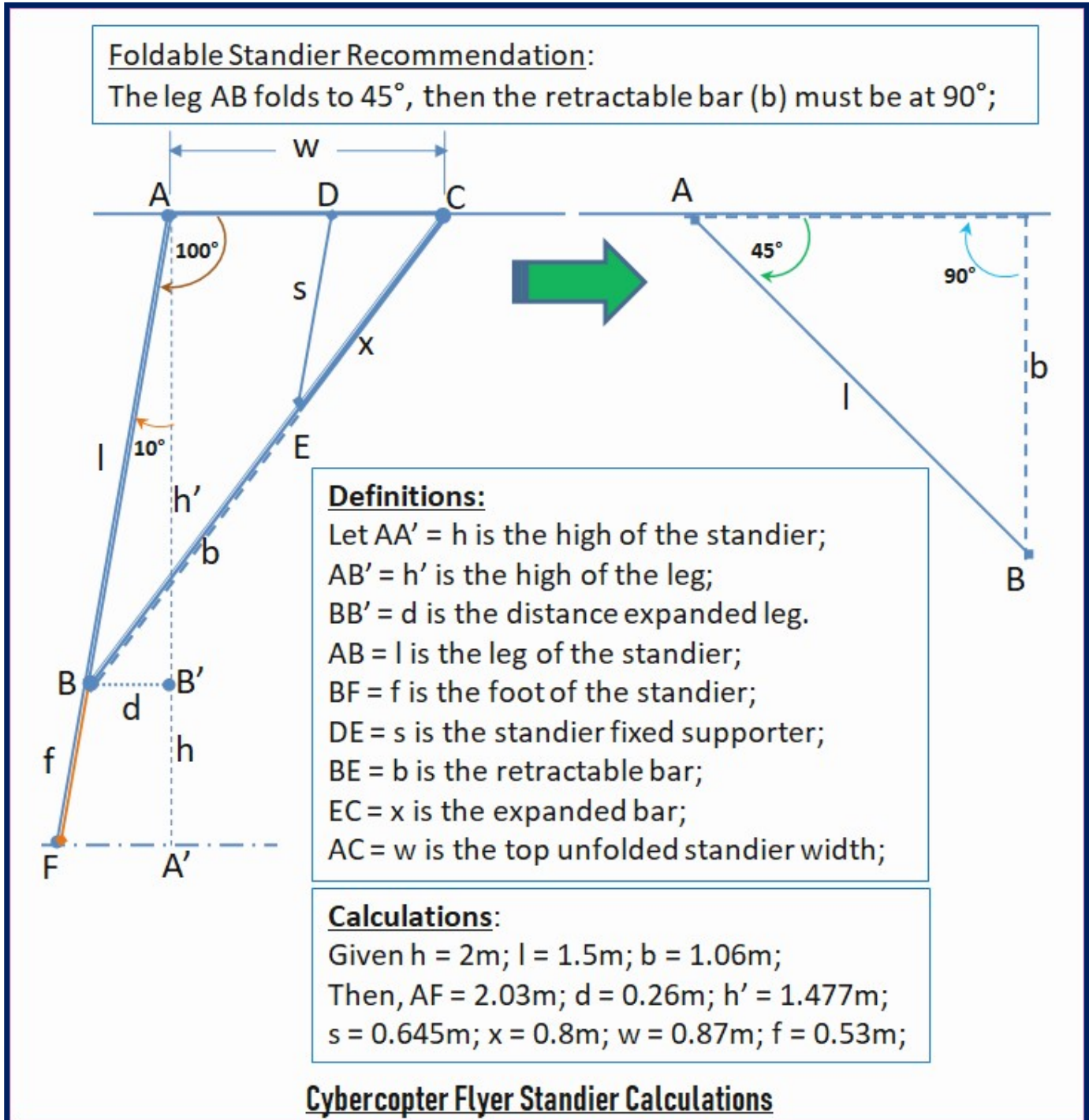

Figure-N1: Cybercopter Flyer Standier Calculations

Cybercopter Flyer

The above **Figure-N1: Cybercopter Flyer Standier Calculations** shows the calculations of the standier that requires the standier with the high of 2 meters and expands to 100° degrees angle. Applying sine and cosine we have,

$\text{Cos}(\beta) = \frac{h}{l}$; $\text{Sin}(\beta) = \frac{d}{l}$; and $(b + x)^2 = h^2 + (w + d)^2$; then $w = \sqrt{((b + x)^2 - h^2)} - d$; where β is the angle BAB' and equals to 10° degrees. As shown in the figure with the definitions of the lines and angles where $h = 2\text{m}$; $l = 1.5\text{m}$; $b = 1.06\text{m}$; then from the above formulas we have, $AF = 2.03\text{m}$; $d = 0.26\text{m}$; $h' = 1.477\text{m}$; $s = 0.645\text{m}$; $x = 0.8\text{m}$; $w = 0.87\text{m}$; $f = 0.53\text{m}$. So, the standier with 2 meters high and expanding in 100° degrees with the leg equals 1.5 meters and the footer (f) equals 0.53 meters ($2.03\text{m} - 1.5\text{m} = 0.53\text{m}$); the retractable bar (b) equals 1.06 meters; the fixed supporter (s) equals 0.645 meters; and the expanded bar in the retractable bar (x) equals 0.8 meters as shown in figure below.

The below **Figure-N2: Cybercopter Flyer - 8 Folding Samples Positions of E-Power Foldable Standier** shows the standier folding in 8 sample positions, and they are described as followings and shown in blue arrows.

1. The first sample position-1 shows all the bars and supporters fully with all the dimensions of the bars and supporters are calculated in the previous drawing. The Standier is straight out and locked the leg and the foot of the standier as shown detail in later sections; the supporter (s) is paralleled with the leg and to support the standier stronger while the retractable bar is expanded the 'x' bar completely.
2. The sample position-2 shows the leg folding at 90° degrees angle with the support gear motors of the leg on the body of the flyer and the foot with motor support to fold in at the same time; the supporter (s) is pulling to push the extractable bar (x) into the retractable bar (b); note that the pulling vector forces are shown in blue arrows, and the motor turning forces are shown in blue curved arrows.
3. The sample positon-3 shows the leg and the foot are closer further to the flyer's body, and the supporter (s) is pulling more to push the extractable bar (x) into the retractable bar (b).
4. The sample positon-4 shows the leg and the foot are closer to the flyer's body; the foot is turned to horizontal position, and the supporter (s) is pulling more to push the extractable bar (x) almost completely into the retractable bar (b).
5. The sample positon-5 shows the leg and the foot are more closer to the flyer's body; the foot is turned to about 90° degrees angle compare to the leg, and the supporter (s) is stopped pulling and the extractable bar (x) is completely pushed into the retractable bar (b).
6. The sample positon-6 shows the leg and the foot are more further closer to the flyer's body; the foot is turned to less than 90° degrees angle compare to the leg, and the supporter (s) is now pushing the retractable bar (b) to fold the standier.
7. The sample positon-7 shows the leg and the foot are almost to the flyer's body; the foot is turned to less than 45° degrees angle compare to the leg, and the supporter (s) is pushing the retractable bar (b) to fold the standier further.
8. Finally, the sample positon-8 shows the leg and the foot is folded completely to the flyer's body; the foot is folded in 180° degrees to the leg, and the supporter (s) is now folded and locked by the slot bar lock that will be shown more detail later; the retractable bar (b) is folded along with the leg. Note that the pulling/pushing forces are in blue arrows, and the motor turning forces are in blue curved arrows.

Cybercopter Flyer

Henry V. Pham

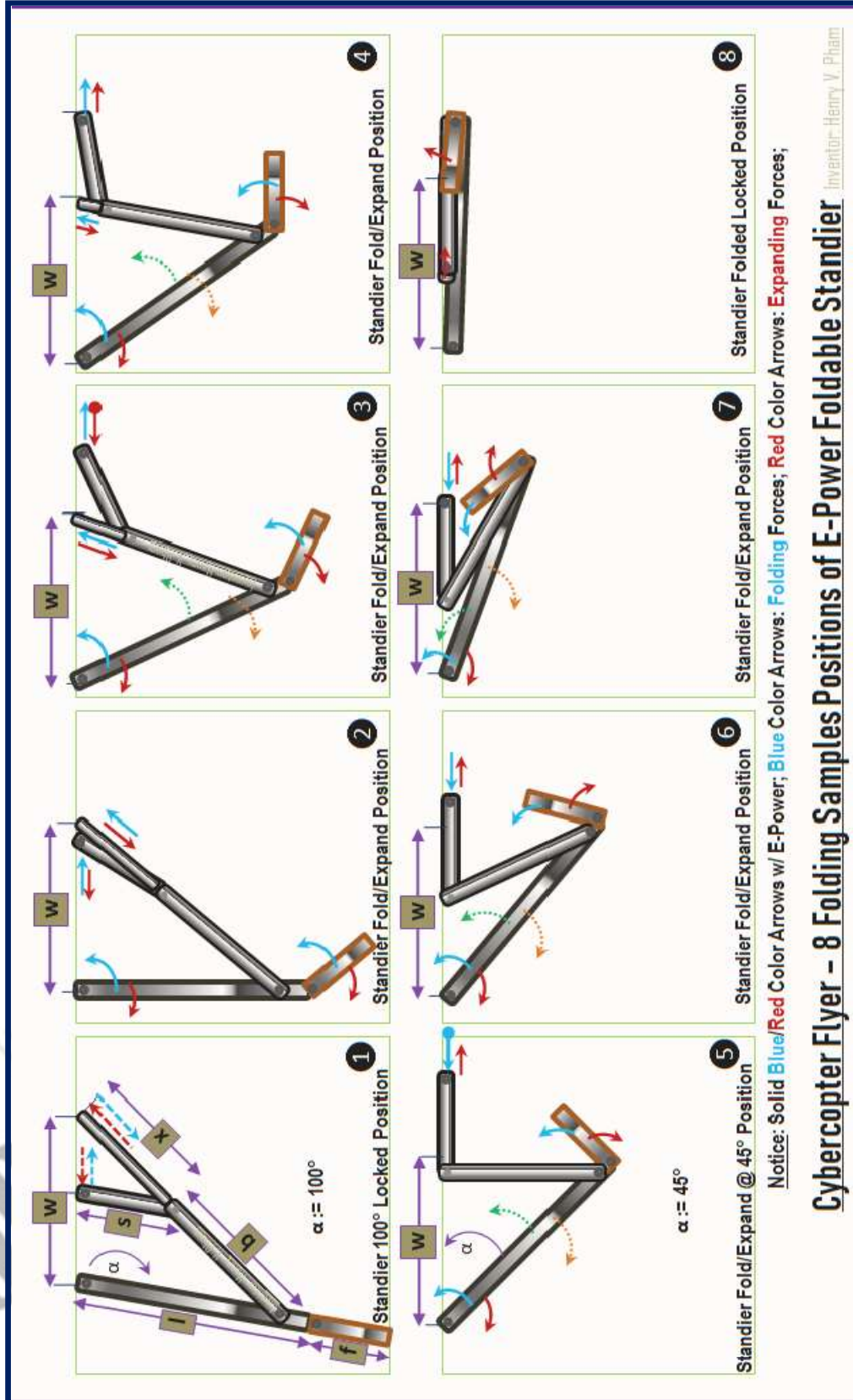

Figure-N2: Cybercopter Flyer - 8 Folding Samples Positions of E-Power Foldable Standier

Cybercopter Flyer

Henry V. Pham

The below Figure-N3: Cybercopter Flyer - 8 Unfolding Samples Positions of E-Power Foldable Standier shows the standier unfolding in 8 sample positions, and they are described as followings and shown in red arrows.

1. The first sample position-1 shows the leg and the foot is fully folded to the flyer's body; when the standier starts to unfold, the foot in orange border would be turned by its gear motor to kick off from the flyer's body while the supporter (s) is started pulling out with help of gear motor of the leg to make the standier unfolding easier and hardly to get stuck. Note that the pulling/pushing vector forces are shown in red arrows, and the motor turning forces are shown in red curved arrows.
2. The sample position-2 shows the foot is kicked off from the flyer's body, and the supporter (s) is pulling out to pull the retractable bar (b) with it. At the same time, the gear motor of the leg turns the leg downward while the foot is turning outward by its motor to unfold the standier.
3. The sample position-3 shows the foot is expanded almost 90° degrees angle compare to the leg, and the supporter (s) is pulling out further to pull the retractable bar (b) with it. At the same time, the gear motor of the leg turns the leg downward while the foot is turning outward by its motor to unfold the standier.
4. The sample position-4 shows the foot is expanded about 90° degrees angle compare to the leg, and the leg is turning downward to 45° degrees; the supporter (s) is pulling out to pull the retractable bar (b) to 90° degrees angle. At the same time, the gear motor of the leg turns the leg downward while the foot is turning outward by its motor to unfold the standier.
5. The sample position-5 shows the foot is expanded more than 90° degrees angle compare to the leg, and the leg is turning downward more than 45° degrees; the supporter (s) is pulling out further to pull the retractable bar (b) more than 90° degrees angle and pull the extractable bar (x) out of the retractable bar (b). At the same time, the gear motor of the leg turns the leg downward while the foot is turning outward by its motor to unfold the standier.
6. The sample position-6 shows the foot is expanded more further than 90° degrees angle compare to the leg, and the leg is turning downward more further than 45° degrees; the supporter (s) is pulling out further to pull the retractable bar (b) more than 90° degrees angle and pull the extractable bar (x) out of the retractable bar (b). The supporter (s) is pulling out while the gear motors turn the leg and the foot downward further and stopped at the position when it is in parallel with the retractable bar (s) and the extractable bar (x).
7. The sample position-7 shows the foot is expanded more further, and the leg is turning downward to 90° degrees angle; the supporter (s) is now pushing to push the retractable bar (b) to 90° degrees angle and pull the extractable bar (x) out of the retractable bar (b). At the same time, the gear motor of the leg turns the leg downward further while the foot is turning outward by its motor to unfold the standier.
8. Finally, the sample position-8 shows the foot is expanded straight out with the leg at 100° degrees angle and locked with the leg lock which will be shown detail in later section; the supporter (s) is now pushed to the last position where it is paralleled with the leg while the extractable bar (x) is pulled out to its maximum length. The Standier is now unfolded completely with the leg at 100° degrees angle.

Cybercopter Flyer

Henry V. Pham

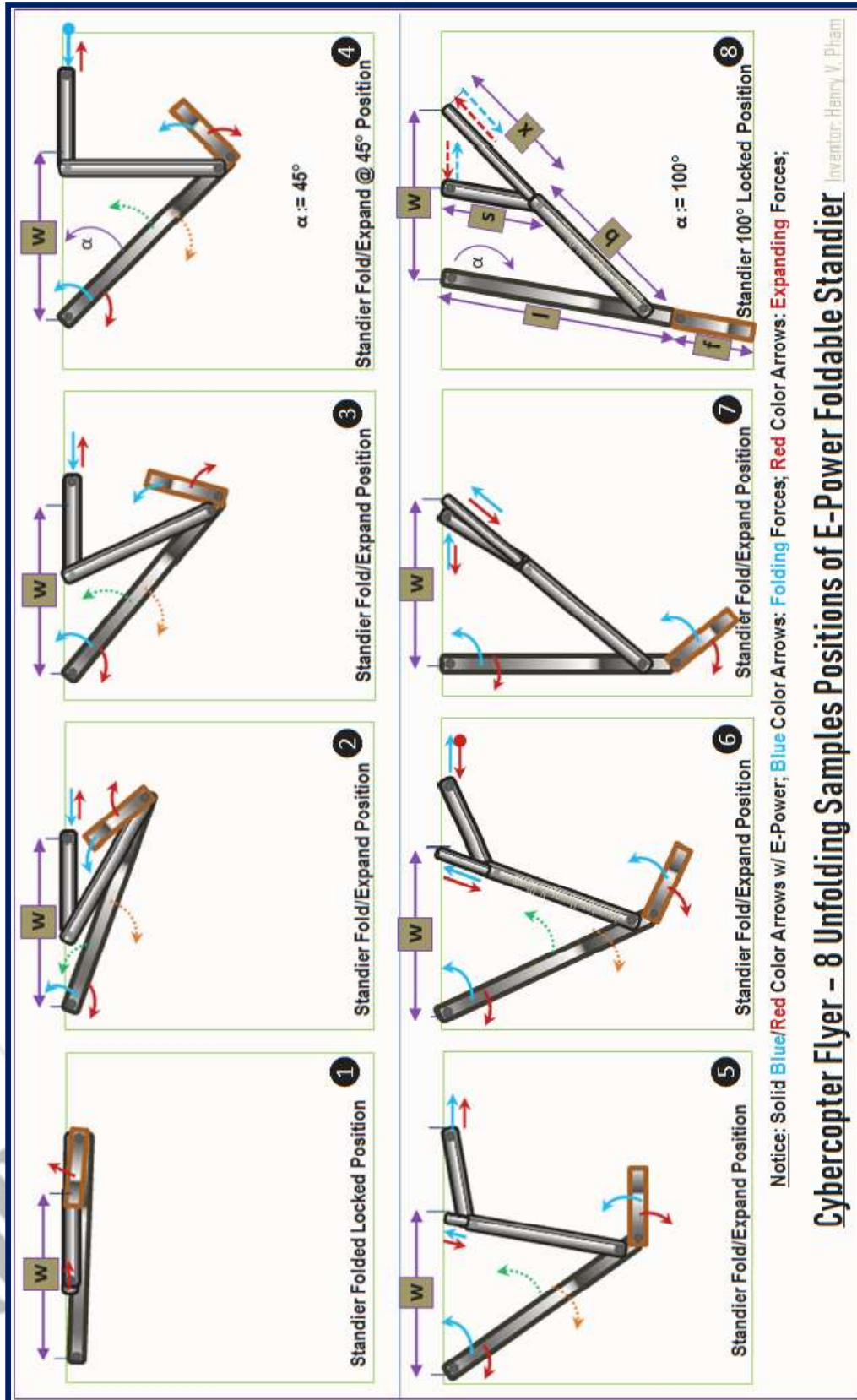

Figure-N3: Cybercopter Flyer - 8 Unfolding Samples Positions of E-Power Foldable Standier

Cybercopter Flyer

Henry V. Pham

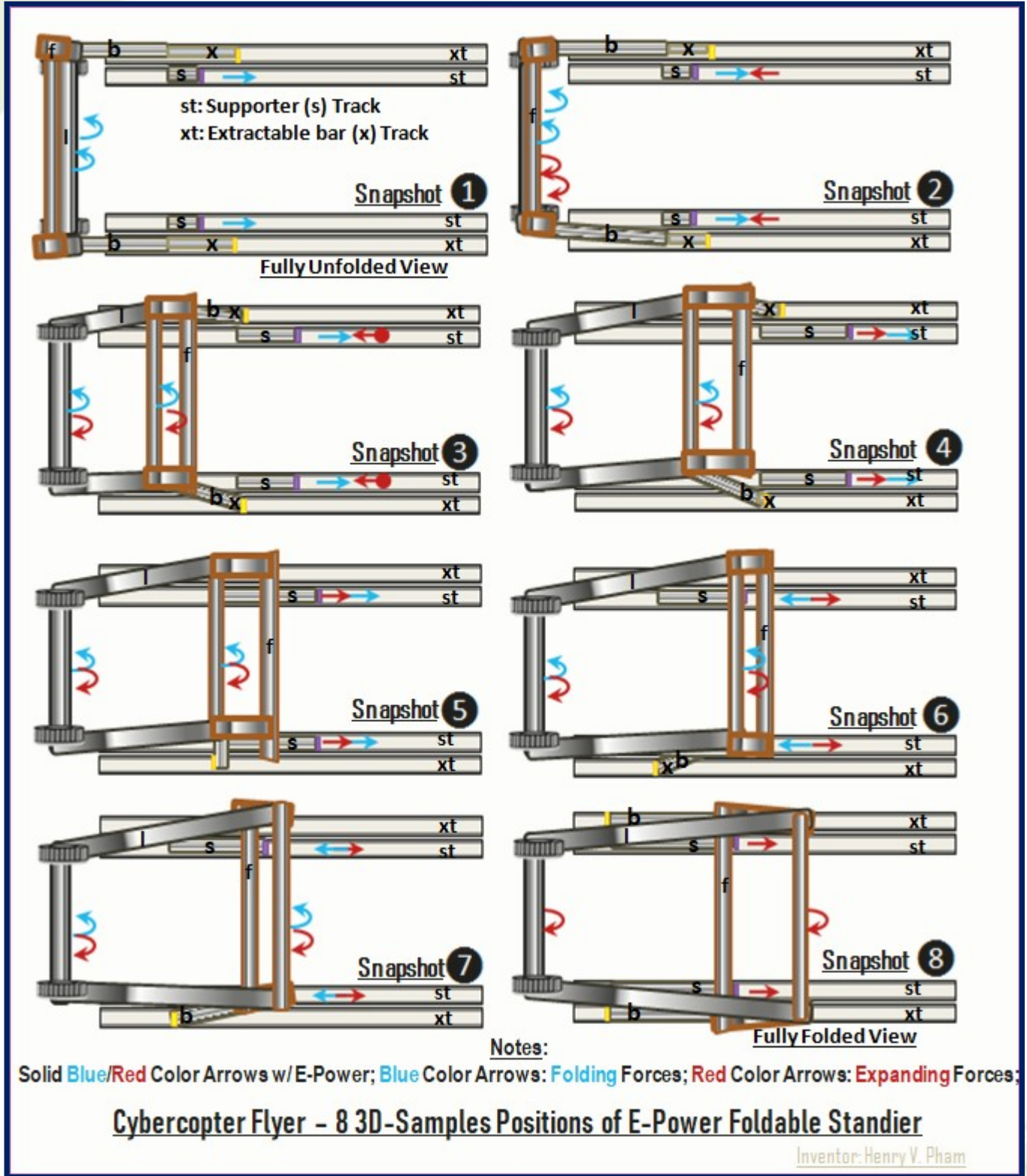

Figure-N4: Cybercopter Flyer - 8 Unfolding Samples Positions of E-Power Foldable Standier

Cybercopter Flyer

The above **Figure-N4: Cybercopter Flyer - 8 Unfolding Samples Positions of E-Power Foldable Standier** shows the 8 samples snapshots in 3D views of the standier of folding in blue arrows and unfolding in red arrows. As described previously for the above 2 figures for folding and unfolding in 8 sample positions, this figure shows similar in 8 steps snapshots in different views; the snapshot-1 shows the fully unfolded view, and the snapshot-8 shows the fully folded view. This figure shows the supporter (s) sliding on the Supporter Track (st) and the extractable bar (x) sliding on the Extractable bar Track (xt). The supporter (s) pushes and pulls the retractable bar (b) to push or pull the extractable bar (x) in or out of the retractable (b) in similar steps as shown in the other 2 figures above. Note that the snapshot numbers in this figure are matching with the sample position numbers in **Figure-N2: Cybercopter Flyer - 8 Folding Samples Positions of E-Power Foldable Standier**; and the snapshot numbers in this figure are matching in revert with the sample position numbers in **Figure-N3: Cybercopter Flyer - 8 Unfolding Samples Positions of E-Power Foldable Standier**.

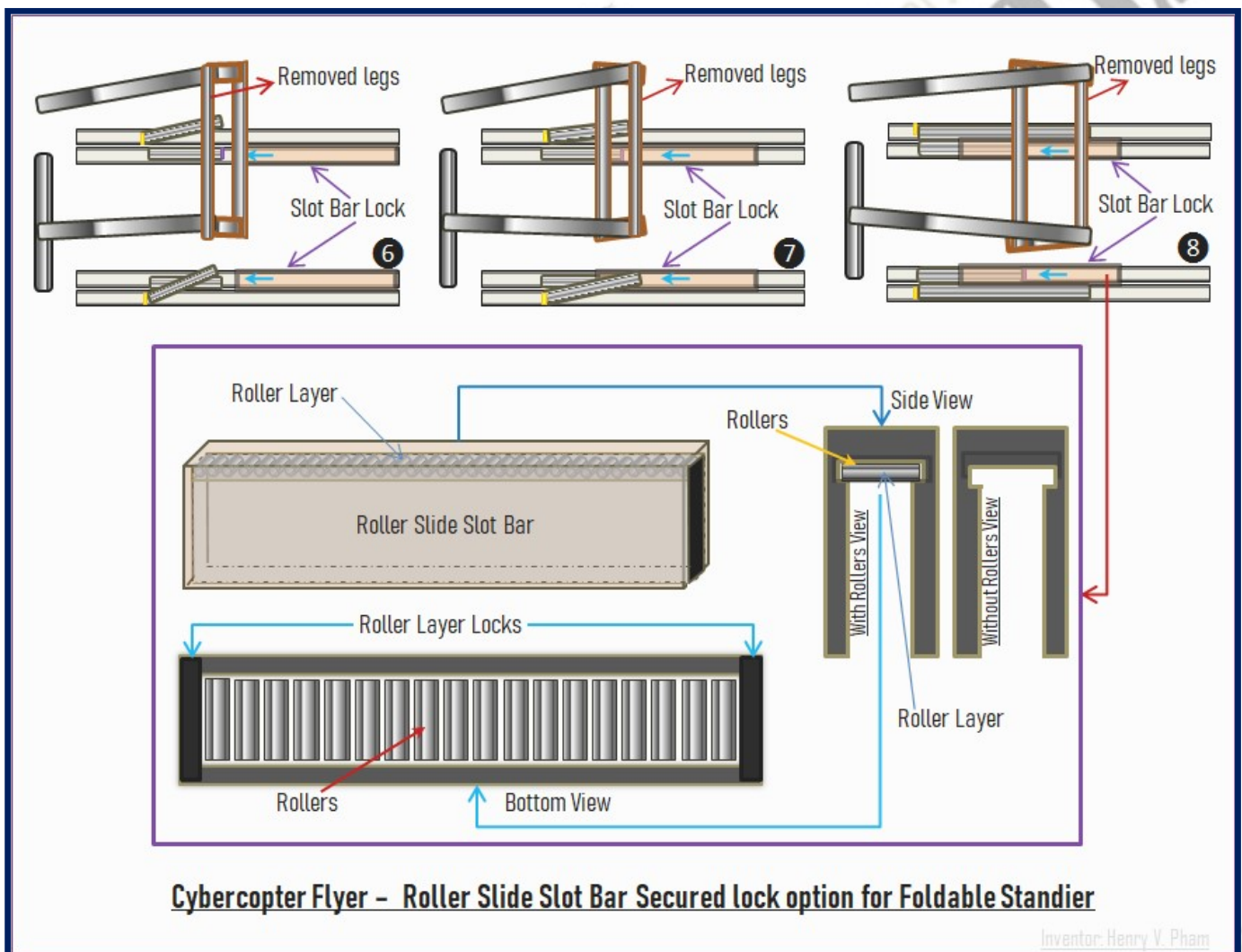

Figure-N5: Cybercopter Flyer -Roller Slide Slot Bar Lock Option for Foldable Standier

The Cybercopter Flyer Standier is also recommended with Roller Slide Slot Bar option to lock the standier to keep the standier stay folded while the Cybercopter Flyer is in flying mode. The Roller Slide Slot Bar is used to slide and follow the supporter (s) to lock the standier when the supporter (s) is moving

Cybercopter Flyer

into the last folding position and is used to pull out to unlock the standier before the foot and leg of the standier start to kick off from the flyer's body to unfold; and this process is needed less friction as possible, and the rollers in the Roller Slide Slot Bar would help in this case. The above **Figure-N5: Cybercopter Flyer - Roller Slide Slot Bar Lock Option for Foldable Standier** shows on top with the 3 sample positions from **Figure-N4** with the legs removed for a clearer view of the Slot Bar Lock which is the Roller Slide Slot Bar. The Roller Slide Slot Bar is shown at the bottom of the drawing which comes with the roller layer; the roller layer is built with array of rollers which would help to reduce the friction when it is moving in or out from the supporter (s) to support the standier fold or unfold easier.

As mentioned above, the standier would come with gear motors to turn the leg and the foot of the standier while it is folding or unfolding. The below **Figure-N6: Cybercopter Flyer - Upper and Lower Legs Joint sections of Standier** shows the leg with axel gear and the powered gear motor which is built in the flyer's body to turn the gear axel of the leg that makes the leg turns when the standier is folding or unfolding. The foot or the lower leg of the standier also comes with the powered gear motor which is located right at the knee of the upper leg to turn the gear axel of the foot or the lower leg when the standier is folding or unfolding.

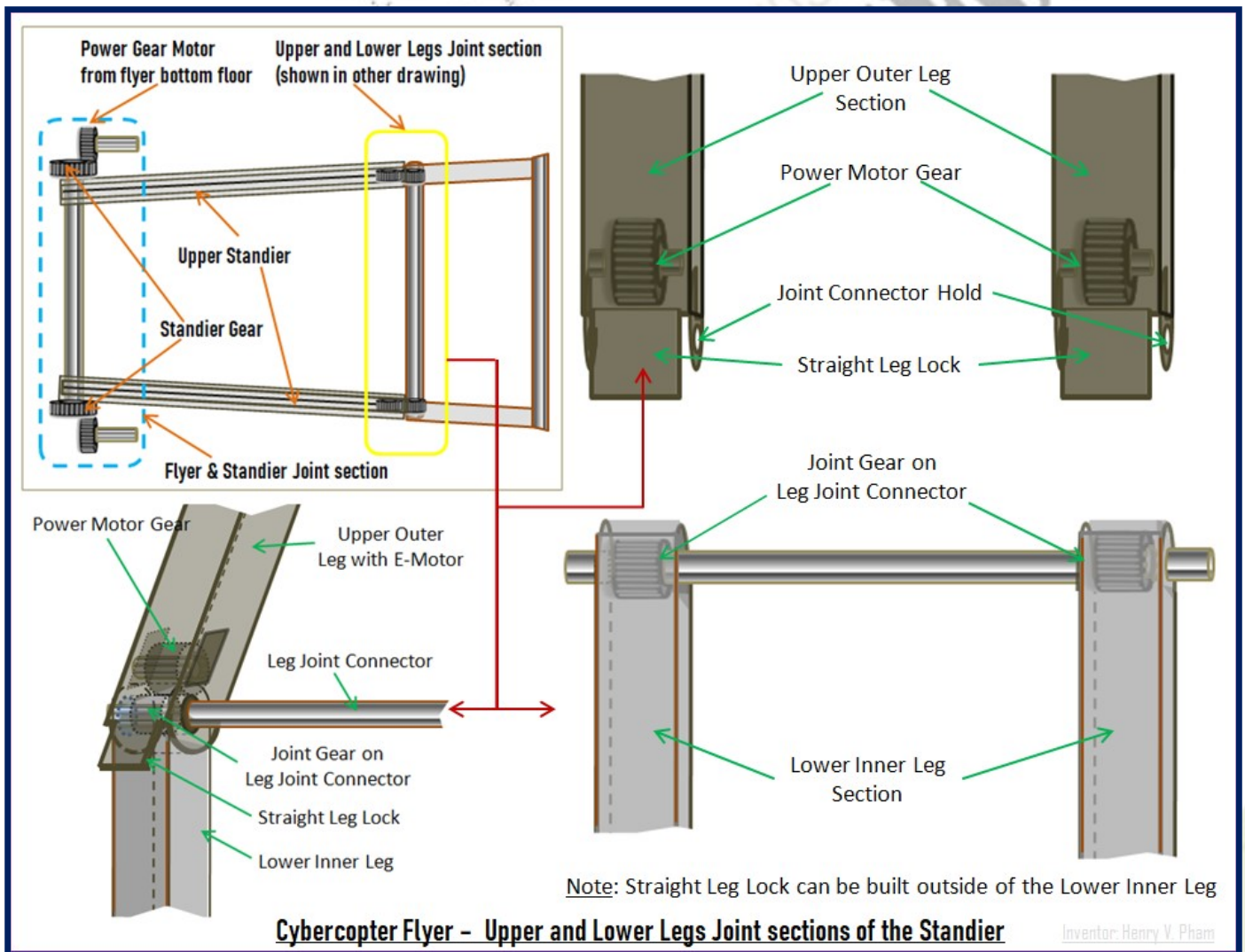

Figure-N6: Cybercopter Flyer - Upper and Lower Legs Joint sections of Standier

Cybercopter Flyer

0. Cybercopter Flyer Elevadoor Options

The Cybercopter Flyer would come with the elevadoor which is the elevator that has a door or stair to access. The Cybercopter Flyer with big sizes and more spaces can have one or more elevadoors and with one or more traditional stairs like the existing airplanes for passengers to access faster. However, the elevadoor showing in this invention document is used for the common sizes of the Cybercopter Flyer which is about the size of the regular helicopter; the helicopter has the blades spinning on top that could cover the circle area of about 5 meters in diameter.

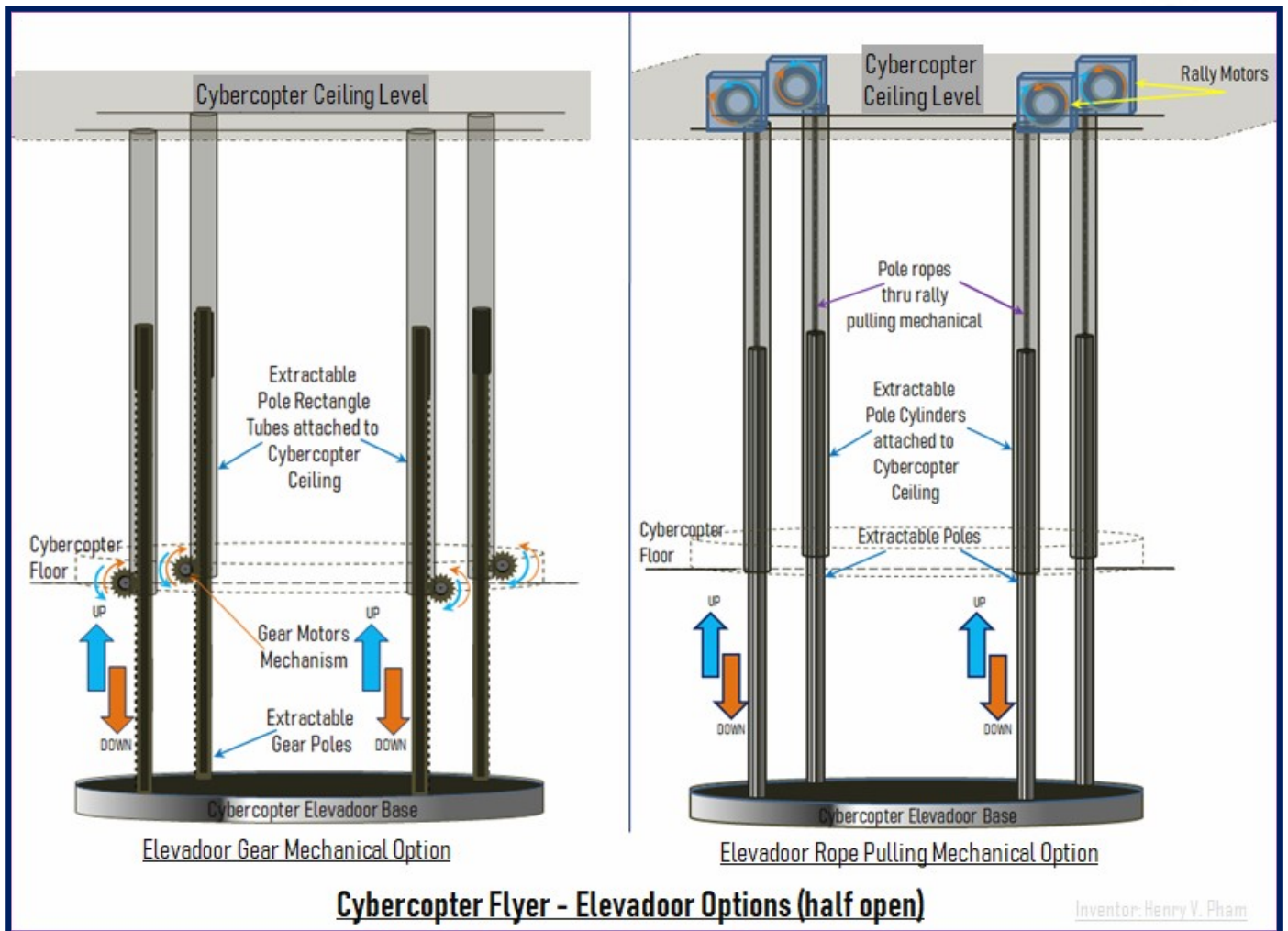

Figure-01: Cybercopter Flyer -Elevadoor Options (half open view)

The above **Figure-01: Cybercopter Flyer -Elevadoor Options (half open view)** shows the elevadoor with half open in 2 different options without any stairs on it; there are several stairs options will be shown later in this section. The drawing on the left shows the elevadoor with gear mechanical option, and the one on the right shows the elevadoor with cables pullers; both elevadoor options would have the retractable poles attached to the flyer's ceiling frame. The elevadoor Gear Mechanical option would have the gear motors installed at the floor level to turn the gear bars to extract the gear bars out of the retractable poles to open the elevadoor in downward direction as shown in orange arrows; and the gear motors turning

Cybercopter Flyer

directions are shown in orange curved arrows. On the other hand, the elevadoor Rope Pulling Mechanical option would have rally motors installed on the ceiling level which are used to roll the cables up or release the cable to let the elevadoor moving downward with the air pushing mechanical which is commonly use long time in today technology. The elevadoor is required to open fully for access, and it is recommended to keep about 1 foot above the ground or landing level for safety purposes and to protect the elevadoor from touching on the hard surface; note that the standier is recommended with 2 meters high and higher for the big size Cybercopter Flyer which are used for transportation services. The below **Figure-02: Cybercopter Flyer - Elevadoor Options (full open view)** shows the elevadoor in 2 different options with fully open. The stair is not showing in this drawing, and any options of attached stairs would be installed on the elevadoor base and attached the hangers to the Cybercopter Flyer's floor level; and all the attached stairs would be foldable stairs so that when the elevadoor is folding or unfolding, the attached stairs would be folded or unfolded with the elevadoor respectively. There are several options of foldable stairs are shown later in this section to provide as the options for the Cybercopter Flyer access door; however, other foldable stairs which are safe and suitable for Cybercopter Flyer are acceptable.

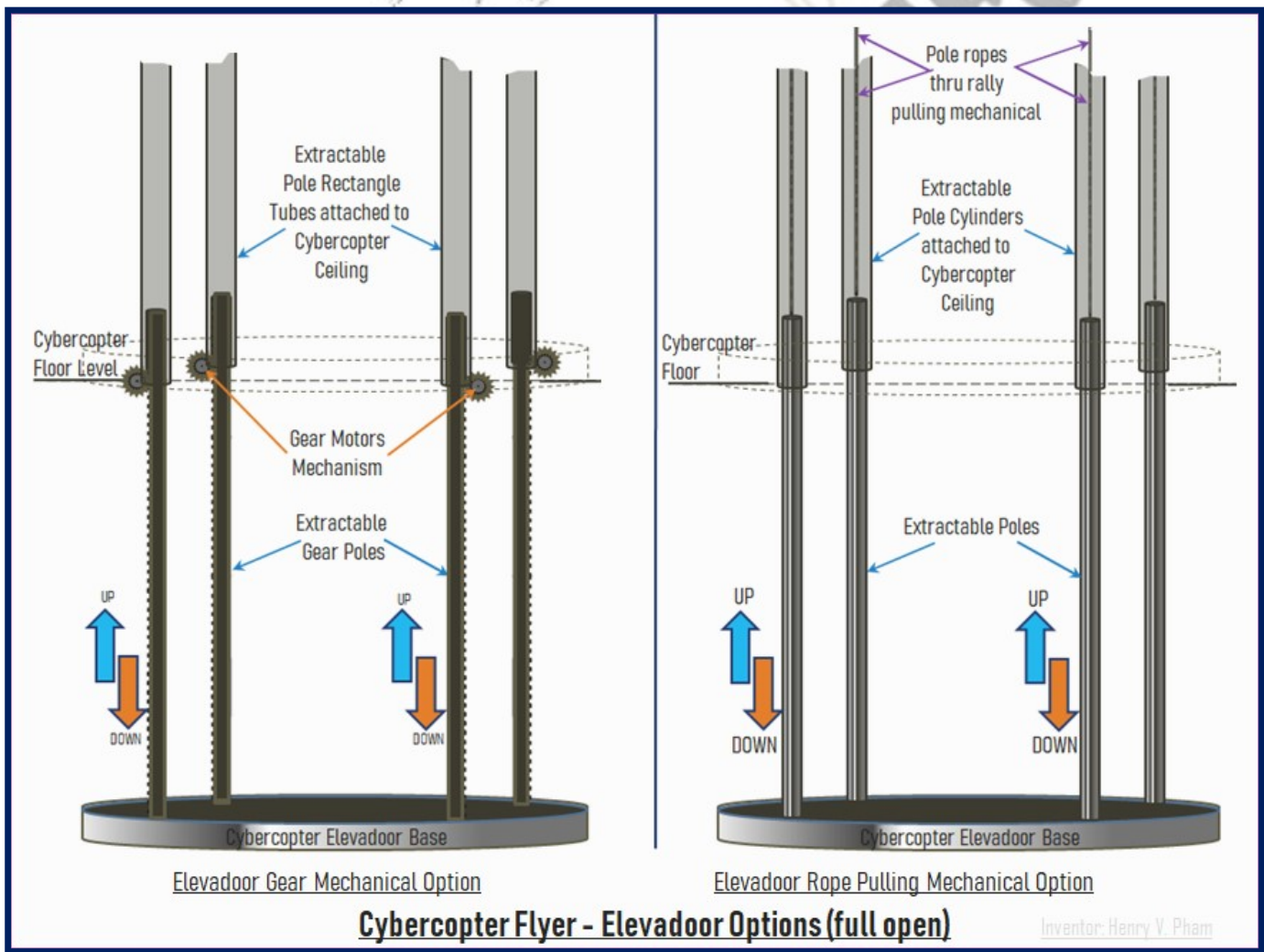

Figure-02: Cybercopter Flyer – Elevadoor Options (full open view)

Cybercopter Flyer

Henry V. Pham

1. Cybercopter Flyer Slide-Foldable Ladder Elevadoor

The above section described the elevadoor for Cybercopter Flyer with 2 options with the opened base that would be added this Slide-Foldable Ladder as one of the foldable ladders or foldable stairs for flyer access. The **Figure-03: Cybercopter Flyer – Elevadoor Base & Slide-Foldable Ladder** below shows the Slide-Foldable ladder as a foldable stair on the elevadoor base; this foldable ladder would come with 5 sections which are unfolded with enough length from the floor level to the elevadoor base when the elevadoor is unfolded completely; note that the length of each section can be adjusted to match the length of the entire unfolded ladder depends on the length 'L' and the elevadoor base with radius r; and as mentioned in the previous sections, the elevadoor is above the ground 1 foot and the standier high is 2 meters tall as recommended. The elevadoor base for this foldable ladder would be open on one half with the high 'z' which can hold all 5 ladder sections when folded. The elevadoor base would have a fixed lock holder on top half as marked in yellow rectangle which has the length 'm' to fit part of the lower folded ladder sections except the upper section; the upper section would have a joint connected to the Fixed Lock Holder which total length 'k' as shown in the figure below. The upper folded ladder section with a joint connected to the elevadoor base is tied to the base when the elevadoor is unfolded; and the lower ladder section would have a joint which is connected to the flyer floor level that can provide a straight ladder when unfolded fully. Note that the elevadoor would have 4 strong retractable poles either with gear motor or rope puller mechanical as recommended and described in the earlier section.

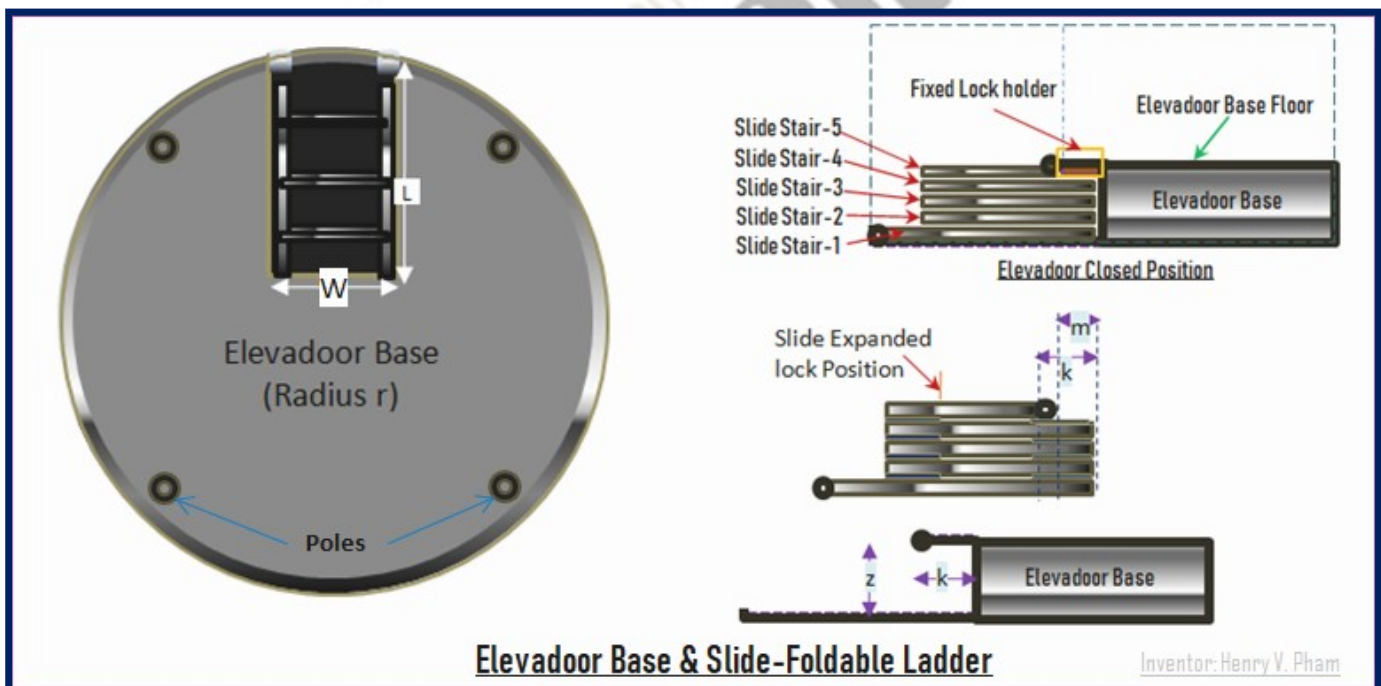

Figure-03: Cybercopter Flyer – Elevadoor Base & Slide-Foldable Ladder

The below **Figure-04: Cybercopter Flyer – Elevadoor Base & Slide-Folded Ladder Operation modes** shows the Slide-Foldable ladder with fully unfolded view and the start of unfolding views. Each foldable ladder section would have a connection section from one to another which will be shown detail in next figure.

Cybercopter Flyer

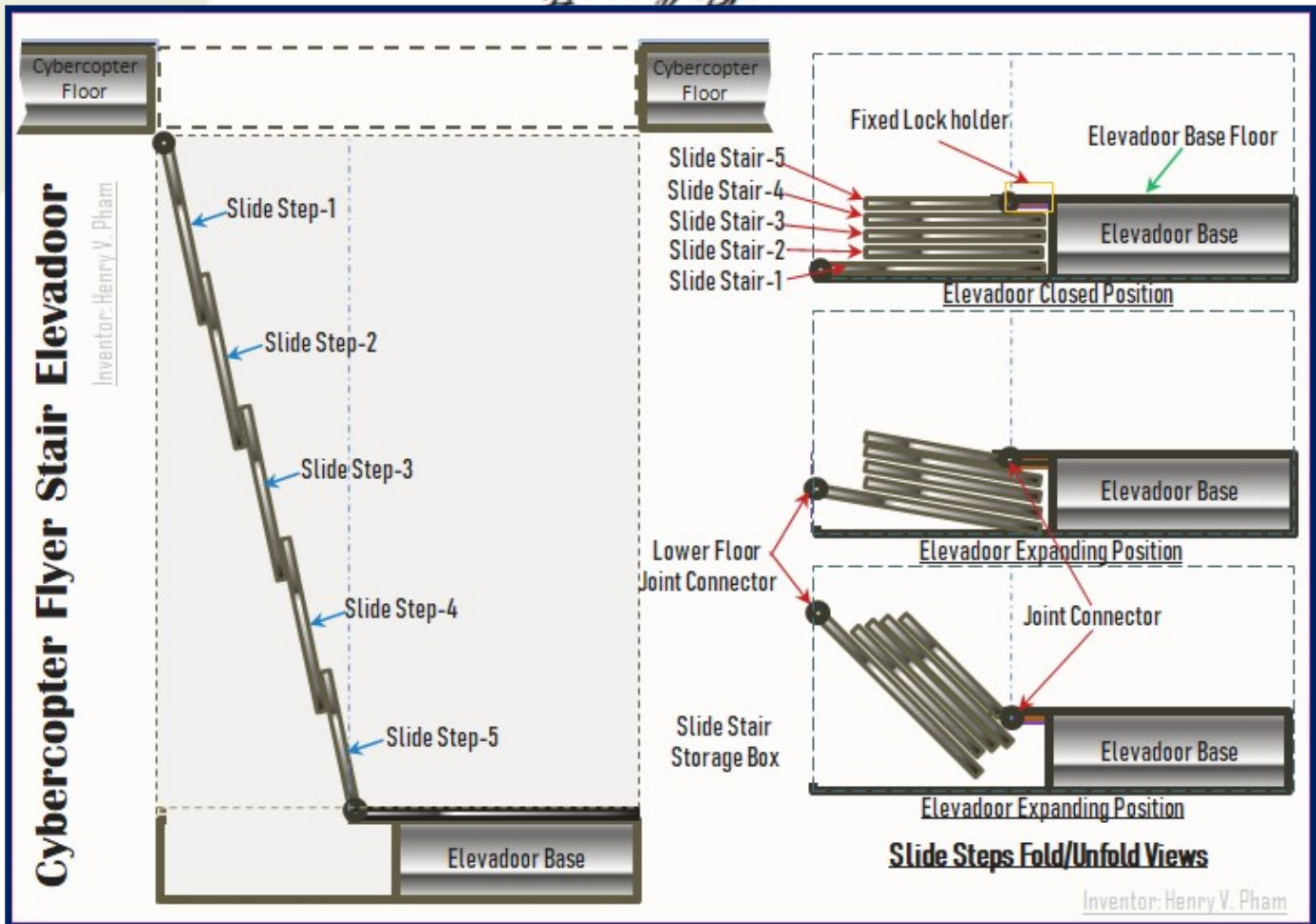

Figure-04: Cybercopter Flyer – Elevadoor Base & Slide-Folded Ladder Operation modes

The top right drawing shows the foldable ladder in fully folded view, and the 2 lower right drawings show the starting moments of unfolding positions and as the same as the ending moments of the folding positions; note that other folding or unfolding positions at higher raise are more easier to understand are not showing here.

Figure-05: Cybercopter Flyer – Elevadoor Base & Slide-Foldable Ladder Details shows details of the foldable ladder section. The foldable ladder section would have upper slide bar on both sides and lower slide slots on both sides as a pair to slide on top of each other. The foldable ladder upper and lower sections are shown in the figure with the labels 's' is the width of the slide bar open slot; 'w₁' is the larger width of the slide bar (lock bolt); 'w₂' is the smaller width of the slide bar. The slide lock has the width equals to 'w₂' to hold and lock the slide bar bolt ('w₁' > 'w₂'). The upper slide bar is recommended with the width of 1¼ to 2 inches, and the difference between 'w₂' and 'w₁' is recommended about ½ to 1 inch; the open slide slot 's' is recommended with at least ½ inch. Note that the ladder step width 'L' which is shown in **Figure-03** above is recommended with at least 15 inches or a small standard size ladder. The top right drawing shows the 2 ladder sections on top of each other as shown level-1 and level-2 stair steps; and the level-2 ladder section on top shows the slide bar in dark color and the slide bar head bigger with orange border which is used as a lock when the ladder section slide all the way out to the top as shown in the bottom drawing.

Cybercopter Flyer

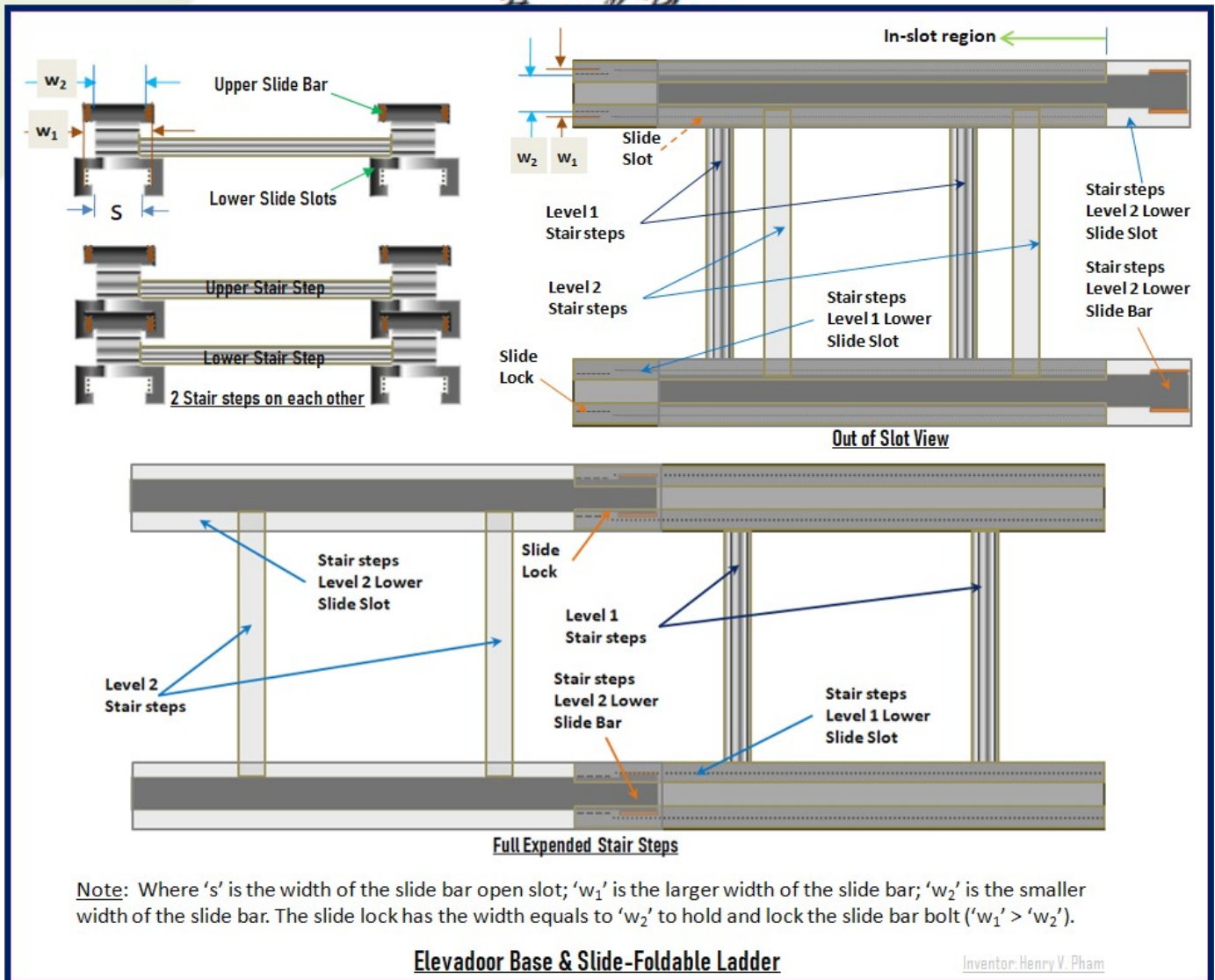

Figure-05: Cybercopter Flyer – Elevador Base & Slide-Foldable Ladder Details

2. Cybercopter Flyer Chain-Foldable Ladder Elevador

The Cybercopter Flyer would have Chain-Foldable ladder for the elevador as another option. **Figure-06: Cybercopter Flyer – Foldable Chain Ladder Mechanism** shows the Chain-Foldable ladder with 3 folding levels, which is controlled by gear motor mechanical with electromagnet locks. The top right drawing shows the chain ladder is fully folded into the elevador base in 3 levels; each level would have the round latch lock on the side which is attached to the belt to rollout and release the chain. The chain belt is controlled by the step gear motor to roll the belt with the synchronization speed of the elevador for better folding/unfolding mechanism; the electromagnet latch lock is released to unlock when it reaches to the end for unfolding, and the latch lock is pulled out to hold and push the chain ladder down and roll with the gear powered chain belt to fold the ladder. Note that the electromagnet latch lock device is widely used in current market. The process of folding and unfolding are shown more in the next drawings.

Cybercopter Flyer

Henry V. Pham

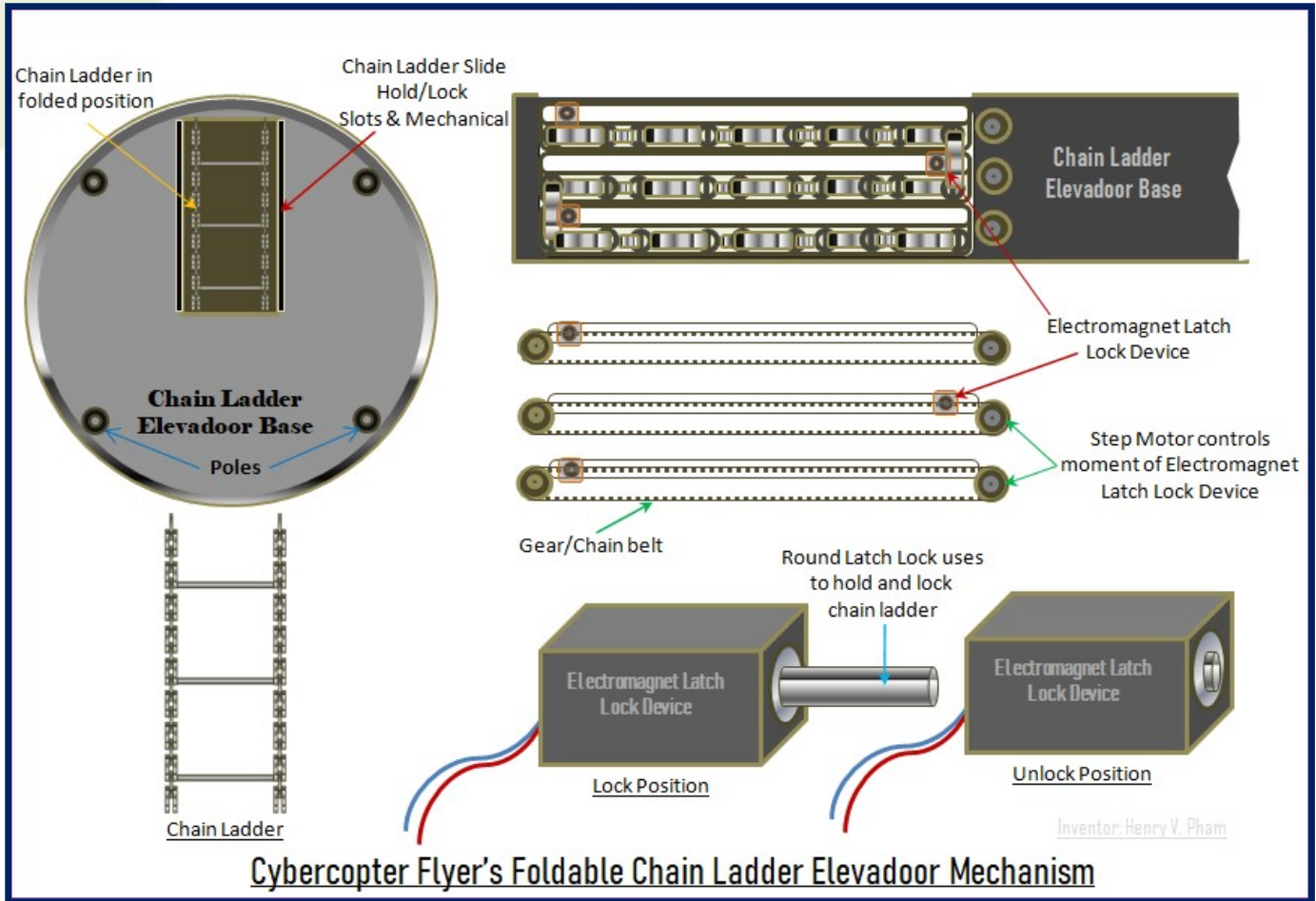

Figure-06: Cybercopter Flyer – Foldable Chain Ladder Mechanism

Figure-07: Cybercopter Flyer –Chain-foldable Ladder Unfolding mode shows the top view the foldable chain ladder in unfolding mode. The left drawing shows the first unfolded level with the round latch lock is pulling out by the gear powered chain belt to release the chain ladder top section when the elevadoor is moving downward while the foldable chain ladder is attached one side to the flyer floor level as the hanger side showing on the drawing. The latch lock is unlocked before it is reached to the end; at the same time, the lower level latch lock is rolling out by the gear powered chain belt to release the chain ladder section of this level. Similarly, the unfolding mechanical controls and roll the gear chain belt with the electromagnet latch lock and release one chain ladder section at a time on the second, third and the final level to unfold the chain ladder completely with the synchronization speed with the elevadoor. **Figure-08: Cybercopter Flyer – Foldable Chain Ladder Folding mode** shows the top view the foldable chain ladder in folding mode. The left drawing shows the first folded level with the round latch lock is pulling out by the gear powered chain belt to hold and roll on the chain ladder bottom section of the ladder when the elevadoor is moving upward. The latch lock is locked and stopped when it is reached to the end; at the same time, the upper level latch lock is pulled out and rolling on the chain ladder of this level by the gear powered chain belt to hold the chain ladder section of this level to its folded position. Similar process for other levels, the right drawing shows

Cybercopter Flyer

the last folding level which is fully folded on the elevadoor base. Note that the elevadoor base would have the cover on top of the base when it is folded to the floor level either manually or automatically.

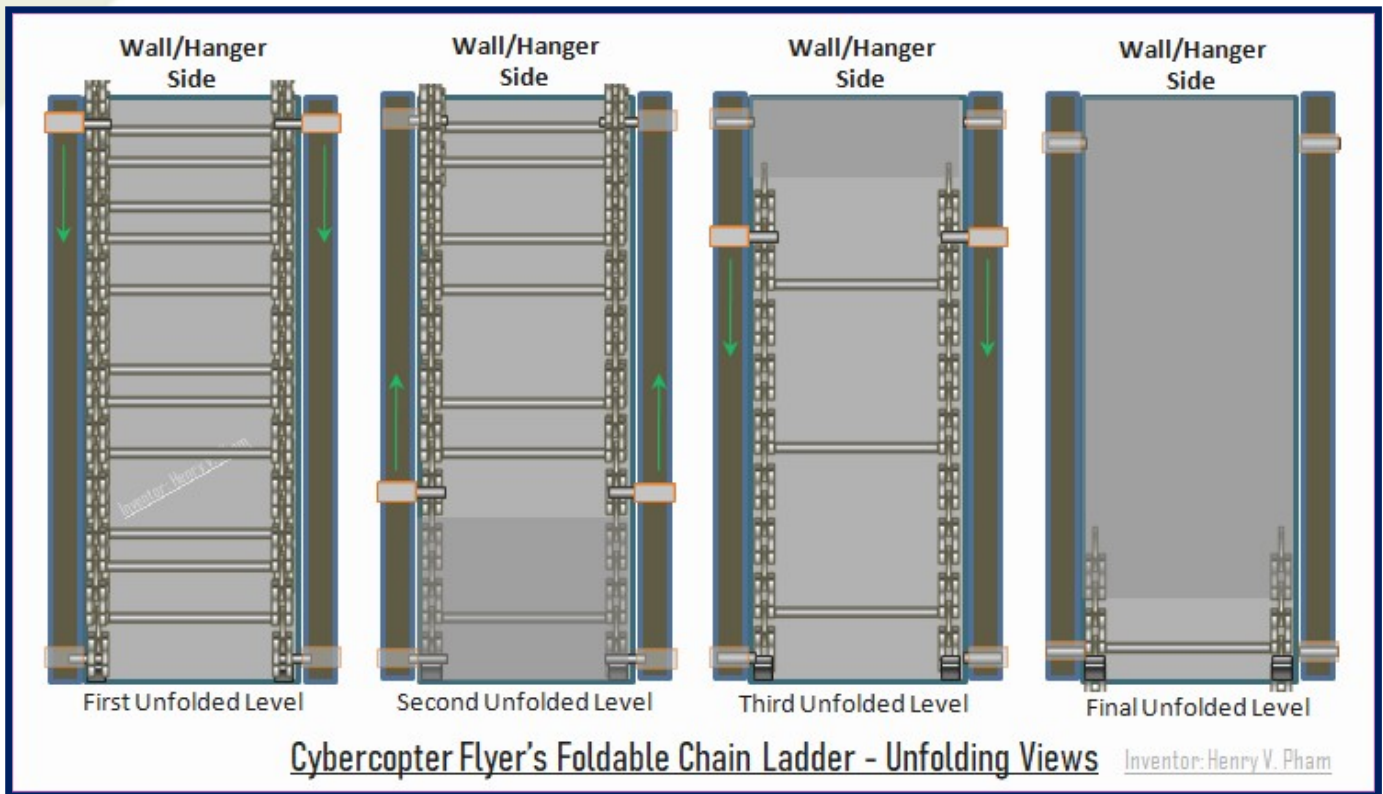

Figure-07: Cybercopter Flyer - Foldable Chain Ladder Unfolding mode

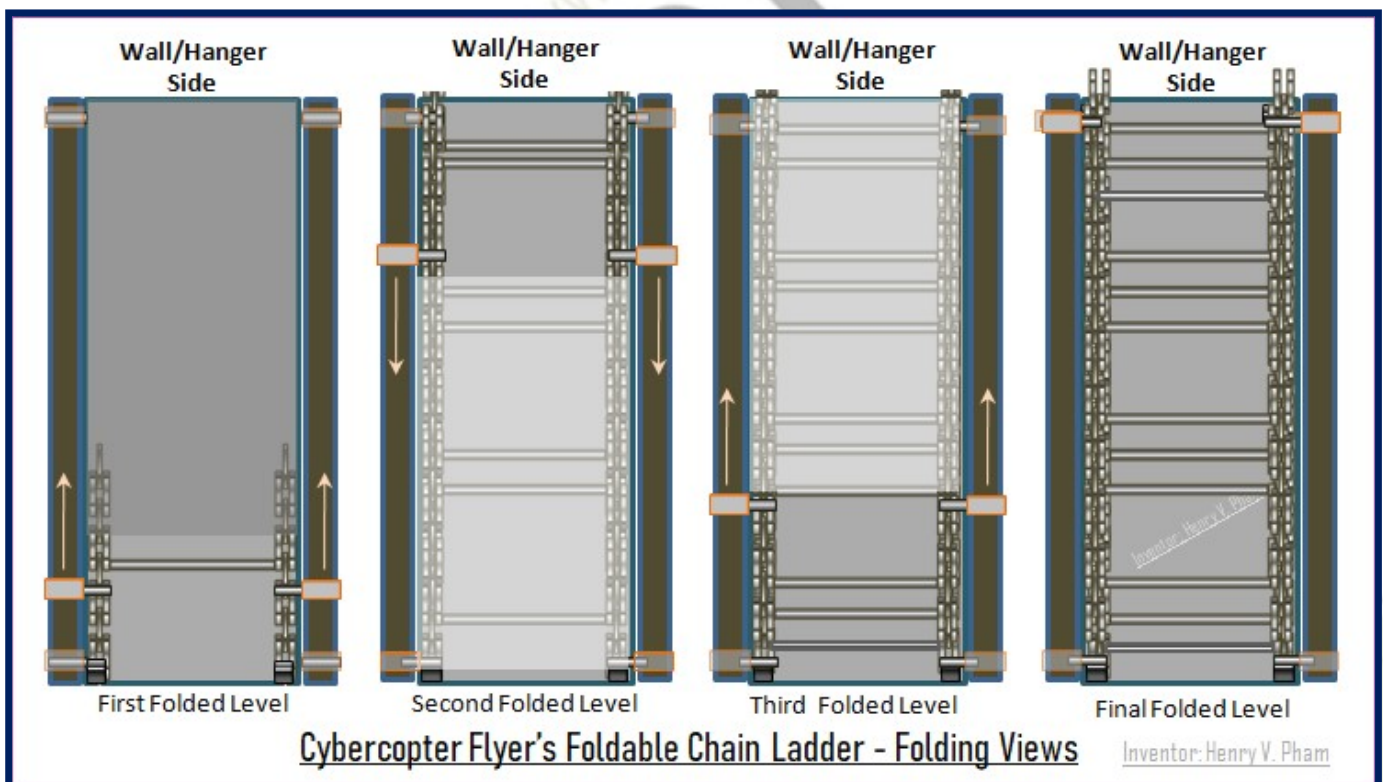

Figure-08: Cybercopter Flyer - Foldable Chain Ladder Folding mode

Cybercopter Flyer

Henry V. Pham

3. Cybercopter Flyer 2-Half Circle Foldable Stair

The 2-half circle foldable stair introduced in this section is another option for the stair in the elevadoor for access and recommended to build with the elevadoor base that has at least 2 meters in diameter. **Figure-09: Cybercopter Flyer - 2-Half Circle Foldable Stair** shows the 2-half circle foldable stair would come with 2 sides to access and showing with 7 steps on each side in this drawing, and recommended to build with standard step dimensions which would reach close to 2 meters high with 1 foot above the ground while landing. The left drawing shows the top view of the stair with 7 steps on each side in 2 different directions; the orange counter clockwise arrow shows the downward direction while the yellow clockwise arrow shows the upward direction for both sides. The floor step on both sides may have a safety rail plus the poles for safety purposes. The drawing on the right side shows the stair when it is unfolded with each piece of dual steps slide and hold each other. **Figure-010: Cybercopter Flyer - 2-Half Circle Foldable Stair Connector Steps** shows how this stair can be folded. The right drawing in this figure shows the side view for the steps which can be connected together and slide to fold; note that a step on one side is built with another step on the other side with the center pole ring connector as a dual step.

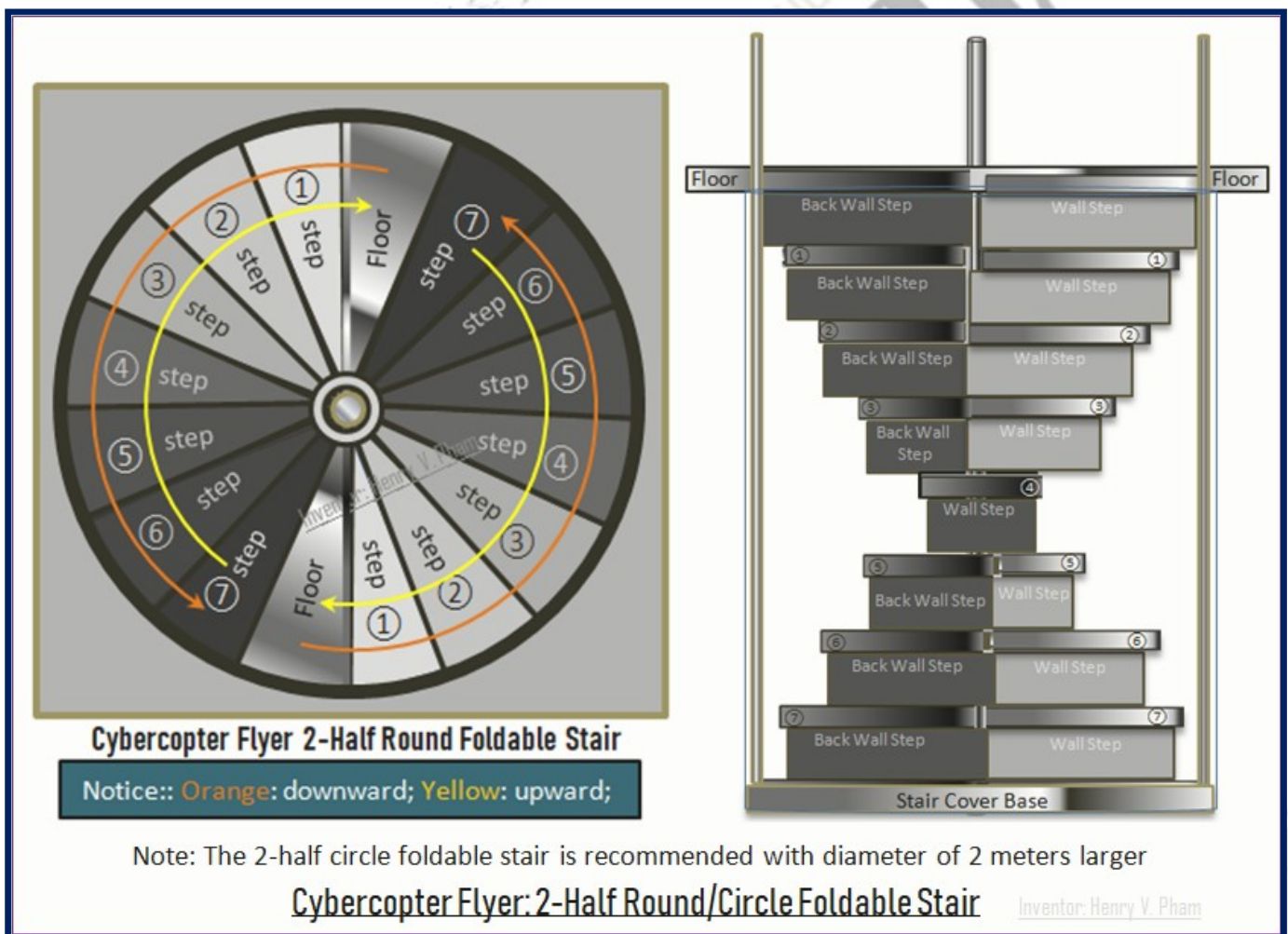

Figure-09: Cybercopter Flyer - 2-Half Circle Foldable Stair

Cybercopter Flyer

The top dual step would have the center pole ring connector higher, and the lower dual step would have the center pole ring connector built lower which are used to connect and stack up on the center pole. Each dual step is recommended to build in box with as shown on the right drawing with strong lightweight material; each dual step is built in revert side, one side with slide knot and the other side with slide slot as shown in 3-D views. The slide knot would slide on the slot of the other dual step, and it is recommended to build with a slide maximum lock bar and slide maximum lock slot which can be used to adjust the maximum slide out of the dual step and lock the knot from slide all the way as shown in purple-blue color bar and red color slot. With the center pole ring connector lower for each dual step and the slide knot and slide slot as shown, the 2-half circle foldable stair can be folded flat to the floor level and unfolded when the elevadoor is pushing downward.

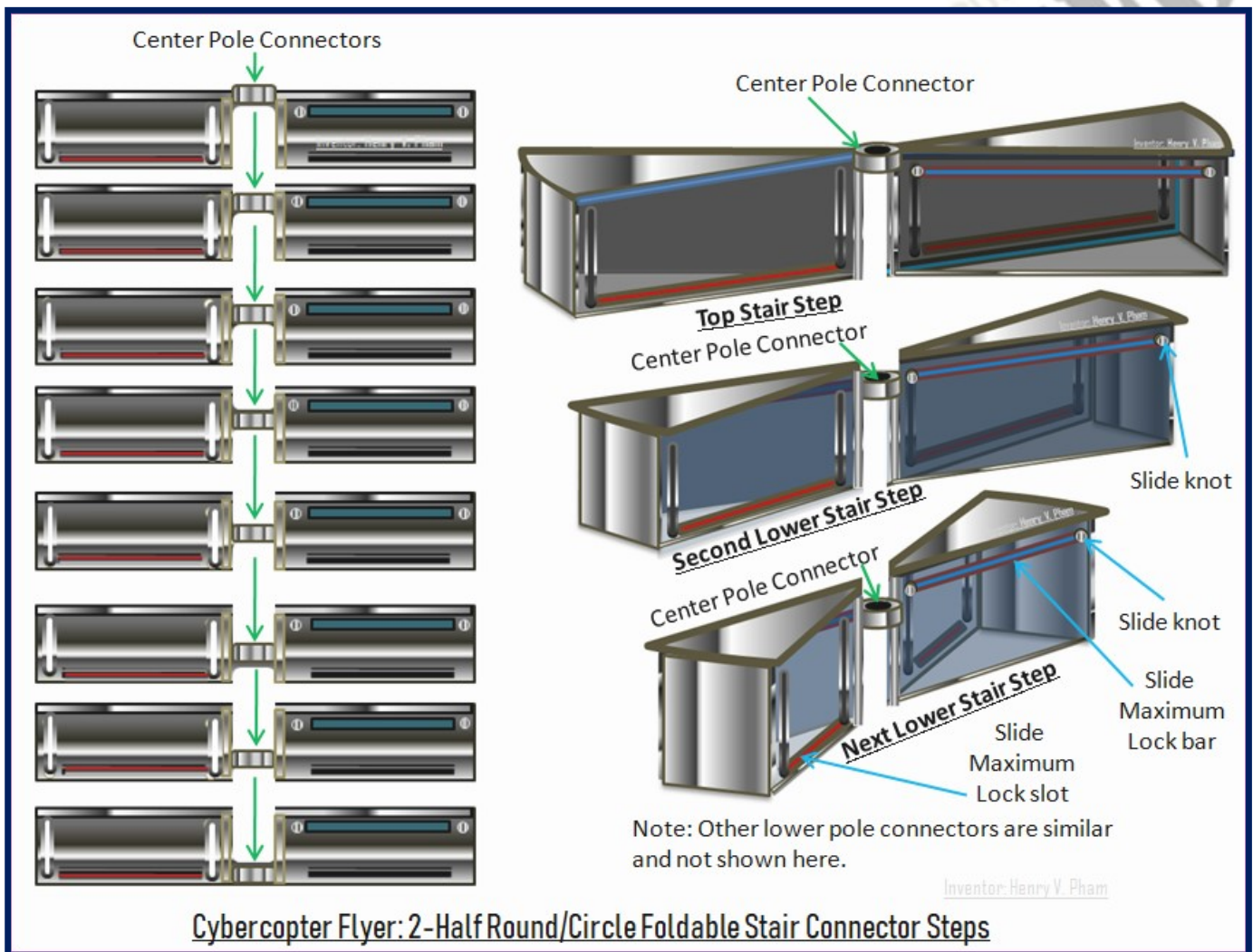

Figure-010: Cybercopter Flyer – 2-Half Circle Foldable Stair Connector Steps

Cybercopter Flyer

4. Cybercopter Flyer Multi-level-Foldable Stair Seats Elevadoor

For large Cybercopter Flyer, the Multi-level Stair Seats Elevadoor can be another great option which can be used for cloud shower, sightseeing, sky diving and rescuing which can be opened during flying or hovering. **Figure-011: Cybercopter Flyer – Multi-level Foldable Round Seats Elevadoor** shows the elevadoor with multi-level round seats or round steps on the elevadoor base. The left drawing shows the top view of the stair with 4 retractable poles around and one center retractable pole with multiple circles which is the round seats or round stairs with the 4 stairways that are used to access into the seats; note that the seats on the rings or brims are not shown in this drawing. The right drawing shows the stair in side view with the safety rail around on the elevadoor base plus the foldable stair rails as an option. The next figures will show how the stair can be folded or unfolded.

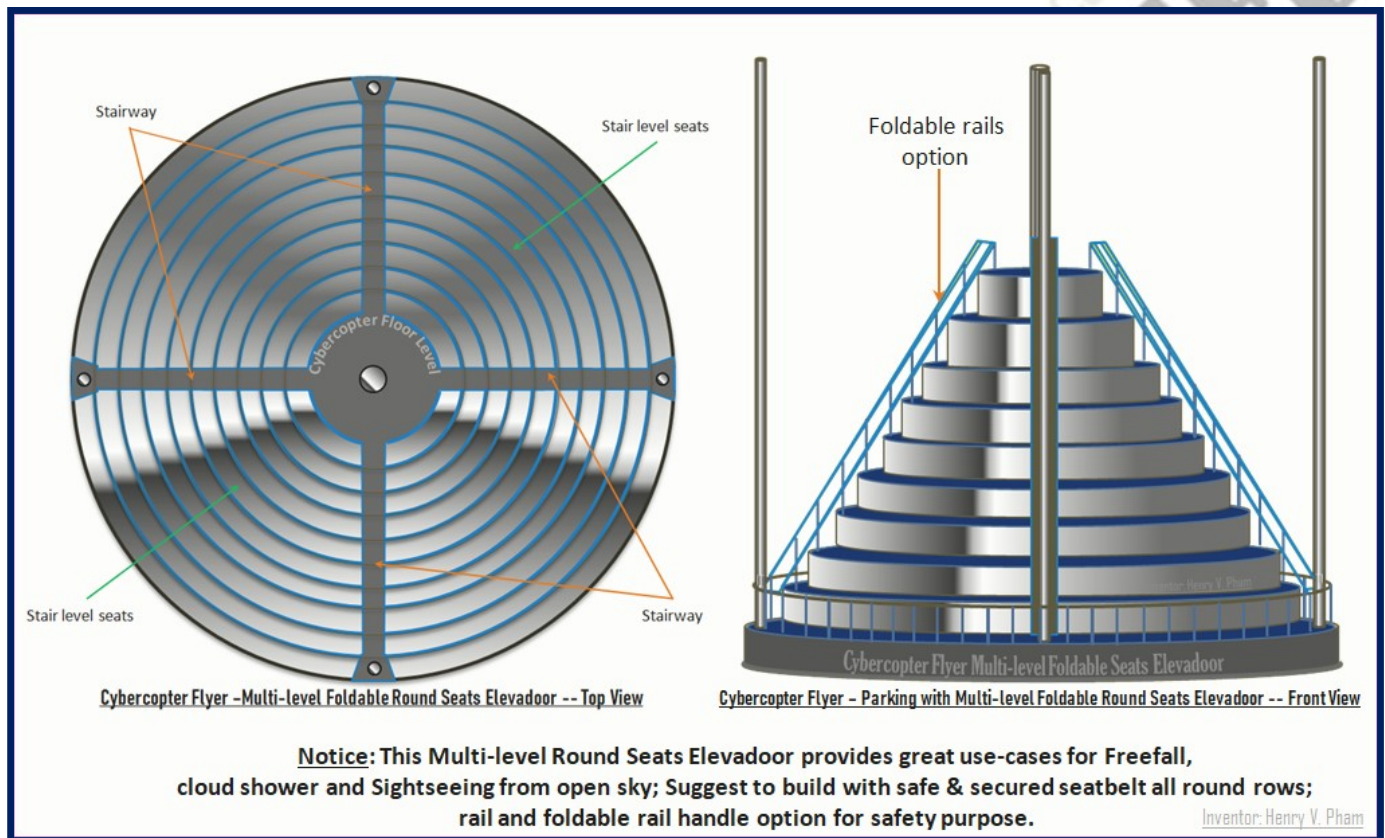

Figure-011: Cybercopter Flyer – Multi-level Foldable Round Seats Elevadoor

The below **Figure-012: Cybercopter Flyer – 3-Level Foldable Round Seats Elevadoor Full-unfold Sample** shows a sample of the 3 round steps with green arrows showing upward for folding and red arrows showing downward for unfolding. The center retractable pole and the 4 retractable poles can be built with either gear rolling or air pushing with rope rally motor mechanism as mentioned in earlier sections. The top inner ring step is fixed on the floor level, and the outer ring steps is stacking on each other that can be slide to fold up and extract out. The lowest ring step is attached and fixed to the elevadoor base; when the elevadoor is rolling up or closing, all the ring steps would be slide on each other to fold either one-by-one or any of them at a time depends on the weight on each ring step. Note that the ring step is recommended to build with strong lightweight material and connected as a ring or brim in circle for a strong bonding shape.

Cybercopter Flyer

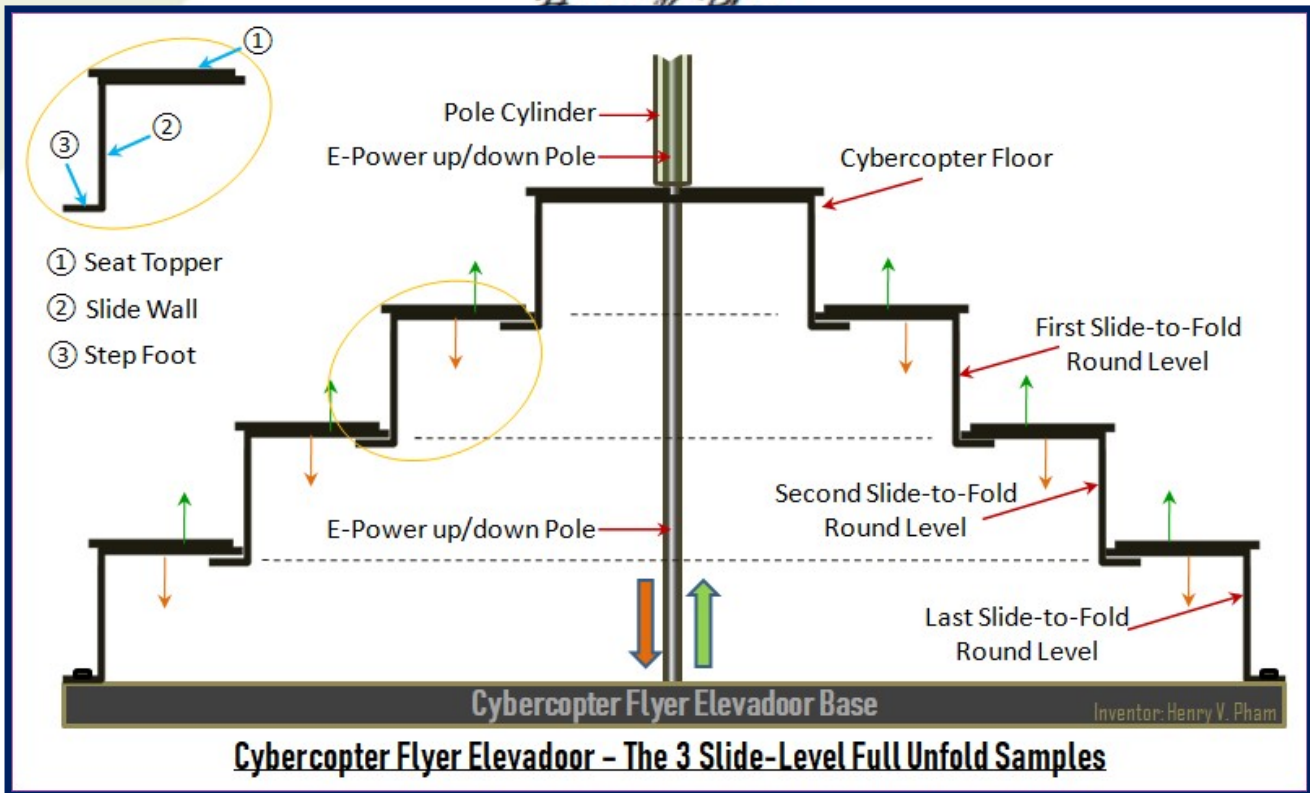

Figure-012: Cybercopter Flyer – 3-Level Foldable Round Seats Elevador Full-unfold Sample

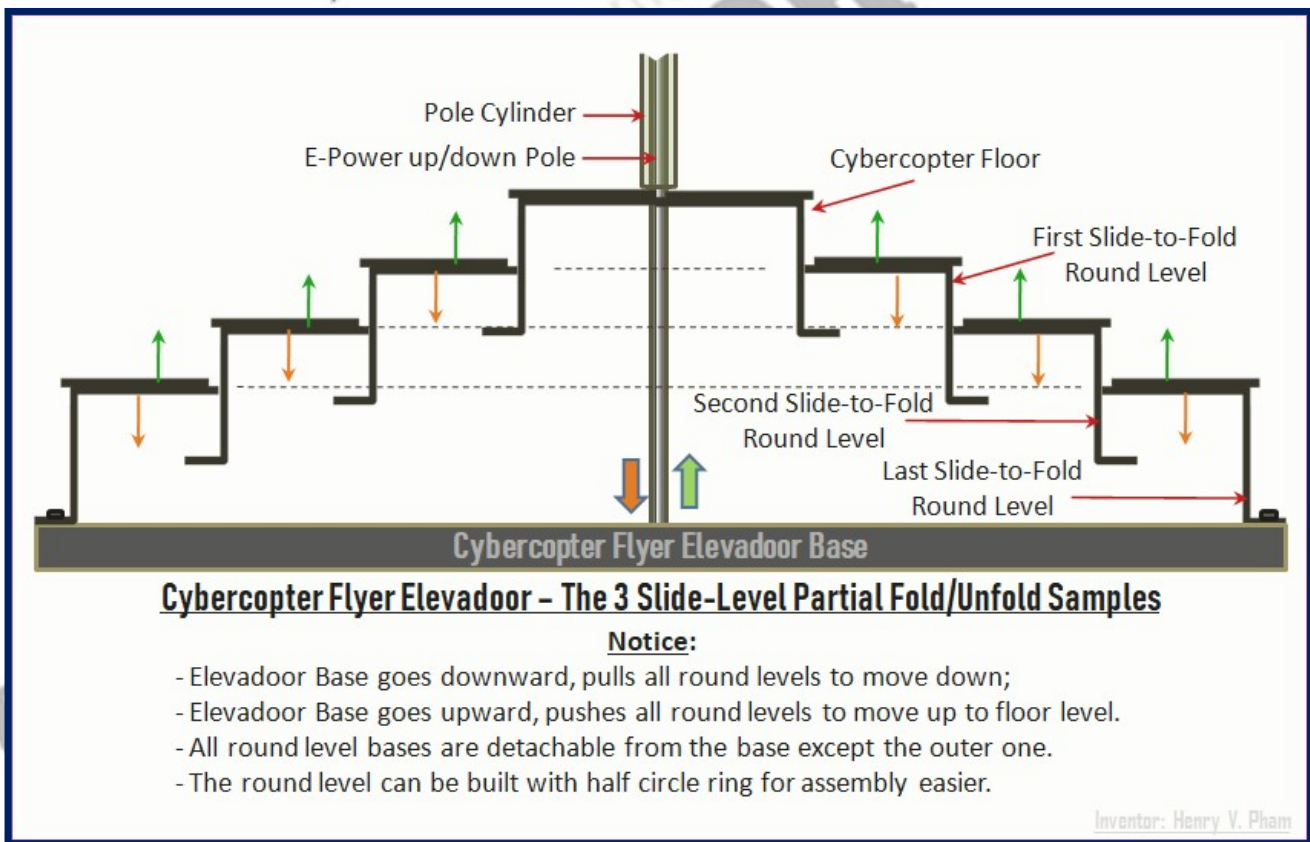

Figure-013: Cybercopter Flyer – 3-Level Foldable Round Seats Elevador Partial Fold/Unfold Sample

Cybercopter Flyer

The above **Figure-013: Cybercopter Flyer – 3-Level Foldable Round Seats Elevadoor Partial Fold/Unfold Sample** shows the multi-level ring steps stair or seats in half open or half close of the elevadoor. When the elevadoor base is pushing downward by the mechanical, all round levels are extracted out; and when the elevadoor base is pulling upward, all round levels are pushed closer to each other to flat on the floor level. The round level can be built with half circle ring for assembly easier and connected together; the round level cutout section was shown in detail yellow round marker in **Figure-012: Cybercopter Flyer – 3-Level Foldable Round Seats Elevadoor Full-unfold Sample** above with Seat Topper, Slide Wall and Step Foot on cross-section of the ring or round step which are built as a round shape. **Figure-014: Cybercopter Flyer – 3-Level Foldable Round Seats Elevadoor Full-folded Sample** shows the stair is folded fully with all ring or round steps flatten on the same surface floor level when the elevadoor is pulled completely to the floor level. Note that the Cybercopter Flyer comes with this stair option would recommend to have at least a guide man to guide the passengers for safety with secured seatbelts and safety use of the rails during the fly.

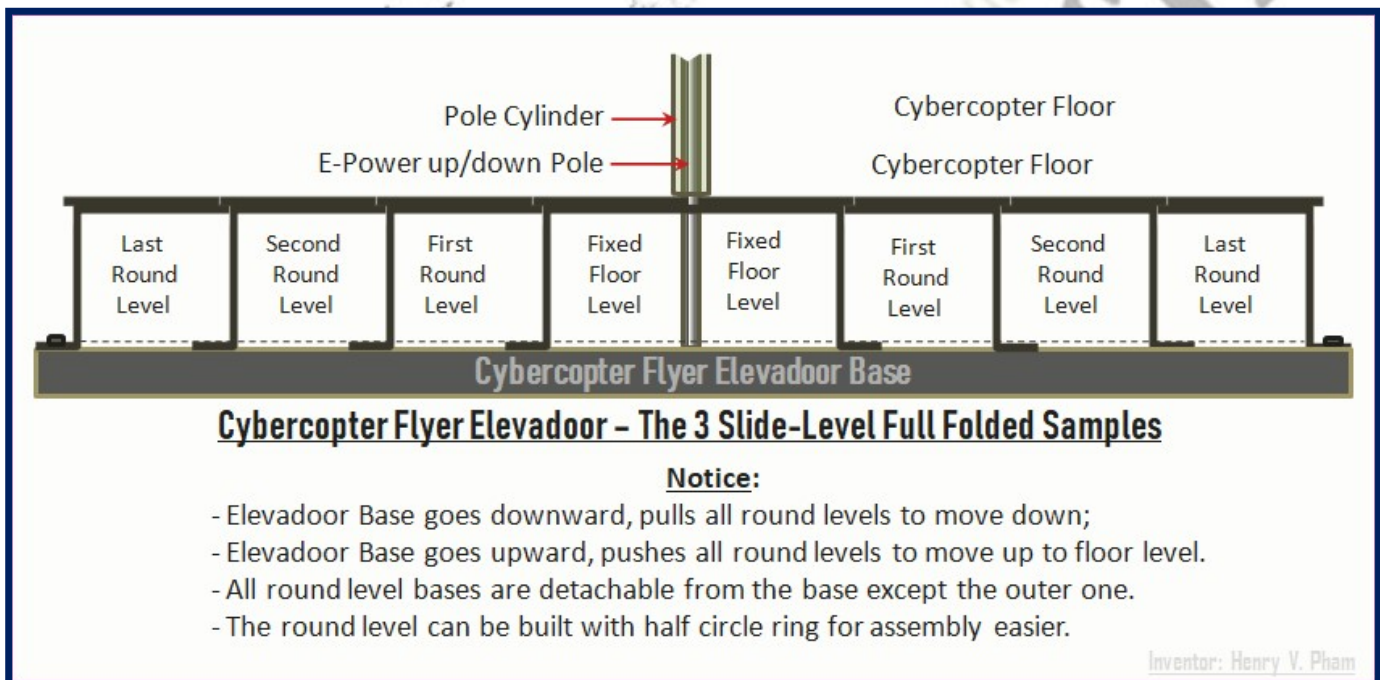

Figure-014: Cybercopter Flyer – 3-Level Foldable Round Seats Elevadoor Full-folded Sample

5. Cybercopter Flyer One Step Self-Foldable Elevator

The One Step Elevator or One Step Escalator is the compact design and is useful and convenient with battery power operated for small space environment which was already mentioned in my other inventions. The One Step Self-Foldable Elevator is introduced into this invention as a compact and convenient design for personal elevator for Cybercopter Flyer, which can be used standalone by hooking it on the flyer floor level to access or on the bottom of the flyer to access the luggage storage or other utilities and accessories. **Figure-015: One Step Self-Foldable Elevator** shows the fully unfolded views of the one-step self-foldable elevator sample. The left drawing shows the self-foldable elevator in side view with 5 extracted slide boards on the front of the elevator, the extractable gear bars on the back of the elevator, and the one-step attached to the self-foldable elevator box. The self-foldable box would come with 5 gear

Cybercopter Flyer

motors on each side and one for each gear-side step board, and 3 gear motors one each side on the back of the elevator. The middle drawing shows the front view of self-foldable elevator with gear bar on the side of each board which is used to roll up or down by the gear motors. The elevator is recommended to build with strong lightweight material, and the step board is recommended to build as a board without open space to prevent from foot or hand stuck for safety purposes. The right drawing shows the one-step self-foldable elevator in back view with semitransparent step boards and the back extractable gear bars with the gear motors in the elevator box to keep the weight balance while the elevator is moving up or down since this is the standalone compact elevator which might hook only one side to the wall or the flyer floor level without touching or slide on anything else either on the side or on the back of the elevator.

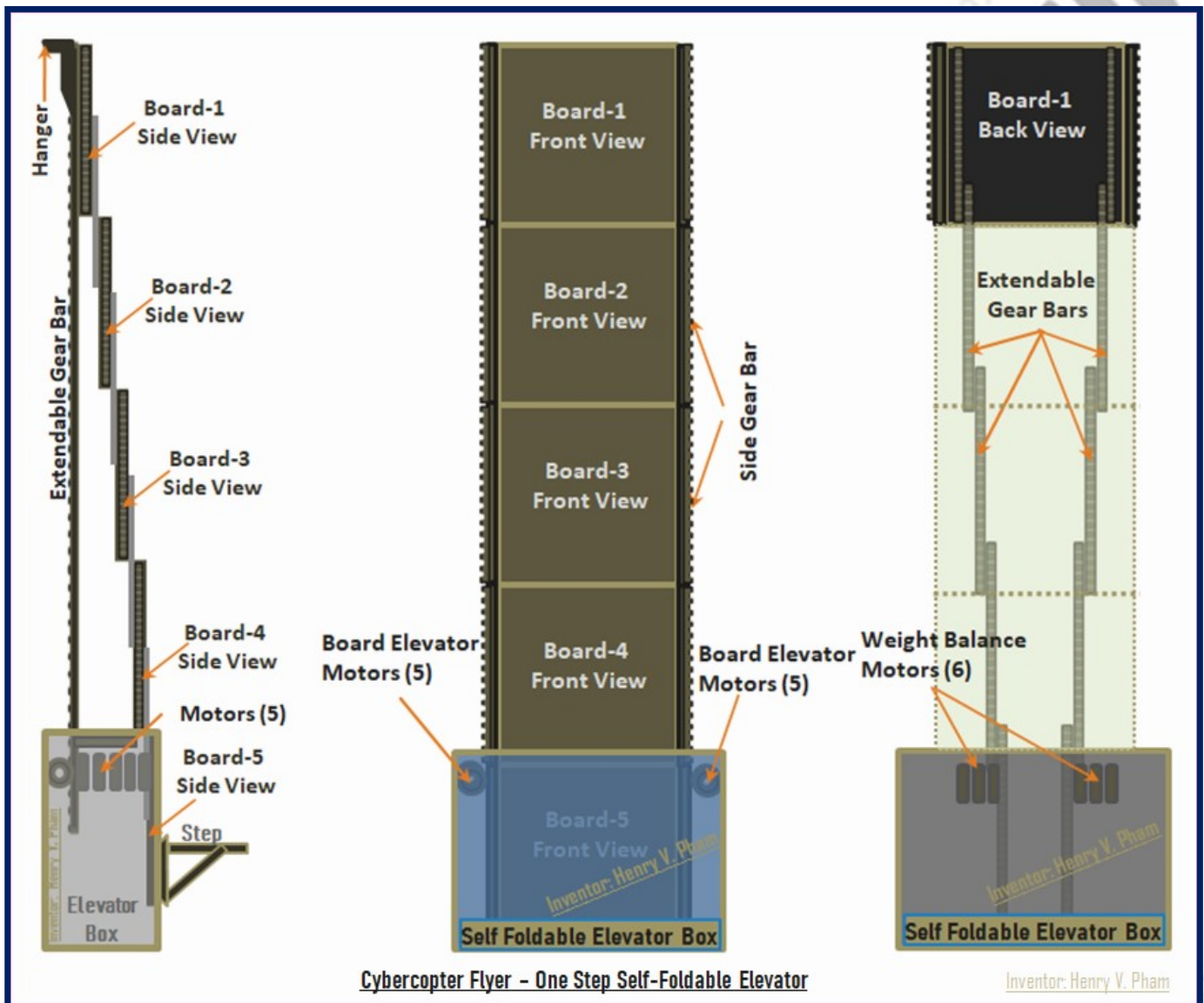

Cybercopter Flyer - One Step Self-Foldable Elevator

Inventor: Henry V. Pham

Figure-015: One Step Self-Foldable Elevator

Cybercopter Flyer

The below **Figure-016: One Step Self-Foldable Elevator 2 Slide Gear Boards Sample** shows detail views of the one-step elevator. The step board would come with gear bar on both sides which can be built with the gear bar slide into the slot base on the board and screw on the base or can be built-in with the board. The front or top surface of the step board would have 2 slots for the upper step board's slide bars to slide in; the back surface of the step board would have 2 slide bars to slide on the front or top surface of the step board's slots. The bottom right drawing shows the 2 step boards on top each other with the slide bars on the slots of the lower board.

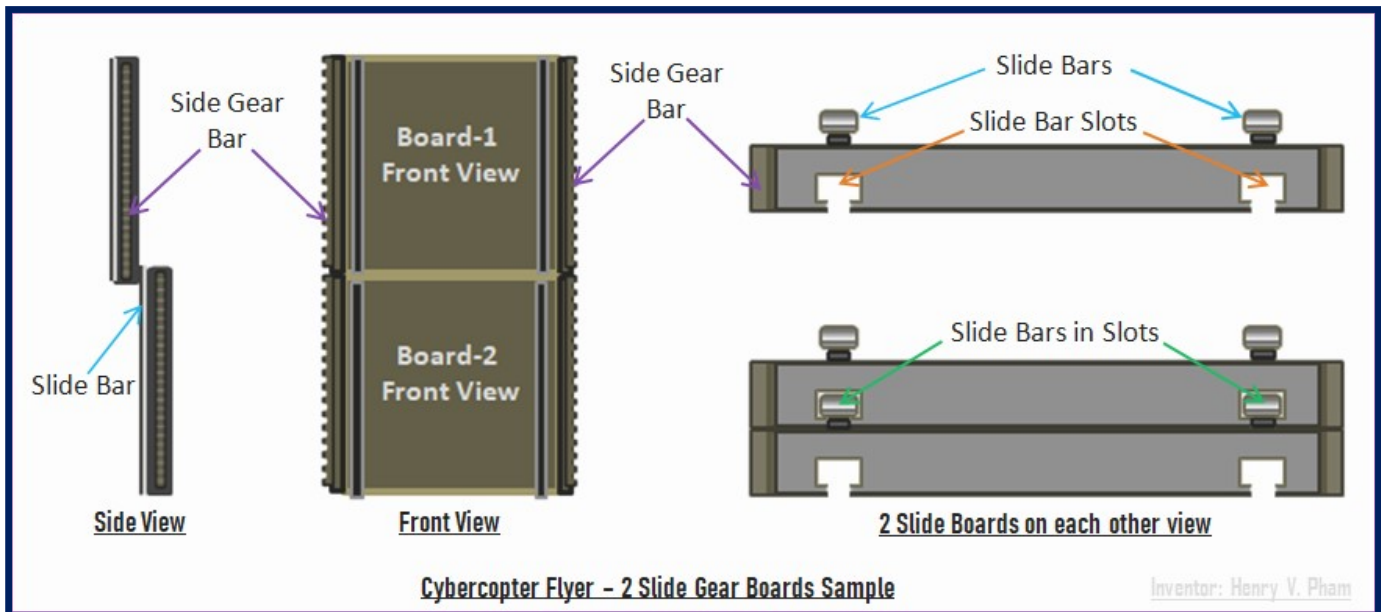

Figure-016: One Step Self-Foldable Elevator 2 Slide Gear Boards Sample

The below **Figure-017: One Step Self-Foldable Elevator 2 Slide Gear Boards Operating Sample** shows one-step elevator with detail of the step board and the slide bar and slot which is similar to the **Figure-05: Cybercopter Flyer – Elevadoor Base & Slide-Foldable Ladder Details** and described in the earlier section.

The foldable upper board and lower board are shown in the figure with the labels 's' is the width of the slide bar open slot; 'w₁' is the larger width of the slide bar and considered as a lock bolt; 'w₂' is the smaller width of the slide bar. The slide lock has the width equals to 'w₂' to hold and lock the slide bar bolt ('w₁' > 'w₂'). The upper slide bar is recommended with the width of 1¼ to 2 inches, and the difference between 'w₂' and 'w₁' is recommended about ½ to 1 inch; the open slide slot 's' is recommended with at least 3/8 inch. The width of the stair is recommended with at least 15 inches or a small standard size of a ladder.

The slide bar bolt is used as a lock when the board is extracted completely; the bottom drawing in this figure shows the 2 gear-side boards with one on top the other to the maximum extracted position which shows the bar bolt is locked at the ending slot of the lower board.

Cybercopter Flyer

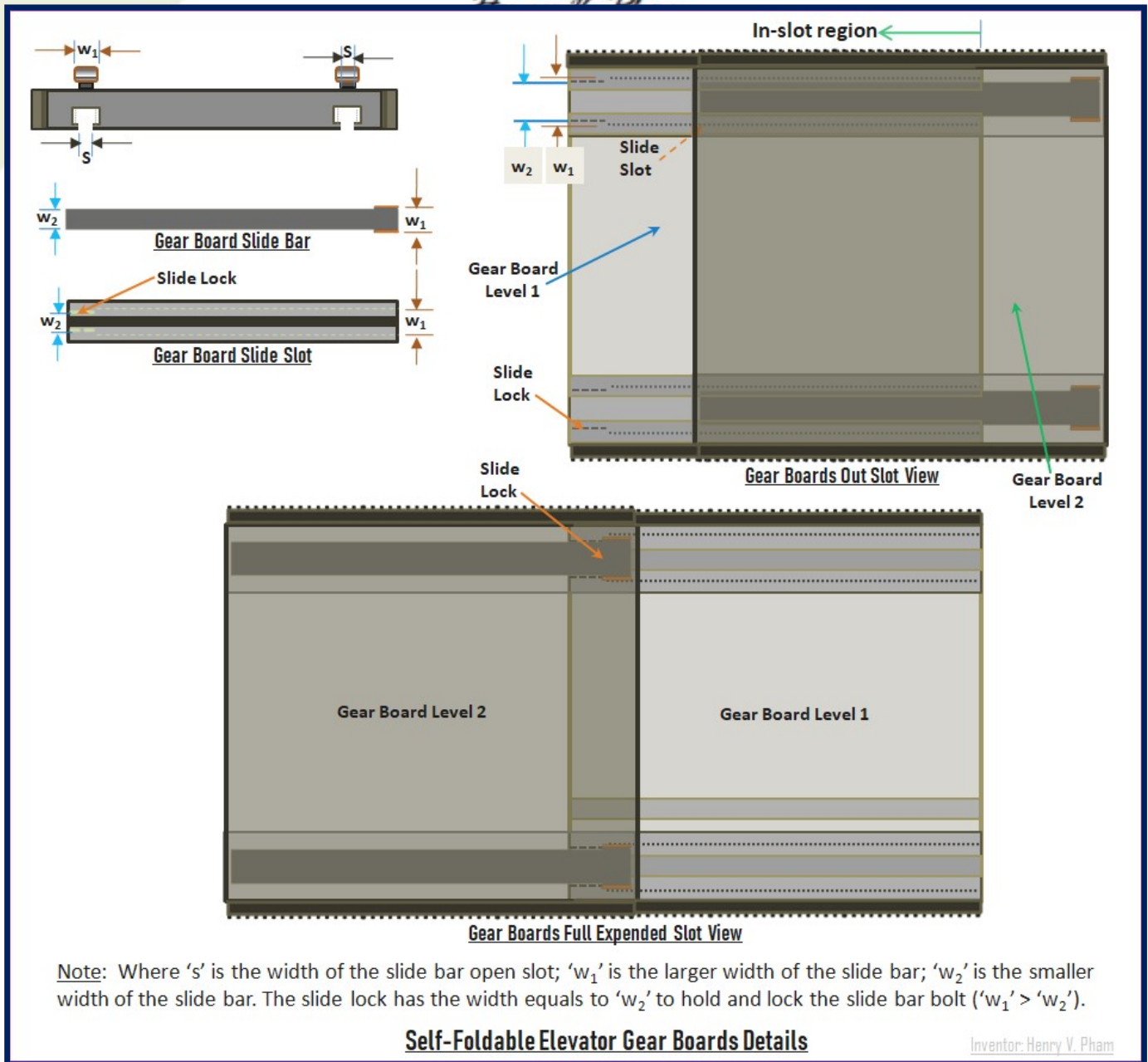

Figure-017: One Step Self-Foldable Elevator 2 Slide Gear Boards Operating Sample

The below **Figure-018: One Step Self-Foldable Elevator Dual Side Slots Gear Bars Sample** shows the back gear bars detail of the one-step elevator. The gear bars can come with many sections and connected together as long as the total extracted length is the length of the one-step elevator fully unfolded; and the gears and motors are needed to be synchronized with the gear motors of the gear-side step board for the timing and distance when the stair is folded or unfolded. The gear bar would come with both sides with slide slots and the slide locks (bolts) as shown; when the gear bar moving down, the slide lock bolt will be hold by the ending slot and the slide lock bolt would be built alternately one on top of a side, then one of bottom of the other side. The slide slot is recommended with at least 3/8 inch in open slide and 1/2 inch width and 3/8 inch deep that enough to hold the elevator with one and another of the slide bars.

Cybercopter Flyer

Henry V. Pham

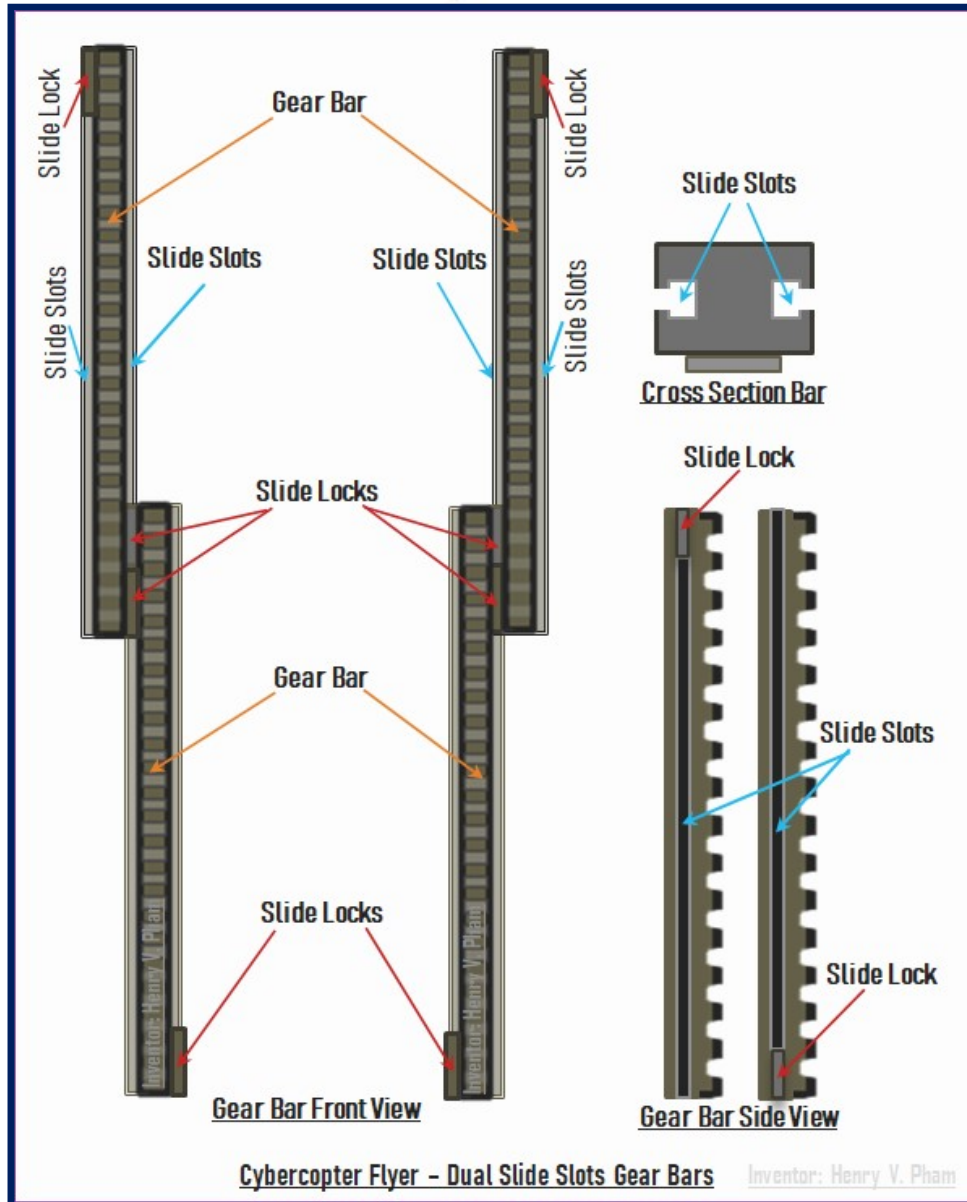

Figure-018: One Step Self-Foldable Elevator Dual Side Slots Gear Bars Sample

The one-step self-foldable elevator would have a controller box which has the gear motors and latch locks to roll the gear slide bars or boards up and down. Figure-019: One Step Self-Foldable Elevator Controller Box shows. The left drawing shows the control box in side view with 5 gear board motors one each side of the box, and each pair of the gear motor would control each gear board. When one gear board is moved out of the box, the other gear board would be in turn to continue rolling the stair since all the gear boards are connected together and gear bar from one to another are overlapped each other and independently from each other when one is out or completely in of the control box. Note that all gear motors are turning at the same time to simplify the space; and when the gear board is completely inside the control box, the electromagnet lock would be triggered to lock the gear board when the gear is completely off from the

Cybercopter Flyer

gear motor, and when the gear board is outside the control box, the electromagnet lock of the next board would be triggered to release the gear board and ready for the next gear board to move out.

The back balance gear bars also work similar to the gear board mechanism; the right drawing shows the back gear mechanical that control box rolls the side gear bars up and down. There are 3 sets of side gear bars, and each set is controlled by a pair gear motor as shown. Similar with the gear board mechanism, when the gear bar is completely inside the control box, the electromagnet lock would be triggered to lock the gear bar when the gear is completely off from the gear motor, and when the gear bar is outside the control box, the electromagnet lock of the next bar would be triggered to release the gear bar and ready for the next gear bar to move out. Note that the electromagnet lock device can come with round or square latch to lock the gear bars.

The Cybercopter Flyer would be provided with one of these foldable ladder or foldable stair, however, a rope ladder with hanger is recommended to have for the flyer for personal use when needed.

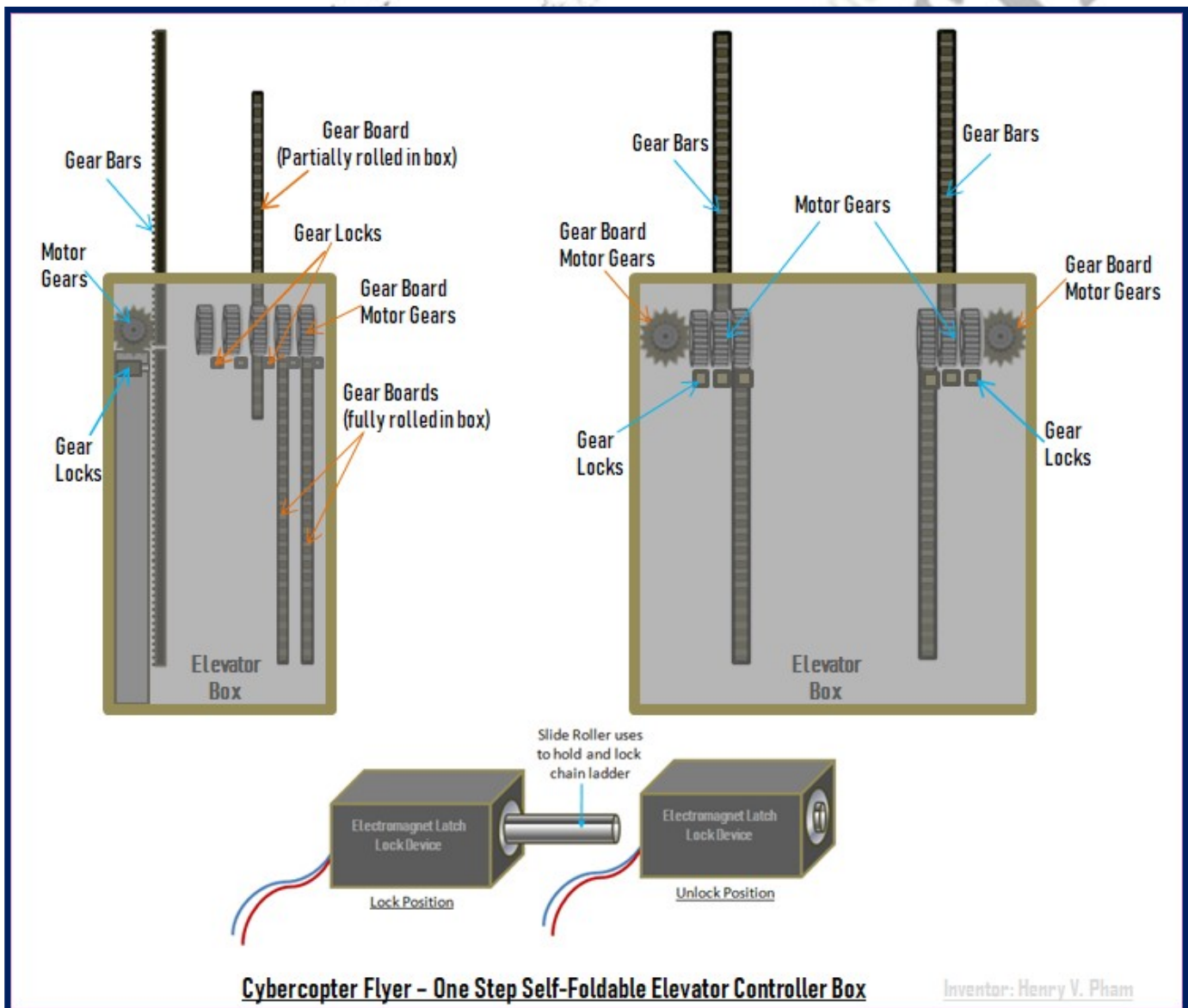

Figure-019: One Step Self-Foldable Elevator Controller Box

Cybercopter Flyer

P. Cybercopter Flyer Luggage & Storage

The Cybercopter Flyer with circle shape and the best space to build luggage and storage is at the bottom of the flyer within the 2 side Standiers which was mentioned in the earlier section and shown the locations in [Figure-D1: Cybercopter Flyer - Bottom view](#). The common luggage and storage are shown in the below [Figure-P1: Cybercopter Flyer Luggage & Storage](#) which is the best fit for this flyer platform in common regular dimensions for personal and private flyers; note that for big size Cybercopter Flyers, the luggage and storage could be in larger forms and different shapes that are acceptable with safety and security compliances. The top left drawing shows the luggage and storage in angle open storage shape and in rectangle box shape next to each other; the reason to have the rectangle box shape storage right next ahead of the angle open storage is to have room to open the angle open storage, which means that the rectangle box is needed to open first before the angle open storage. The top right drawing shows the angle storage with half-way open; this kind of storage is common use everywhere and no need to tell much in details.

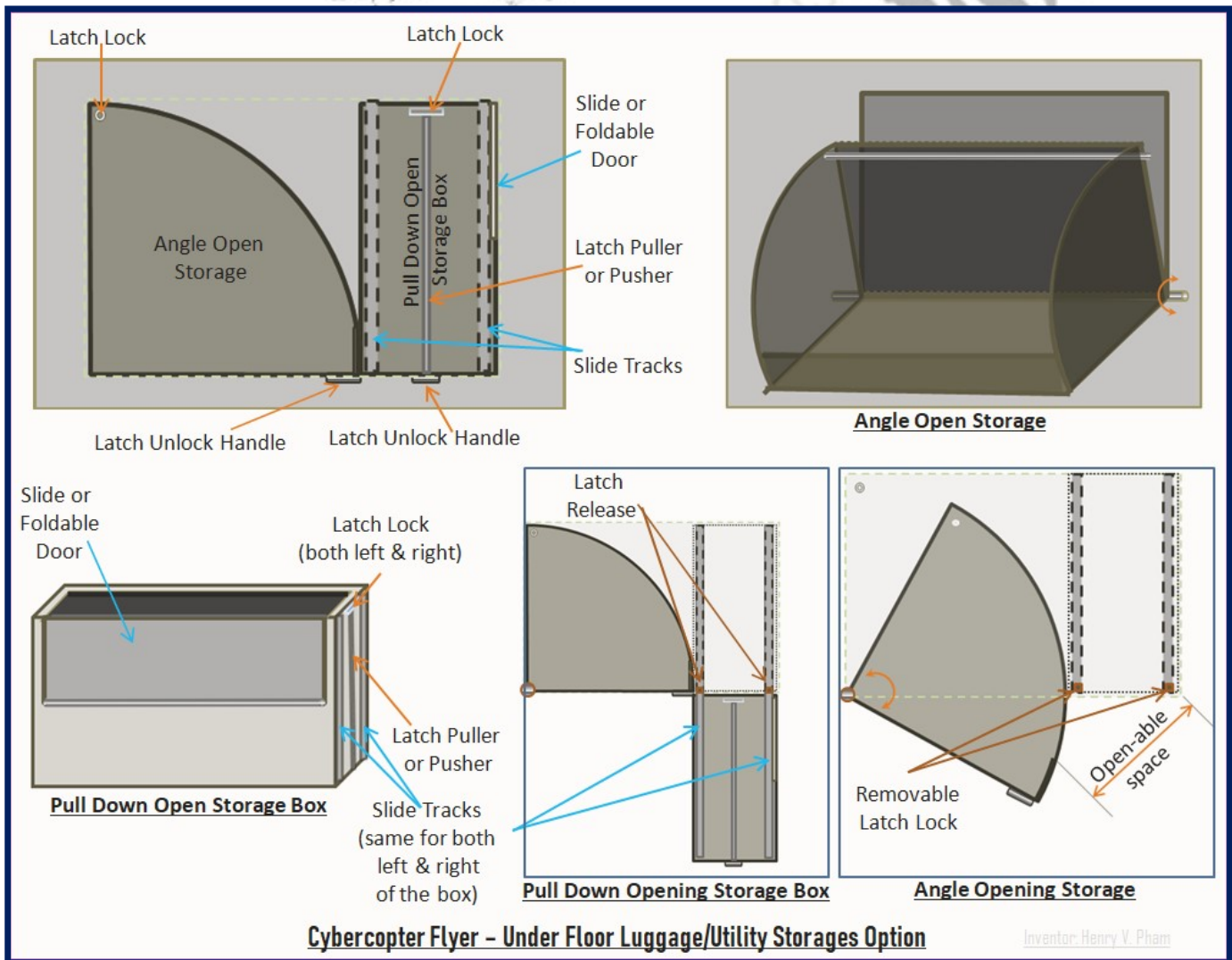

Figure-P1: Cybercopter Flyer Luggage & Storage

Cybercopter Flyer

The bottom left drawing shows the storage box in rectangle block shape which come with a slide or foldable door which can be opened when pulling down lower by the Latch Lock handle. When the Latch Lock/Unlock handle is pulled down, the latch lock on top will be released as shown on the top left drawing; this works similar to the drawers. When the storage box is pushed all the way up into its fit position, the latch lock on top should be latched and lock/hold the storage box; the latch lock would come with the spring to lock when pushing the storage box in, and the latch lock would be open when the Latch Unlock Handle is pulled down. The storage box is recommended to build with latch release to remove the storage box completely out of its rack to have more room to open the angle open storage. The bottom right drawing shows the storage box shape is completely removed and the angle open storage can be easily opened. Note that this is the compact design for the small Cybercopter Flyer which does not have much space to build the storages; of course, it would be easier to build any storage shapes if the space is allowed.

Q. Cybercopter Turbofan/Turbojet Engines

For perfect world of air transportation with turbofan, turbojet or any other advanced engines, it is recommended to have the standard engine modules to support plug-to-fly technology for the great future of our air transportation. The idea to have the standard engine modules is that one manufacture can focus to build just on turbofan, turbojet or other types of engines, and other companies or manufactures can build their own airplanes, their own aircrafts or their own Cybercopter Flyers and use any of the standard engines as the plug-and-play modules with compatible in standard controller for their own flyers. The standard engines can be built in certain standard dimensions with maximum and minimum power of thrust with the standard controllers, and the other companies or manufactures can use the engines that fit their own flyers. The world is higher demand of air transportation for faster traveling around the world or city to city personally or privately; the standard engine modules recommendation would be great for our future of air transportation services.

Figure-Q1: Cybercopter Flyer Engines Samples below shows a sample view of turbofan and turbojet engines, the engines with multiple fans. The top drawing shows a sample of turbofan engine with multiple fans which spinning around their own stator with multiple blade levels that would provide more thrust from pulling more air intake into the engine and exhaust quicker to the thruster to produce more propulsion forces. The same principle of air intake, the turbojet engine pulls the air intake into the engine with compressor and burns the fuel to generate more air propulsion power thrust to push the flyer moving forward faster. However, the jet engines require fuel which is not convenient for personal use; the turbofan engines can use only electrical power which is the best fit for small flyers, and the Cybercopter Flyer with solar power is great and perfect for our small air transportation services.

The engines would have nozzle or thruster connecting with the engine neck or nozzle neck which is used tilt the engine thrust with the thruster tilter. The vertical thrust engines of the Cybercopter Flyer are required to have capability to tilt the thrust to move forward faster and slow down quicker and use for 3 engines when one burnt out. The thruster tilter can adjust the nozzle neck to change the thrust to support this requirement; the next section will introduce several types of engine thruster tilters.

Cybercopter Flyer

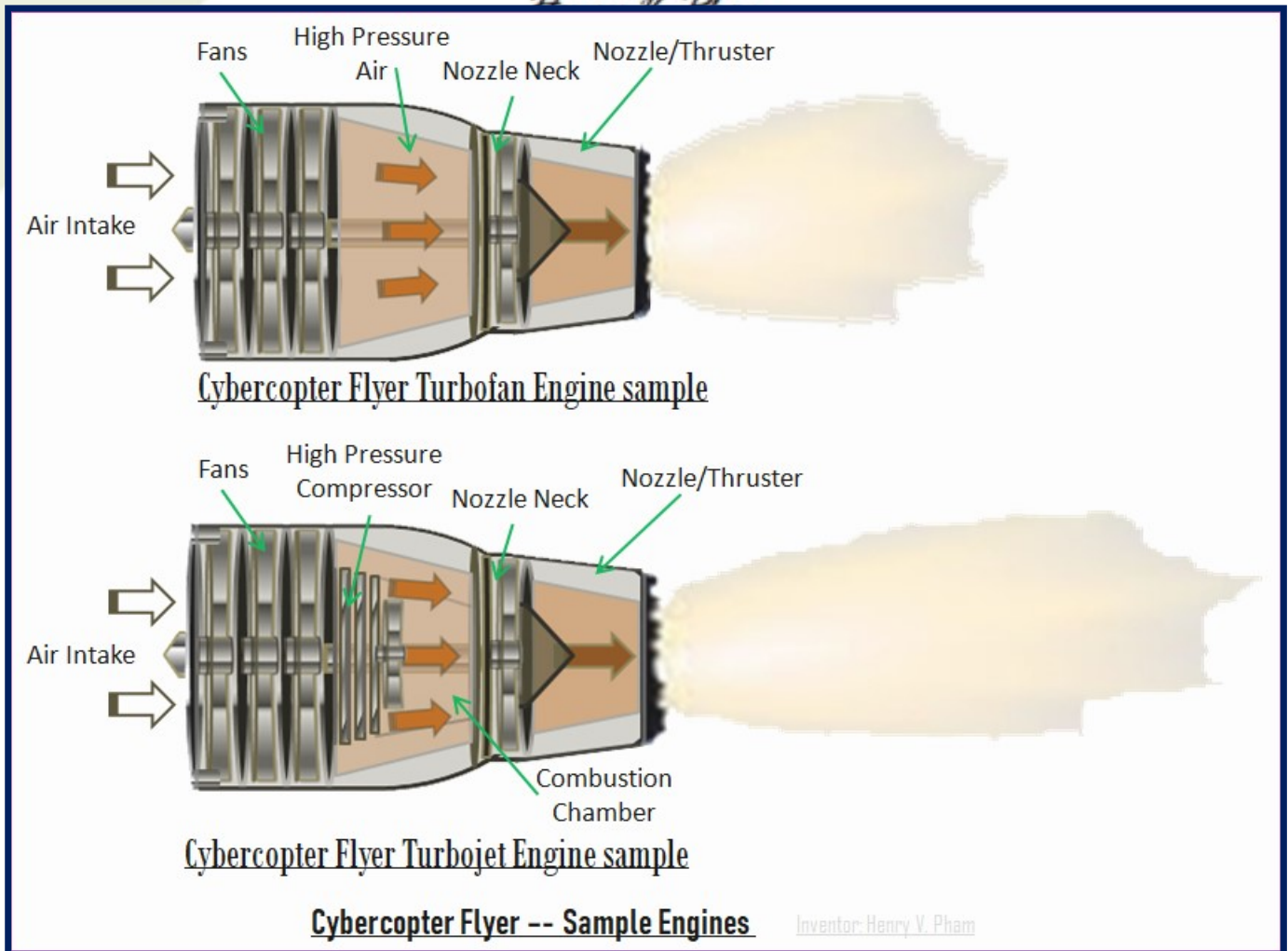

Figure-Q1: Cybercopter Flyer Engines Samples

R. The Engines Thruster Tilters

1. The Square Engine Thruster Tilter

The 4-ways engine tilter or the square engine tilter is the most simplest engine tilter, and it is shown in the Figure-R1: Cybercopter Flyer Simple Square Engines Tilter below. This figure shows the square engine thruster tilter with 2 planes; the engine tail or thruster come with 2 bars attached to it, and these 2 bars are moving along their track on their own plane. The plane-1 is shown horizontally and the thruster and the 2 attached vertical bars moving along the horizontal plane-1 for the left and right tilting directions. The plane-2 is shown vertically and the thruster and the 2 attached horizontal bars moving along the vertical plane-2 for the upward and downward tilting directions. The mechanical would have 2 motors, one for each plane to slide left and right on the plane-1 and slide up and down on the plane-2. The top right drawing shows the engine thruster tilter sliding on the plane-1 within the guard bars on the tracks with straight moving. The bottom right drawing shows the engine thruster tilter sliding on the plane-2 within the guard bars on the tracks with straight moving. The thruster tilter would move straight to the center before switching direction in 90° degrees angle.

Cybercopter Flyer

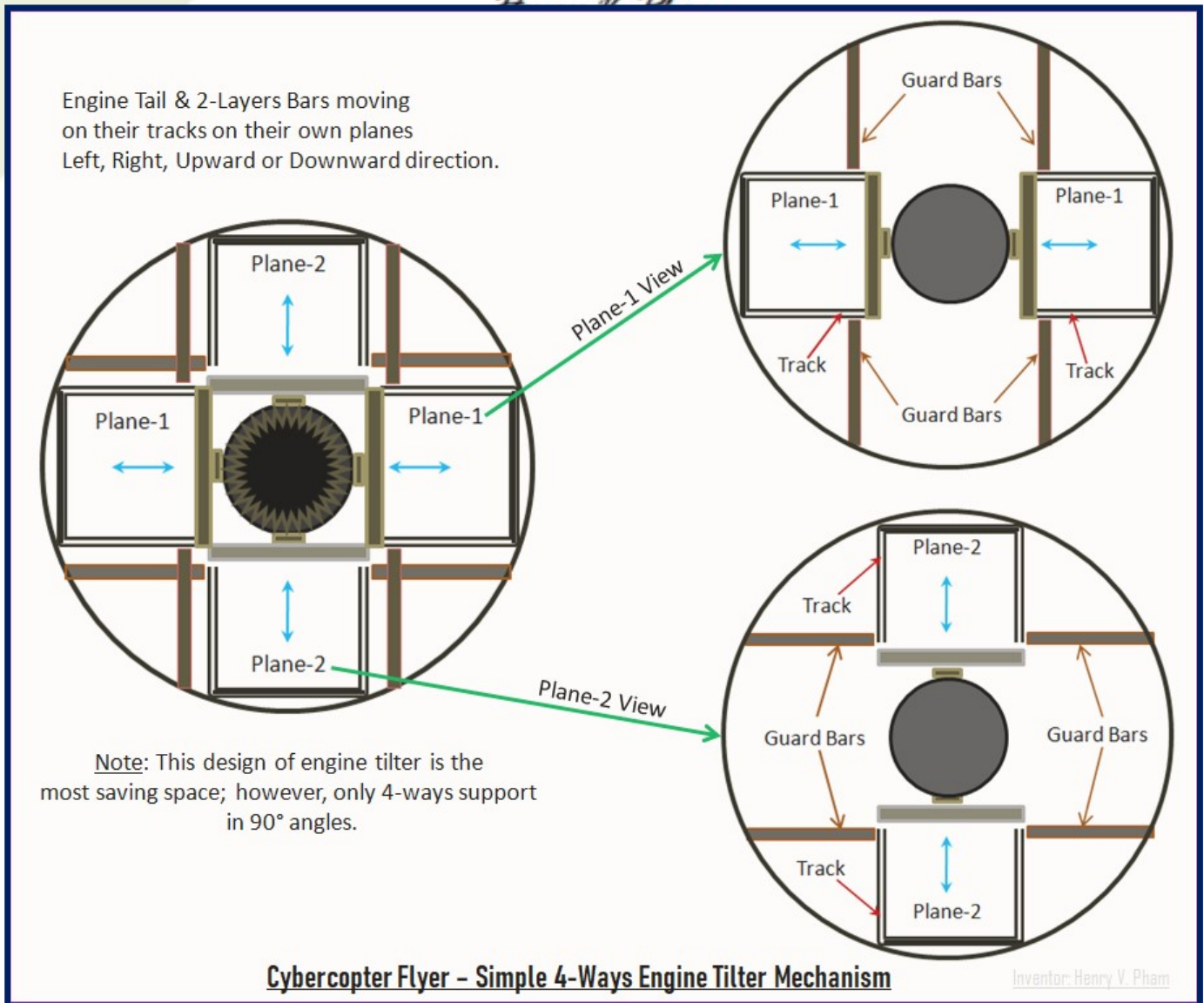

Figure-R1: Cybercopter Flyer Simple Square Engines Tilter

Figure-R2: Cybercopter Flyer Simple Square Engines Tilter Directions shows the 4-ways thruster tilter positions in combination of the 2 planes view. The neutral position is shown at the center; the 2-bars attached to the thruster on each plane are aligned right at the center and ready for any one of the 4 directions of tilting. The top left drawing shows the thruster tilter moving to the left with the 2-bars attached to the thruster on the horizontal plane-1 sliding on their tracks. The top right drawing shows the thruster tilter moving to the right with the 2-bars attached to the thruster on the horizontal plane-1 sliding on their own tracks. The bottom left drawing shows the thruster tilter moving to the top with the 2-bars attached to the thruster on the vertical plane-2 sliding on their own tracks. The bottom right drawing shows the thruster tilter moving to the bottom with the 2-bars attached to the thruster on the vertical plane-2 sliding on their own tracks. Note that the motors for thruster tilters are not showing detail in this invention document which is depended on the space available of the flyer around the engines; however, rope or cable with rally motors can be used in this case to pull the thruster tilter supporters.

Cybercopter Flyer

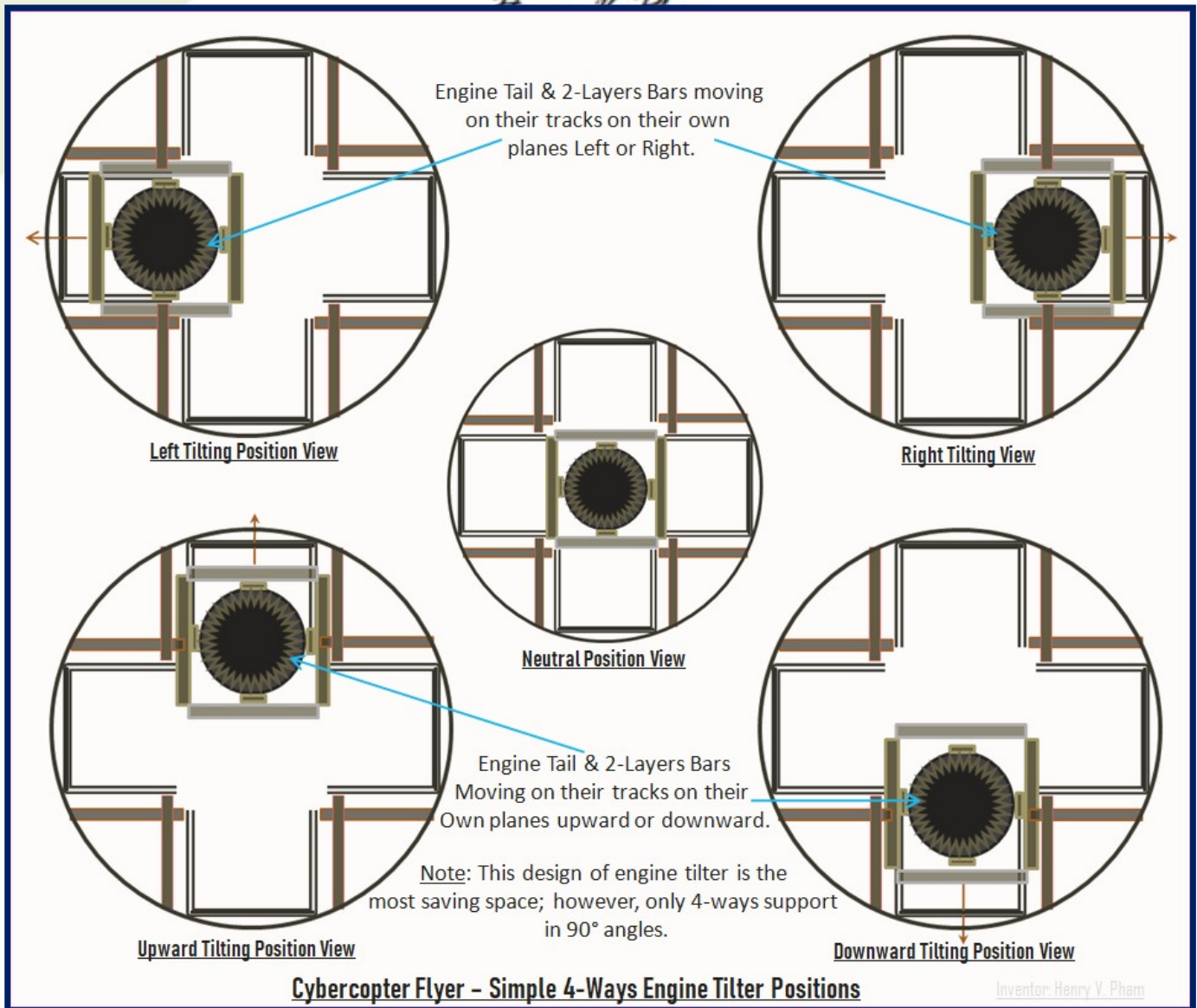

Figure-R2: Cybercopter Flyer Simple Square Engines Tilter Directions

2. The Hexagon Engine Thruster Tilter

With higher demand of air transportation in the future, engine thruster tilters are also needed to be more tilting angles or directions with solid tilting technology. The Hexagon Engine Thruster Tilter is introduced with 6-ways engine tilting directions in hexagon shape. **Figure-R3: Cybercopter Flyer Hexagon Engines Tilters View 1** shows the thruster from the initial position back to the neutral position after the first move downward direction. There are 6-ways or 6-lanes shown in white color; note that the plane-1 is shown in white color open lanes, and the plane-2 is covered with light gray rectangle with light blue dash border around, and the pole dot at center with red border is the pole position; the pole is the corner of the triangle which will be shown more detail in later drawings. This figure shows the P1S1 (Plane-1 & Slider-1) starts holding the pole which is shown on the top right drawing, then pushing downward as shown on the

Cybercopter Flyer

bottom left drawing, then finally return back to the neutral position with the robot hand still holding the pole; this is one complete move pushing downward of P1S1.

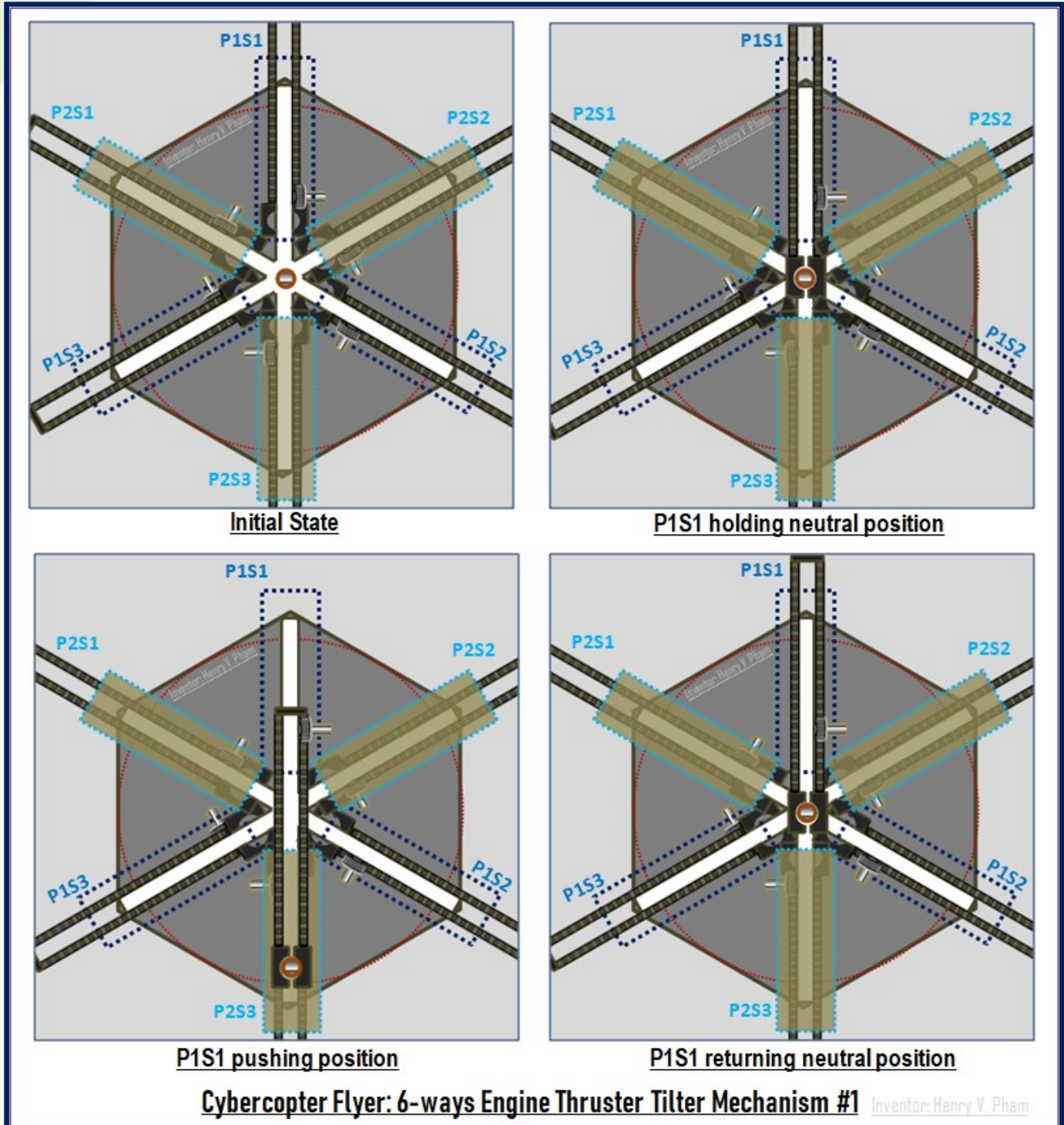

Figure-R3: Cybercopter Flyer Hexagon Engines Tilters View 1

Figure-R4: Cybercopter Flyer Hexagon Engines Tilters View 2 shows one complete move of P2S3 after the P1S1 first move. The P2S3 starts holding the pole at the center as shown in the top left drawing, and at the same time the P1S1 releases the pole and returns to its initial position as shown in the top right drawing.

Cybercopter Flyer

Now, the P2S3 starts pushing the pole upward as shown in the bottom left drawing; then P2S3 returns to neutral position to complete its move of forward direction as shown in the bottom right drawing.

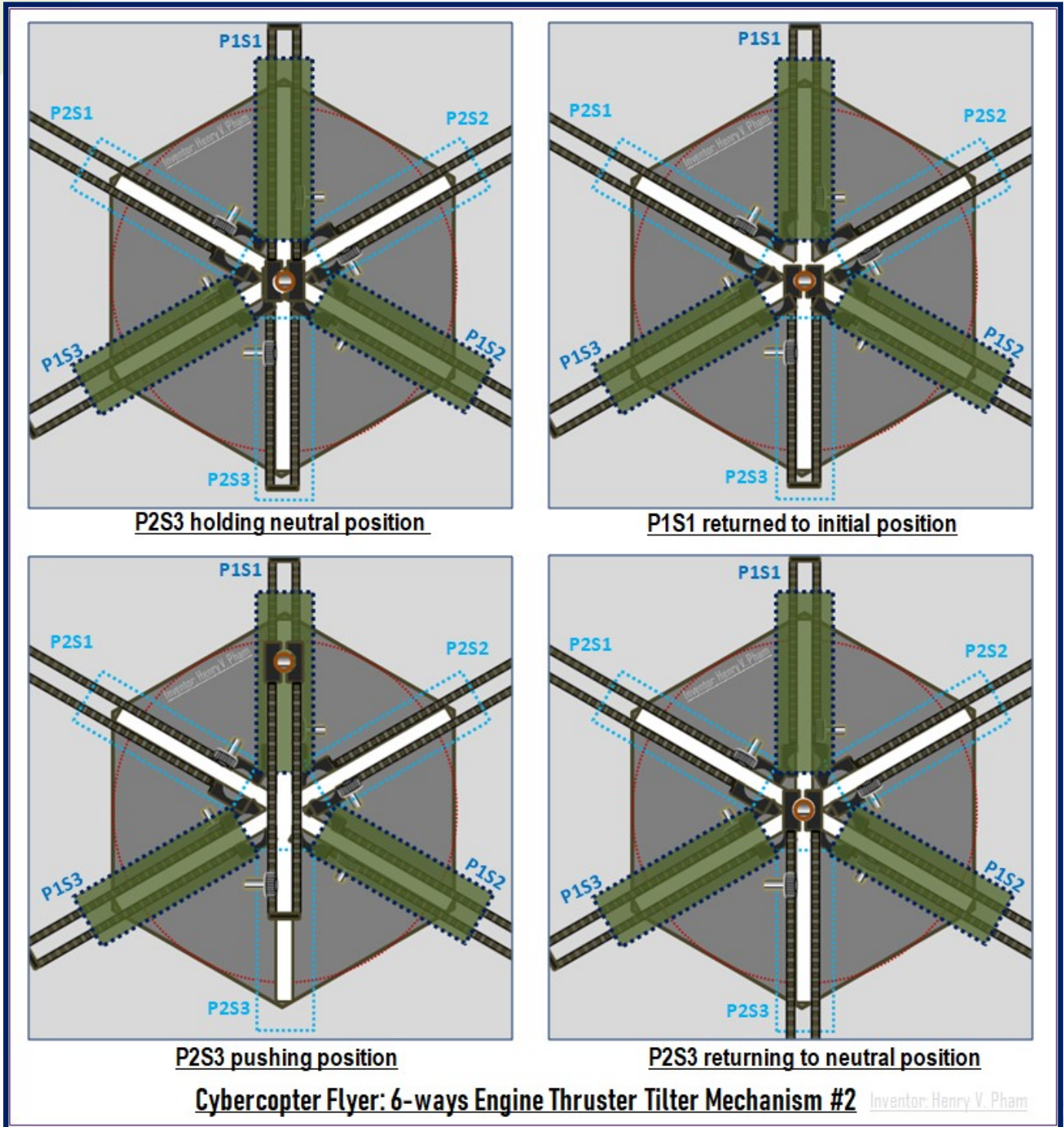

Figure-R4: Cybercopter Flyer Hexagon Engines Tilters View 2

Figure-R5: Cybercopter Flyer Hexagon Engines Tilters View 3 shows one complete move of P1S3 after the P2S3 move. The P1S3 starts holding the pole at the center as shown in the top left drawing, and at the same time the P2S3 releases the pole and returns to its initial position as shown in the top right drawing. Now,

Cybercopter Flyer

the P1S3 starts pushing the pole top-right direction as shown in the bottom left drawing; then P1S3 returns to neutral position to complete its move of top-right direction as shown in the bottom right drawing. The same mechanism works for other directions.

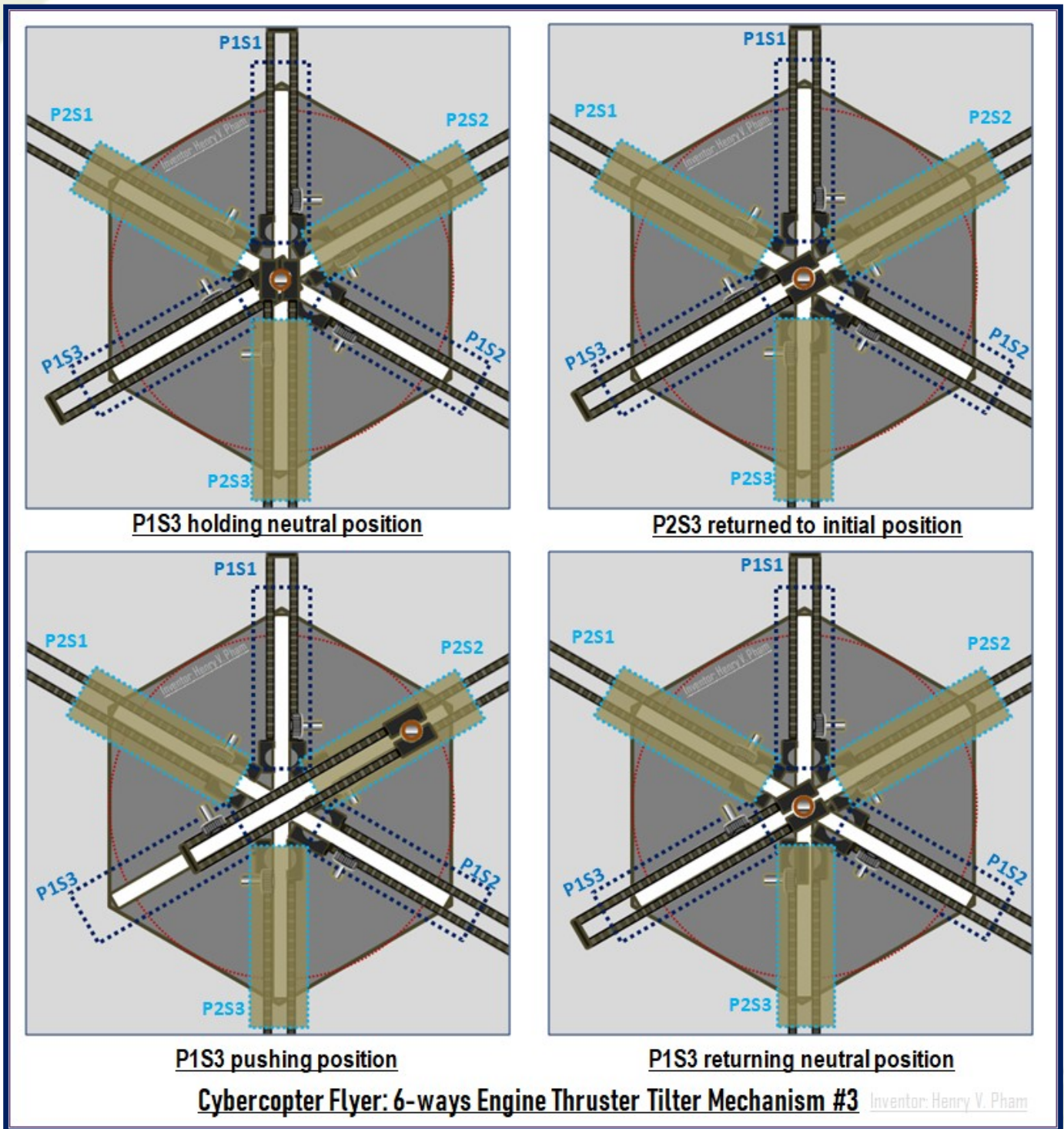

Figure-R5: Cybercopter Flyer Hexagon Engines Tilters View 3

Cybercopter Flyer

The above thruster tilter mechanism of the Hexagon Engine Thruster Tilter is just a corner of the triangle that holding the engine thruster. Now let's put all together as a system of the thruster tilter to see how this works. **Figure-R6: Cybercopter Flyer Hexagon Engines Tilter Mechanism Neutral Position** shows an engine thruster at the center which is hold by the supporters within the triangle frame shown in dash color. At neutral position, the tilter poles are stay at the center of each hexagon. When the engine tilter wants to move upward direction, the entire triangle is sliding upward which is pulled by the poles in the 3 hexagons as shown with green arrows on all 3 hexagons. When the engine tilter wants to move downward direction, the entire triangle is sliding downward which is pulled by the poles in the 3 hexagons as shown with dark blue arrows on all 3 hexagons. When the engine tilter wants to move top-right direction, the entire triangle is sliding top-right direction which is pulled by the poles in the 3 hexagons as shown with dark blue arrows on all 3 hexagons. The tilter mechanism would work the same for other directions.

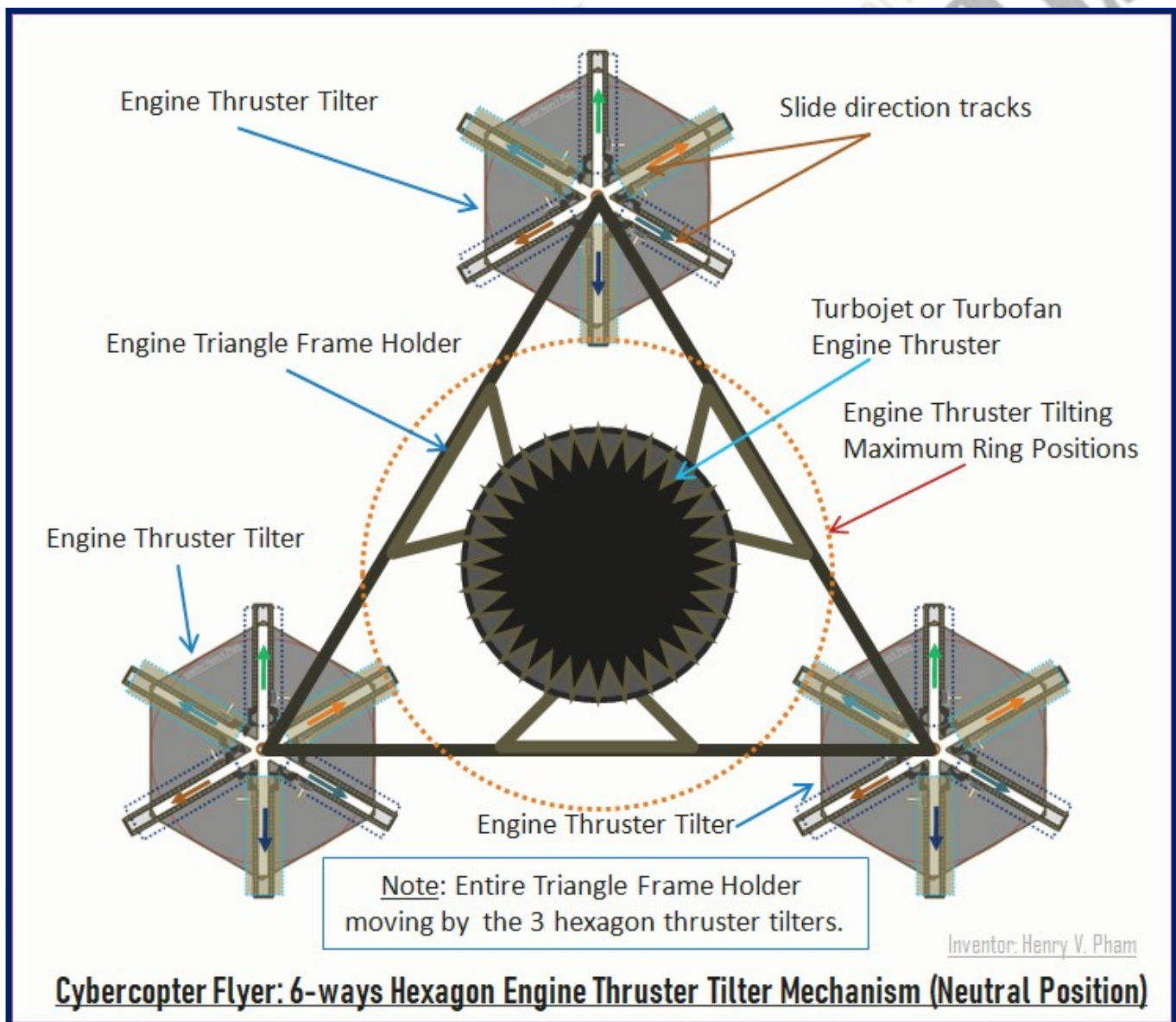

Figure-R6: Cybercopter Flyer Hexagon Engines Tilter Mechanism Neutral Position

Cybercopter Flyer

Figure-R7: Cybercopter Flyer Hexagon Engines Tilter Mechanism Operating View 1 shows the views of the engine thruster tilter moves the thruster upward direction as shown on the left drawing and downward direction as shown on the right drawing.

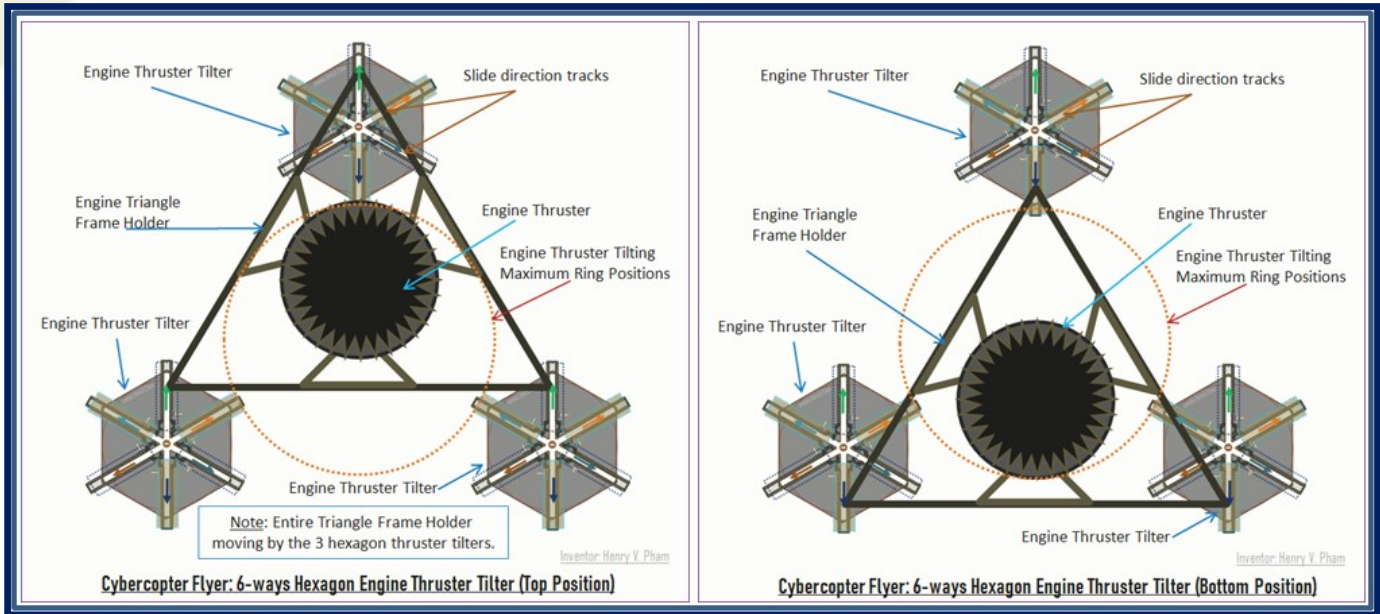

Figure-R7: Cybercopter Flyer Hexagon Engines Tilter Mechanism Operating View 1

Figure-R8: Cybercopter Flyer Hexagon Engines Tilter Mechanism Operating View 2 shows the views of the engine thruster tilter moves the thruster top-right direction as shown on the left drawing and bottom-left direction as shown on the right drawing.

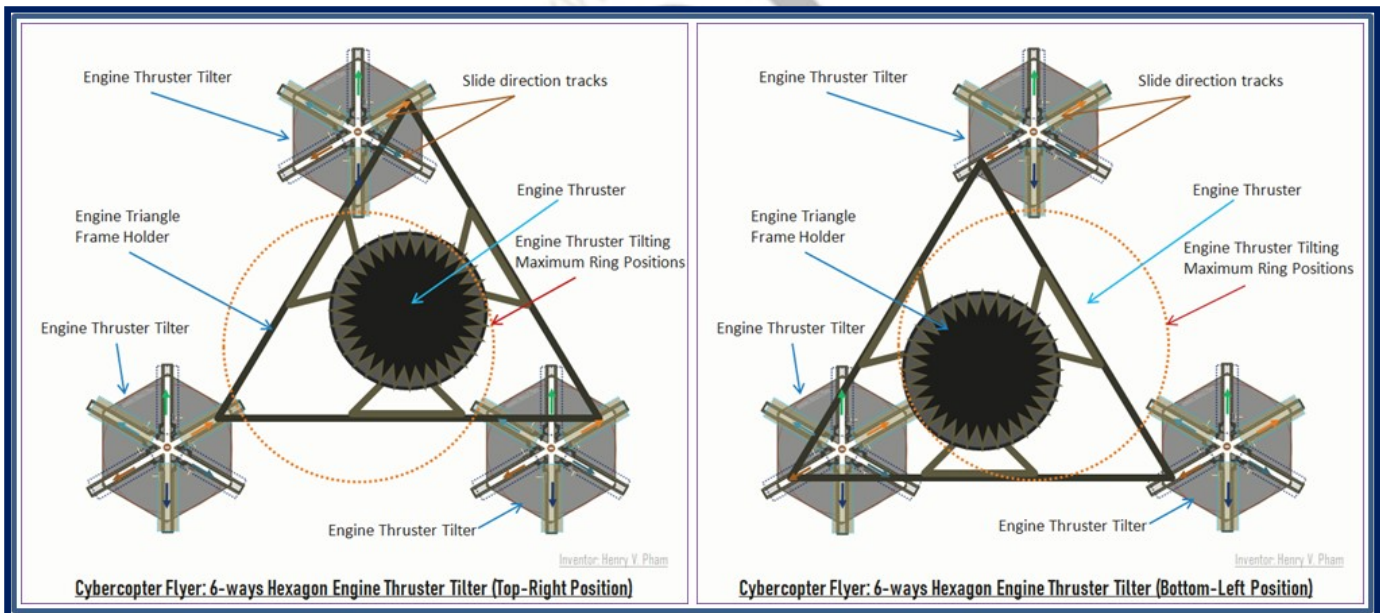

Figure-R8: Cybercopter Flyer Hexagon Engines Tilter Mechanism Operating View 2

Figure-R9: Cybercopter Flyer Hexagon Engines Tilter Mechanism Operating View 3 shows the views of the engine thruster tilter moves the thruster bottom-right direction as shown on the left drawing and top-left direction as shown on the right drawing. And of course the maximum ring positions that the thruster can

Cybercopter Flyer

move is depending on the length limit of the bars and tracks of the hexagon shapes. Note that the motors for thruster tilters are not showing detail in this invention document which is depended on the space available of the flyer around the engines; however, rope or cable with rally motors can be used in this case to pull the thruster tilter supporters.

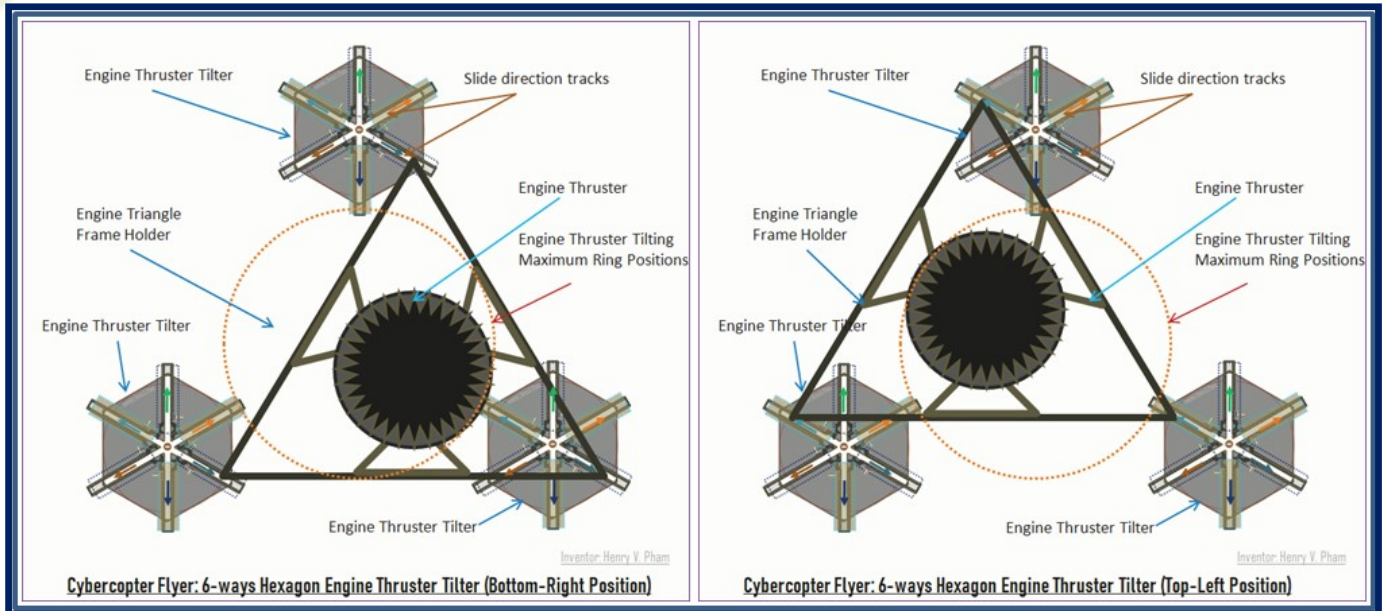

Figure-R9: Cybercopter Flyer Hexagon Engines Tilter Mechanism Operating View 3

3. The Octagon Engine Thruster Tilter

To provide more directions of the thrust for the flyers, the Octagon Engine Thruster Tilter is an expanded version of the Hexagon Engine Thruster Tilter. Figure-R10: Cybercopter Flyer Octagon Engines Tilter Mechanism below shows a sample of the hexagon thruster tilter with 4 octagon tilters at the square corner of the engine.

At neutral position, the tilter poles are stay at the center of each octagon. When the engine tilter wants to move upward direction, the entire square frame is sliding upward which is pulled by the poles in the 4 octagons as shown with green arrows on all 4 octagons. When the engine tilter wants to move downward direction, the entire square frame is sliding downward which is pulled by the poles in the 4 octagons as shown with light-aqua color arrows on all 4 octagons. When the engine tilter wants to move top-right direction, the entire square frame is sliding top-right direction which is pulled by the poles in the 4 octagons as shown with orange arrows on all 4 octagons. The tilter mechanism would work the same for other directions.

The Hexagon Engine Thruster Tilter provides 6-ways of tilting, and the Octagon Engine Thruster Tilter provides 8-ways of tilting. To have more directions of engine thruster tilting, we can easily expand from Octagon Engine Thruster Tilter to Decagon Engine Thruster Tilter for 10-ways of tilting and even more. This invention of engine thruster tilter provides the great expansion of tilting directions with stable tilting frames and mechanical that would be the great promise for the future of the aerospace industry and technology.

Cybercopter Flyer

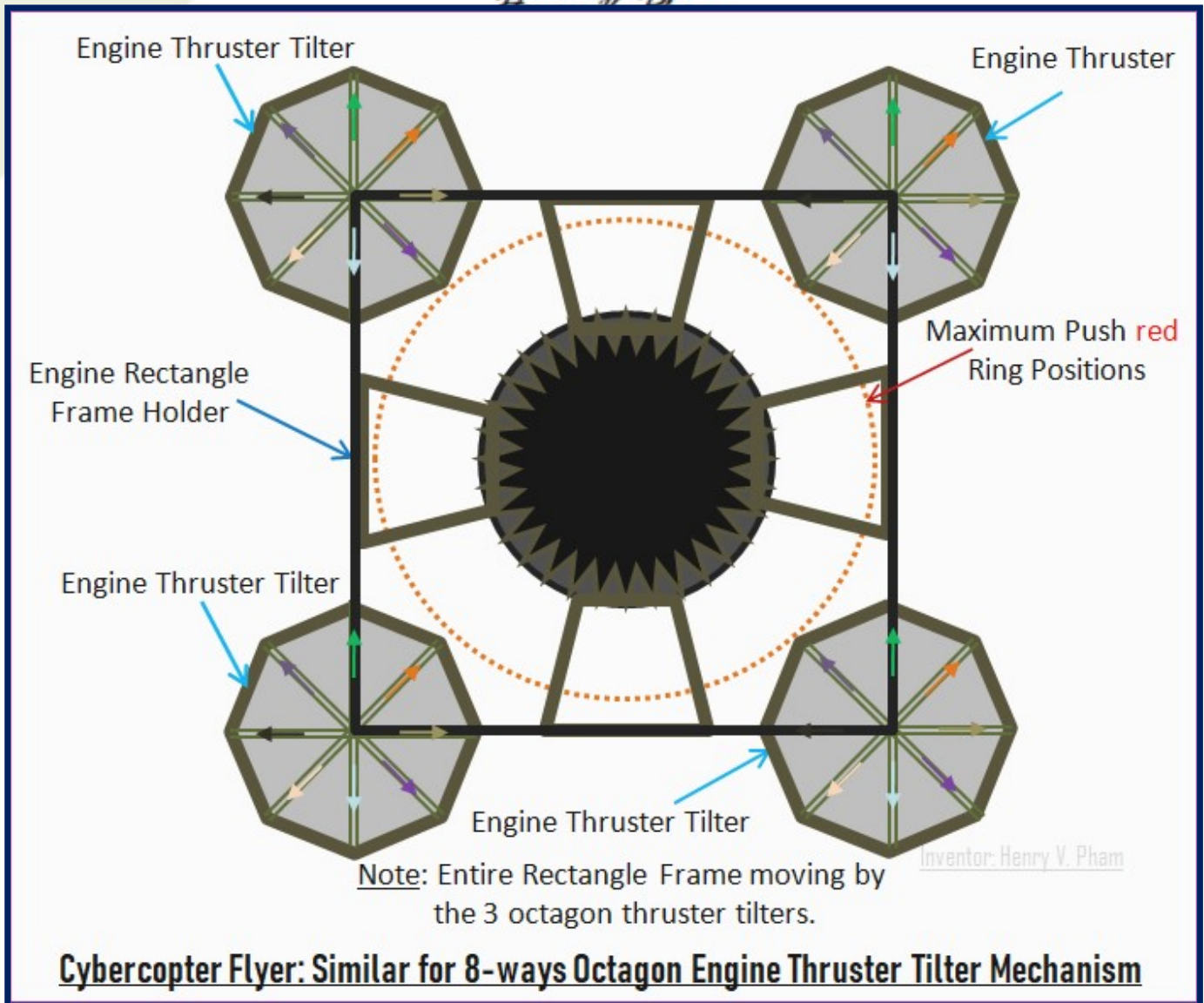

Figure-R10: Cybercopter Flyer Octagon Engines Tilter Mechanism

With the thruster tilters shown above, a simple robot arm is needed to hold the tilter pole of the thruster tilter mechanism. Figure-R11: Cybercopter Flyer Engine Thruster Tilter Pole Slide Holder below shows a sample of a robot arm to hold the pole in round shape. The robot arm would come with 2 gear bars, and each gear bar holds the half arm; the gear bars are attached as the slider as mentioned in the previous figures. Note that the motors for thruster tilters are not showing detail in this invention document which is depended on the space available of the flyer around the engines; however, rope or cable with rally motors can be used in this case to pull the thruster tilter supporters. When a gear bar slider is in its initial position, the robot arm is opened and the tilter pole can move along the white open lane as mentioned earlier and shown on this top drawing; when the gear bar slider is assigned to pull or push the tilter pole on its direction, the robot arm on this gear bar slider will close and hold the tilter pole then pull or push along the while open lane as shown on the bottom drawing of this figure.

Cybercopter Flyer

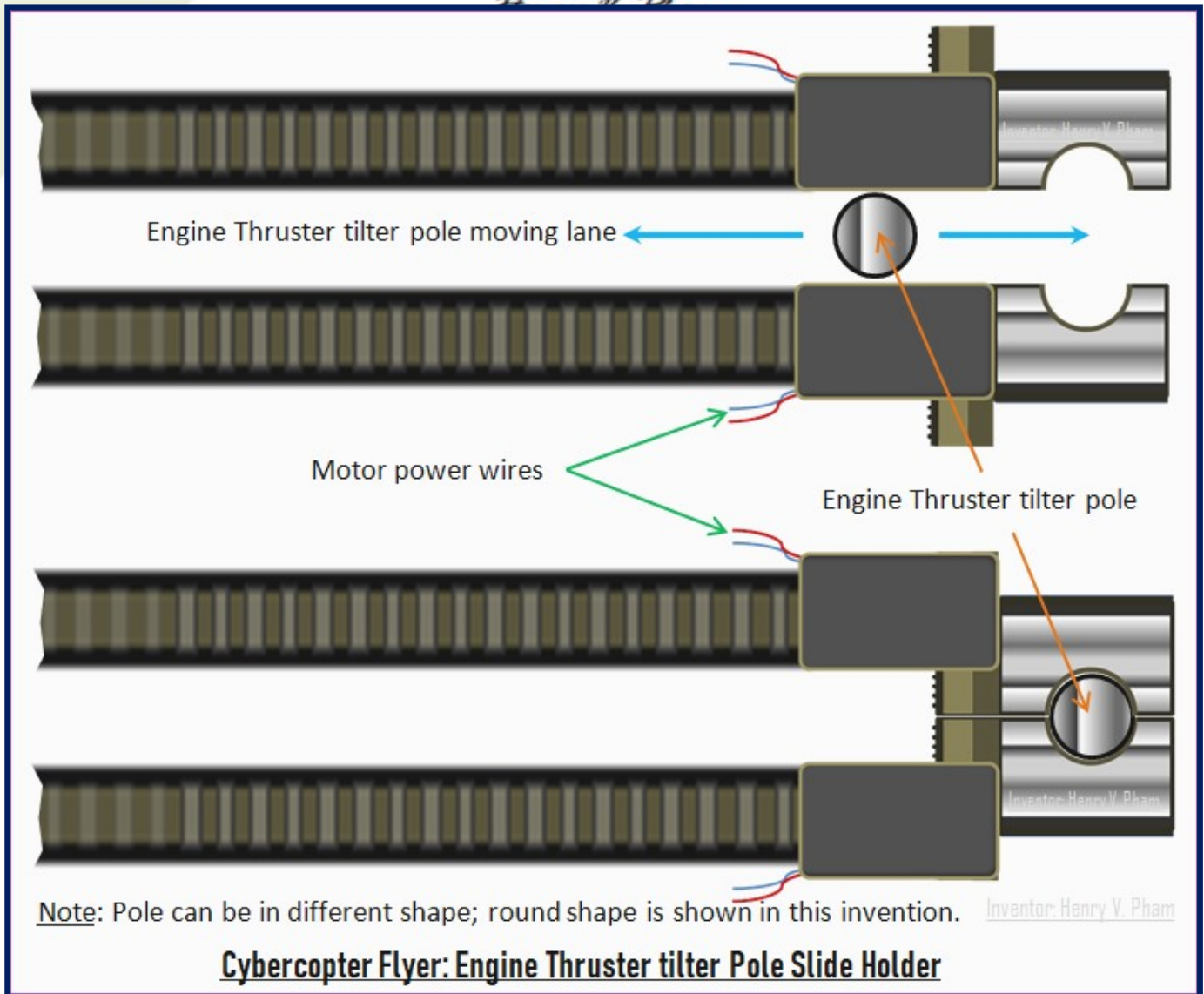

Figure-R11: Cybercopter Flyer Engine Thruster Tilter Pole Slide Holder

Figure-R12: Cybercopter Flyer Engine Thruster Tilter Pole Slide Arm below shows the sample robot arm in more detail. The top right drawing shows the outer arm with the arm thread bar which is used to pull arm to open or close by a thread motor; this drawing shows the outer arm with the bottom open shape which is half of the tilter pole shape. The drawing on the top right shows the bottom view of the outer arm with dark section which is the half open shape. The bottom left drawing shows the arm controller with inner thread motor; this arm controller holds the arm with the thread arm bar in the open thread bar slot and turns the outer arm in or out by the thread motor. The arm controller would connect to the tilter mechanism and wait for the command to hold the tilter pole for pulling or pushing on its tilting direction. The bottom right drawing shows the arm controller in top view which shows the open bar slot that would be used for the arm thread bar. The most bottom drawing shows a complete a complete robot arm without the gear bar or slider. This is a sample of robot arm for these thruster tilters; however, robot arms

Cybercopter Flyer

Henry V. Pham

are widely use in the current market; other similar robot arms that fit into these thruster tilters and are reliable and compliant with safety is also acceptable.

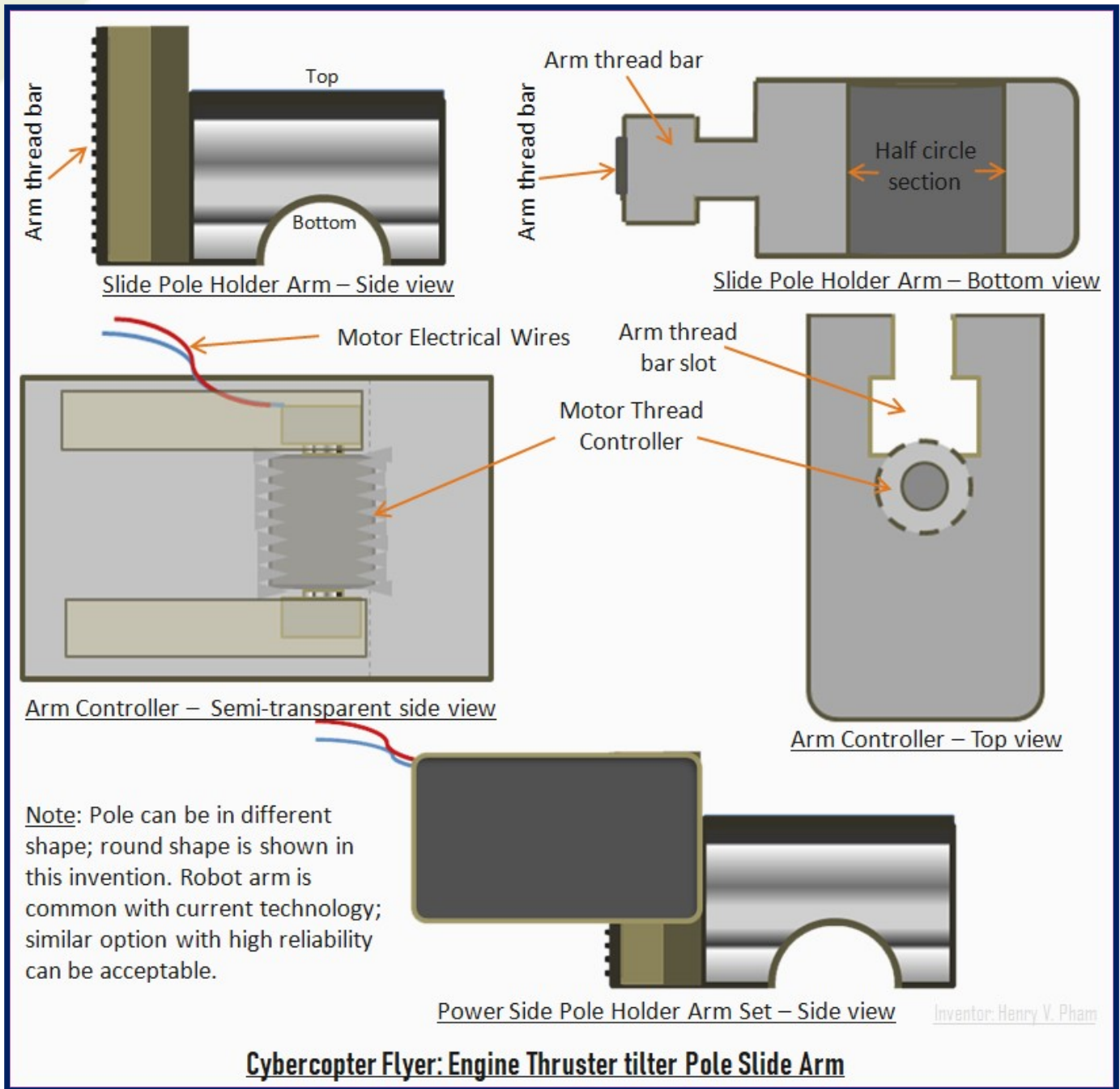

Figure-R12: Cybercopter Flyer Engine Thruster Tilter Pole Slide Arm

Cybercopter Flyer

4. The Important of Thruster Tilter for Cybercopter Flyer

The Engine Thruster Tilter is very important and critical for Cybercopter Flyer when the flyer is starting fly in fast mode that needs the 4 vertical thrusters to tilt at an angle to push the flyer forward; when the flyer is slowing down to stop for hovering, the flyer needs the 4 vertical thrusters to tilt at an angle to push the flyer backward as described in the earlier sections. However, when one engine is failed, the engine thruster tilters would do the critical job to keep the flyer balance and continue flying.

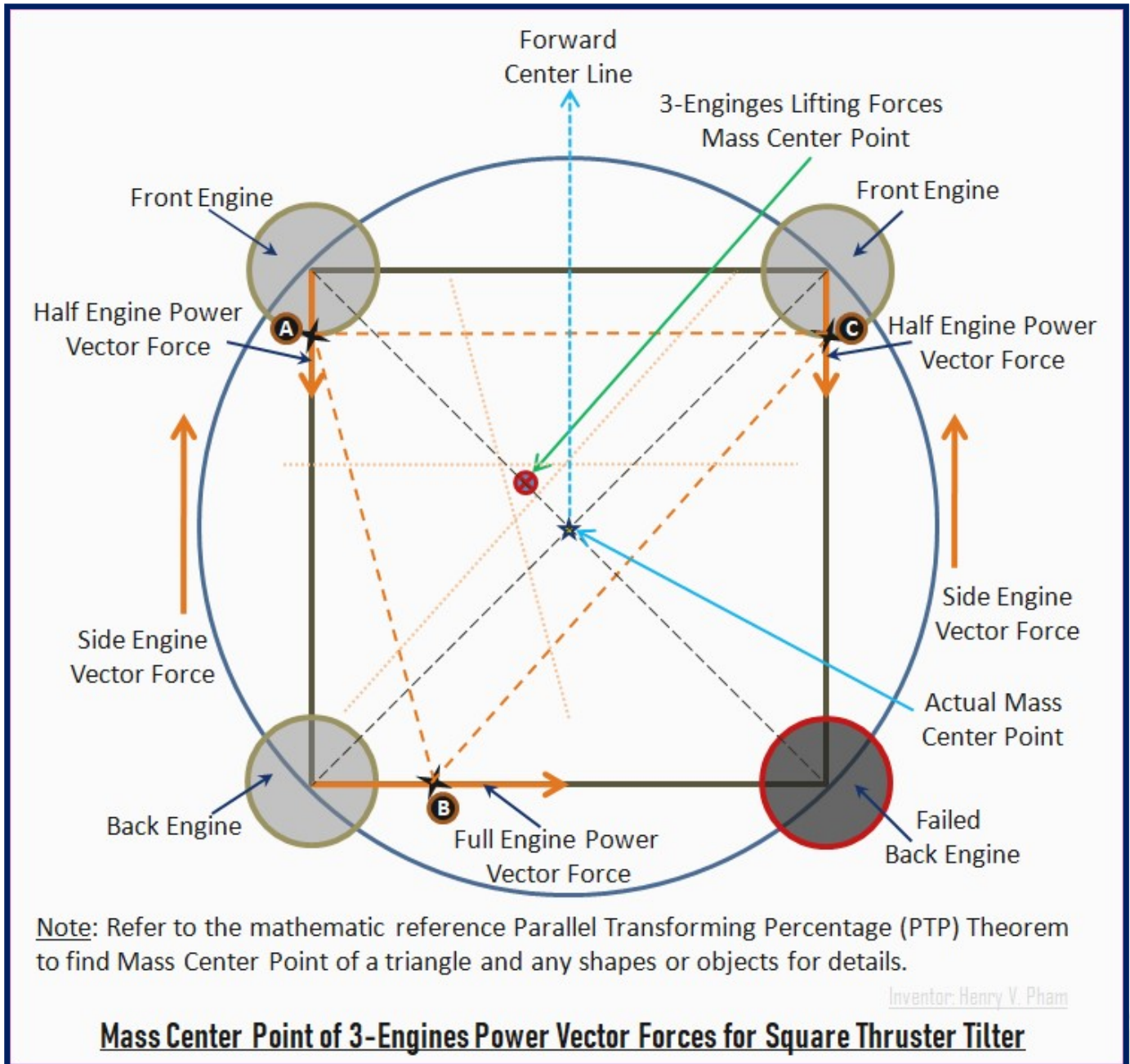

Figure-R13: Cybercopter Flyer Balance Mass Center of 3-Engines with the Square Thruster Tilter

Figure-R13: Cybercopter Flyer Balance Mass Center of 3-Engines with the Square Thruster Tilter shows the prediction balance pattern of the other 3 engine thrusters with the 4-way thruster by apply mathematic calculation

Cybercopter Flyer

based on the Mass Center Point which was mentioned in my mathematic invention "Parallel Transform Percentage (PTP) Theorem" which is shown in the references section below. The above figure shows a back engine failed in red circle, and the balance pattern of the other 3-point forces to lift the flyer. Assume the thrust powers reduced by half for both front engines, and keep full power for the back working engine; with the average of vector forces we can have the triangle ABC; this triangle is the lift-able triangle of the 3-point forces. By applying the PTP Mass Center Point for triangle, we have the red 'x' around the center is the mass center point of the lift-able triangle with the 3-point forces. Note that the small star at center is the actual mass center point of the Cybercopter Flyer by default. So, it is important to use the Engine Thruster Tilter to adjust the lift-able mass center point to closer to the actual mass center point to keep the flyer balance when one of the engines is out of service.

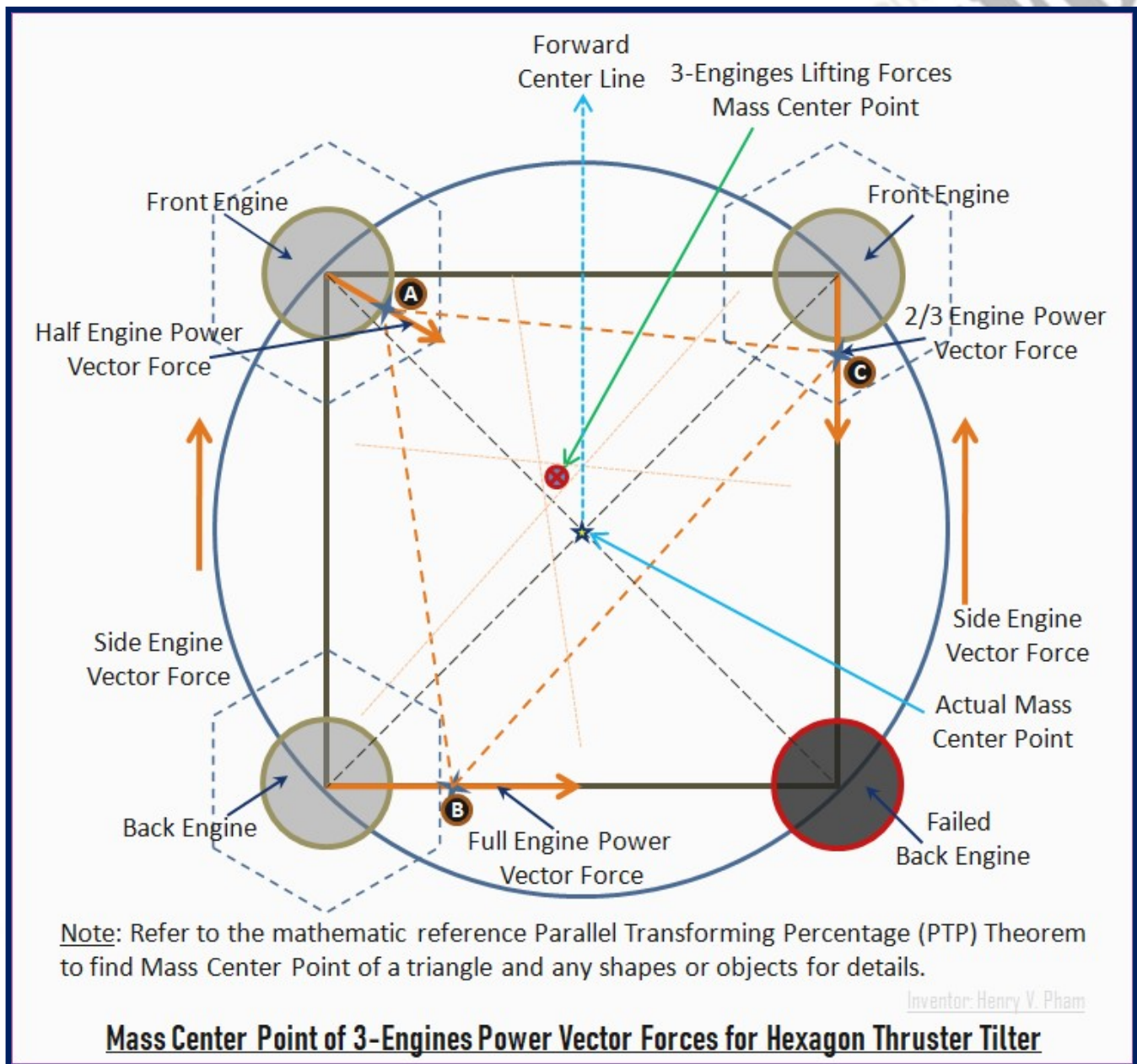

Figure-R14: Cybercopter Flyer Balance Mass Center of 3-Engines with the Hexagon Thruster Tilter

Cybercopter Flyer

Similar to the above, the 6-ways or Hexagon Thruster Tilter may bring the lift-able mass center point closer to the center line of left and right of the flyer. Figure-R14: Cybercopter Flyer Balance Mass Center of 3-Engines with the Hexagon Thruster Tilter shows the thrust pattern of the 3-point forces of the 3 working engines with the Hexagon Thruster Tilter. Bring the lift-able mass center point closer to the actual mass center point is important and critical for the Thruster Tilter mechanism and the flyer control system. With this method of find mass center point and the ability of the 3 vertical thrust working engines, the flyer control system would also need find the best to adjust the other engines either left or right side engine to be stronger or lower in power to keep the flyer balance and continue flying with 3 engines. This method of finding lift-able mass center point would be the same for a different vertical thrust engine failed in term of engine's position.

S. Cybercopter Roll-able Flyer for Military Option

The Cybercopter Flyer is also a great flyer for military which can be used for heavy duty lift up, can be used for sky diving or troop deploying in the air, can be used to patrol and visit camp to camp can also great for visiting aircraft carrier which can be flying by any personnel or high rank since the Cybercopter Flyer is invented like car driving behaviors. Beyond those activities, the Roll-able Cybercopter Flyer with option of foldable side pushing and turning engines is introduced to provide the military with a flyer that can roll in the air. Figure-S1: Cybercopter Roll-able Flyer Military Option View 1 shows a sample of Cybercopter Flyer rolling counter clockwise. The flyer would come with small top and bottom thrusts which are used to adjust the flyer to the rolling angle. When the control system of the flyer can able to tilt the flyer to the roll-able angle, the side engines will take turn to reduce or increase power thrust on each side to roll the flyer in the air. The left drawing shows the flyer rolling at 90° degrees angle at position-1 with left engine set to lowest power (~0%), and the right engine set to highest power (~100%); the flyer keep this momentum of rolling with reducing and increasing of power on each side engines synchronously; the flyer would roll to position-2 with the left engine low power (~25%) and the right engine power (~100%) at 135° degrees angle.



Figure-S1: Cybercopter Roll-able Flyer Military Option View 1

Cybercopter Flyer

Figure-S2: Cybercopter Roll-able Flyer Military Option View 2 shows the flyer continue rolling to 180° degrees angle and to 225° degrees angle. The left drawing shows the flyer rolling at 180° degrees angle at position-3 with left engine set to lower power (~25%) than the right engine, and the right engine set to higher power (~75%); the flyer keep this momentum of rolling with reducing and increasing of power on each side engines synchronously; the flyer would roll to position-4 with the left engine low power (~0%) and the right engine power (~10%) at 225° degrees angle.

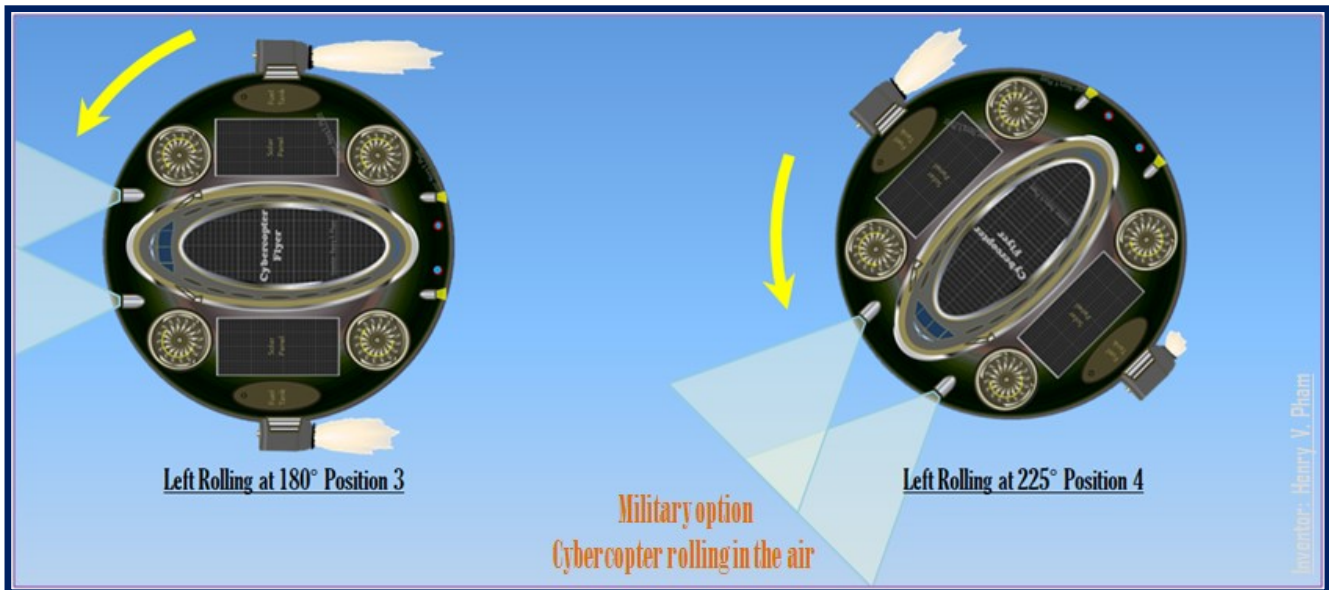

Figure-S2: Cybercopter Roll-able Flyer Military Option View 2

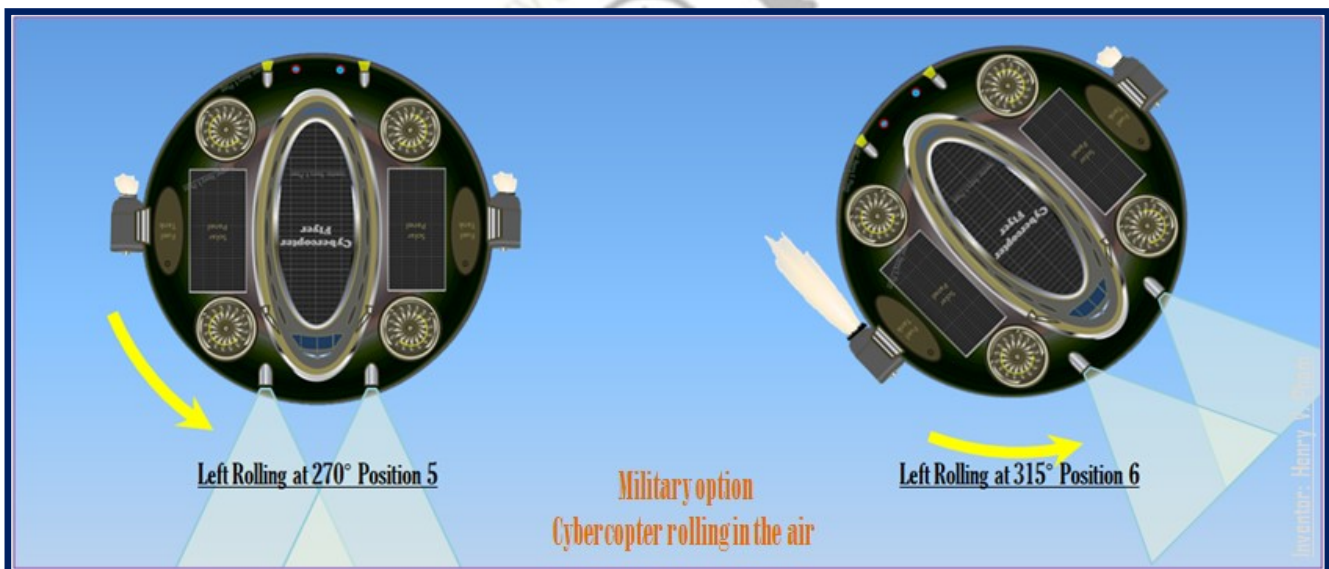

Figure-S3: Cybercopter Roll-able Flyer Military Option View 3

Figure-S3: Cybercopter Roll-able Flyer Military Option View 3 shows the flyer continue rolling to 270° degrees angle and to 315° degrees angle. The left drawing shows the flyer rolling at 270° degrees angle at position-5 with left engine set to lowest power (~0%) than the right engine, and the right engine set to lowest power (~0%); the flyer keep this momentum of rolling with reducing and increasing of power on each side

Cybercopter Flyer

engines synchronously; the flyer would roll to position-6 with the left engine low power (~0%) and the right engine power (~25%) at 315° degrees angle.

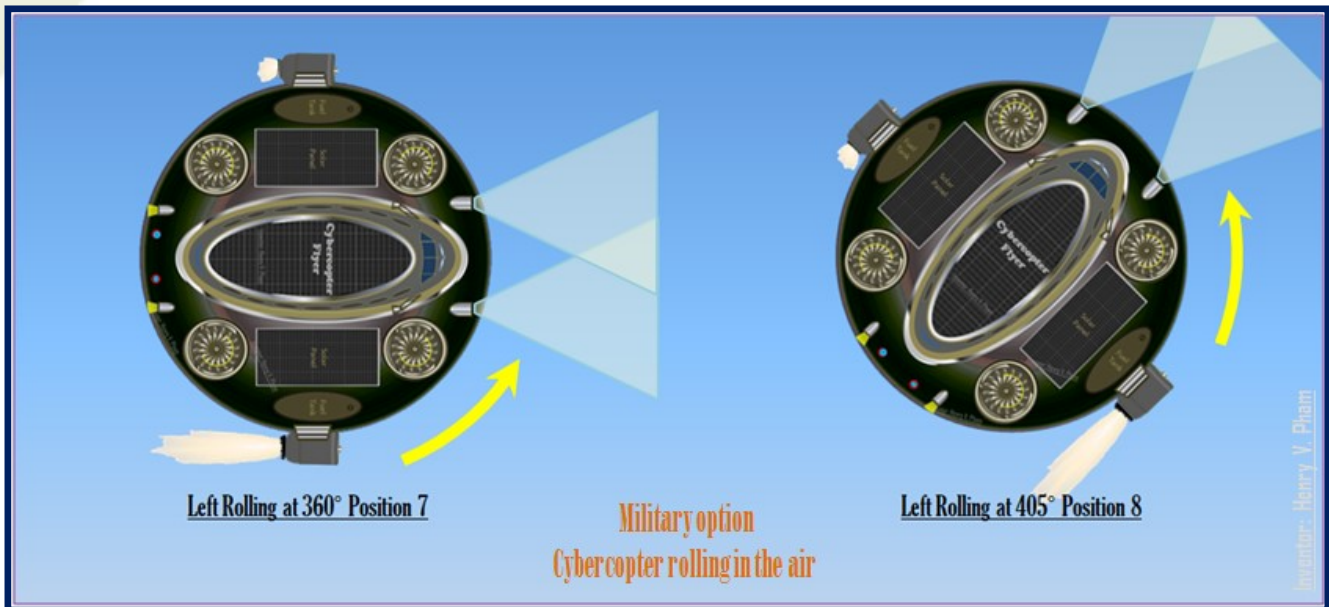

Figure-S4: Cybercopter Roll-able Flyer Military Option View 4

Figure-S4: Cybercopter Roll-able Flyer Military Option View 4 shows the flyer continue rolling to 360° degrees angle and to 405° degrees angle. The left drawing shows the flyer rolling at 360° degrees angle at position-7 with left engine set to lowest power (~0%) than the right engine, and the right engine set to low power (~50%); the flyer keep this momentum of rolling with reducing and increasing of power on each side engines synchronously; the flyer would roll to position-8 with the left engine low power (~0%) and the right engine power (~90%) at 405° degrees angle. This would be a great rolling feature for military to show rolling in the air object with the flyer and the synchronization of the engines and adjust thrusts keeping the rolling flyer balance while rolling in the air.

T. Summary

The **Cybercopter Flyer** is invented with State of The Art design like UFO shape which is intended to replace the existing helicopter and vertical takeoff and landing aircrafts or helicopters. The Cybercopter Flyer with common regular sizes to replace helicopter is about the size of the helicopter with the blades spinning around on top which could cover about 5 meters in diameter.

The Cybercopter Flyer would have 4 main lift up engines which can be turbofan, turbojet or more advanced engines; and the 2 main turning side engines which are used to turn left or right while flying, with plus of the 2 additional pushing engines on the back to help the flyer flying faster. The Cybercopter Flyer can hover more stable than helicopter with the 4 lift up engines within the pumping protection ring and much safer than helicopter, better for highway patrol, great for rescuing, stronger for lifting, good to fly for sightseeing, great for sky diving in larger shape for military versions. The Cybercopter Flyer can be built with bigger shape and have up to 12 engines which can be used for heavy duty carrying or large and heavy transportation services with great advantage of vertical takeoff and landing with the great standier.

Cybercopter Flyer

The Cybercopter Flyer would come with many different versions. The Electrical Powered Cybercopter Flyer version with only turbofan engines, use only electrical power which can be charged anywhere with electrical power provided and with solar power with solar panel on top surface of the Cybercopter Flyer. The Hybrid Powered Cybercopter Flyer version would come with the 4 lifting up turbofan engines, and the side turning and back pushing engines can be turbojet engines which would use liquid fuel to burn the intake air for propulsion. The Liquid Fuel Cybercopter Flyer version would come with all turbojet engines for bigger shapes which are used to burn the intake air for propulsion.

The Cybercopter Flyer would be built to fly like driving a car to keep the normal driving behaviors with steering wheel yoke and pedals; push on the speed pedal to fly forward; push on the brake pedal to slow down; and plus an up/down joystick for takeoff and landing. With the recommendation of replaceable engine modules for any aircraft, any airplane or any flyer; the Cybercopter Flyer is the great promise for the future of air transportation with vertical takeoff and landing which is in high demand for the human world today for personal use with easy flying, good for border police patrolling, great for high rank military personnel whom needs to fly for patrolling or for camp or aircraft carrier visiting, and great to replace all the duties that are currently used with the existing helicopters.

U. References

1. New words are introduced in this invention document, 'Elevadoor' is the door in the elevator, and 'Liftier' is the Lift-i-er lifting system, 'Standier' is stand of the machine with leg that can stand with control of mechanical (Stand-i-er).
2. Below are some references to explore more about fundamental aerospace engines of Turbofan, Turbojet.
 - a. https://eng.libretexts.org/Bookshelves/Aerospace_Engineering;
 - b. [https://eng.libretexts.org/Bookshelves/Aerospace_Engineering/Fundamentals_of_Aerospace_Engineering_\(Arnedo\)/06%3A_Aircraft_propulsion/6.03%3A_Types_of_jet_engines](https://eng.libretexts.org/Bookshelves/Aerospace_Engineering/Fundamentals_of_Aerospace_Engineering_(Arnedo)/06%3A_Aircraft_propulsion/6.03%3A_Types_of_jet_engines);
 - c. [https://eng.libretexts.org/Bookshelves/Aerospace_Engineering/Fundamentals_of_Aerospace_Engineering_\(Arnedo\)/06%3A_Aircraft_propulsion/6.03%3A_Types_of_jet_engines/6.3.01%3A_Turbojets](https://eng.libretexts.org/Bookshelves/Aerospace_Engineering/Fundamentals_of_Aerospace_Engineering_(Arnedo)/06%3A_Aircraft_propulsion/6.03%3A_Types_of_jet_engines/6.3.01%3A_Turbojets);
 - d. [https://eng.libretexts.org/Bookshelves/Aerospace_Engineering/Fundamentals_of_Aerospace_Engineering_\(Arnedo\)/06%3A_Aircraft_propulsion/6.03%3A_Types_of_jet_engines/6.3.02%3A_Turbofans](https://eng.libretexts.org/Bookshelves/Aerospace_Engineering/Fundamentals_of_Aerospace_Engineering_(Arnedo)/06%3A_Aircraft_propulsion/6.03%3A_Types_of_jet_engines/6.3.02%3A_Turbofans);
3. Mass center is very important for flying objects; the following mathematic reference which is used to find mass center point for triangle and for any objects which was introduced in my mathematic invention that has been posted on the main website, www.TheCloudOSCenter.com and click on 'Details' link under "10. Invention Title: Parallel Transforming Percentage (PTP) Theorem" section. The below **Figure-Ref: Find Mass Center Point of Triangle** shows how to find mass center point of any triangle. Where
$$a_1 = 70.71\%(a) - [a - 70.71\%(a)] - [a - 70.71\%(a)] = 3[70.71\%(a)] - 2a = a[3 \cdot 70.71\% - 2] = 12.13\%(a);$$
$$b_1 = 70.71\%(b) - [b - 70.71\%(b)] - [b - 70.71\%(b)] = 3[70.71\%(b)] - 2b = b[3 \cdot 70.71\% - 2] = 12.13\%(b);$$
$$a_1 = 70.71\%(c) - [c - 70.71\%(c)] - [c - 70.71\%(c)] = 3[70.71\%(c)] - 2c = c[3 \cdot 70.71\% - 2] = 12.13\%(c);$$

Cybercopter Flyer

Similarly, $a_2 = 12.13\%(a_1)$; $b_2 = 12.13\%(b_1)$; $c_2 = 12.13\%(c_1)$; and $a_n = 12.13\%(a_{n-1})$; $b_n = 12.13\%(b_{n-1})$; $c_n = 12.13\%(c_{n-1})$;

And **Figure-Ref2: Laws of Mass Center Point** shows the Laws of Mass Center Point which can be applied for any object.

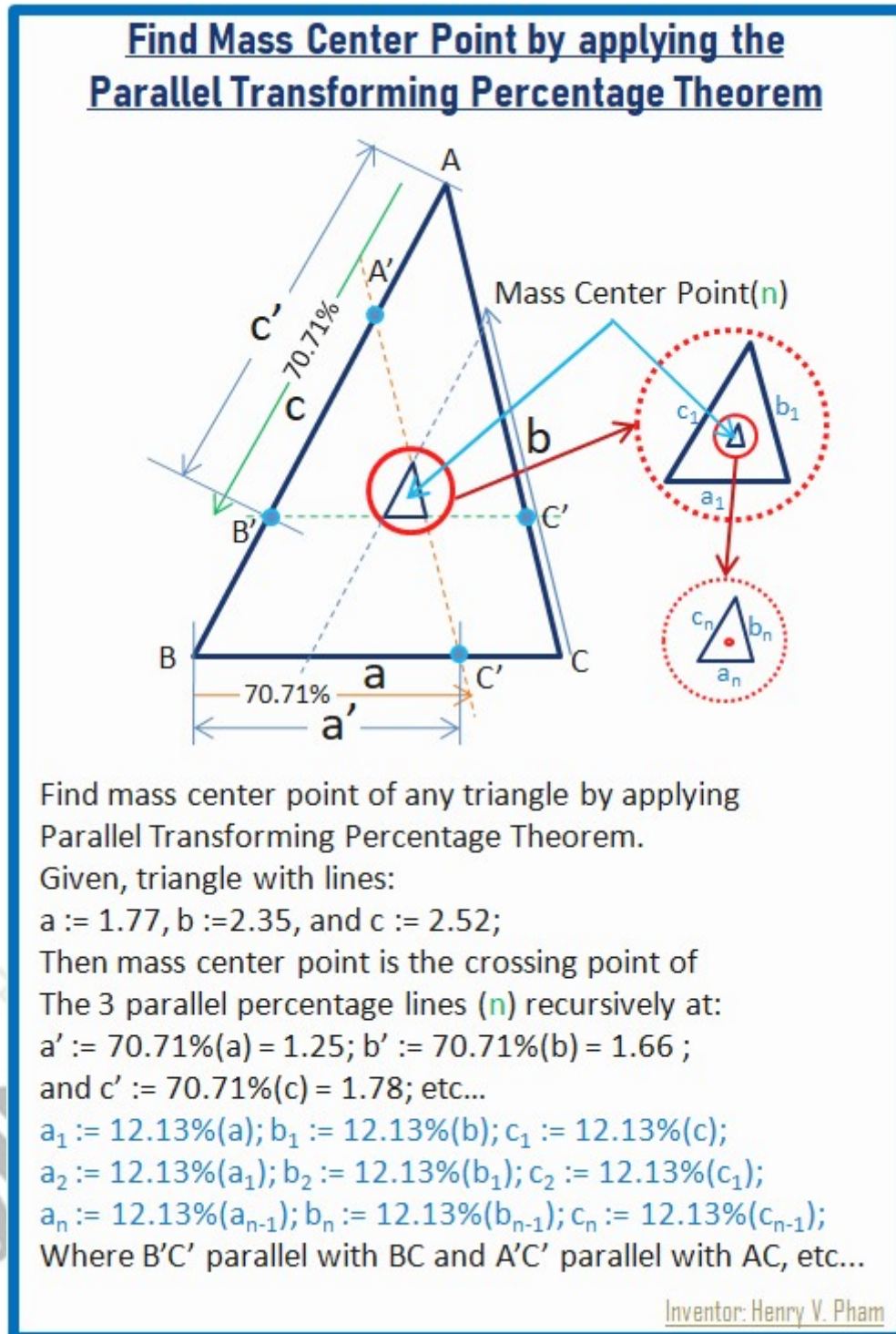

Figure-Ref1: Find Mass Center Point of Triangle

Cybercopter Flyer

Henry V. Pham

Laws of Mass Center Point

Mass center point of a shape is the crossing point of all the mass center lines, and recursively for the smaller shape, the shape that is formed by the outer shape when all the mass center lines are crossing at the center.

Mass center point of a triangle is the crossing point of the 3 mass center lines, the lines that are paralleled with their own base lines at 70.71% respectively, and recursively for the smaller triangle, the triangle that is formed by the outer triangle when the 3 mass center lines of the outer triangle are crossing at the center with the sides equal to 12.13% of the outer triangle sides, respectively (note: apply for same material, same thickness and same density for exact center point).

Mass center point of an object is the crossing point of all the mass center planes, and recursively for the smaller object, the object that is formed by the outer object when all the mass center planes are crossing at the center.

Hint: Mass center line is the balance of weight line of a shape or an object.

[Inventor: Henry V. Pham](#)

[Main website: TheCloudOSCenter.com](http://TheCloudOSCenter.com)

Figure-Ref2: Laws of Mass Center Point

Cybercopter Flyer

Henry V. Pham

V. Biography



About myself, my full name is Henry Viet Pham, original name was 'Viet Hong Pham', changed in 1996 when obtained U.S. citizenship, and currently live in Anaheim, California. I am a father of 3 sons, Alexander Le Pham, Andrew Le Pham, and Harry Quoc Pham and my wife Celine Nguyet Tran. I was born in Vietnam at Dang Nang city in 1972/08/23, then moved to my grandfather's hometown with the family right after the South Vietnam collapsed in 1975 and grown up at Binh My, Binh Son, Quang Ngai; and I came to United States in 1991 as a military and political immigrant with my father and family members. My father Nu Pham who served as a Lieutenant in military during Vietnam War in 1975, and my mother is Thong Thi Tran with my sisters are Nguyet Thi Pham, Jessie Nga Pham and Tiffany Tuyen Pham, and my brothers are Duc Hong Pham, Kevin Tri Pham, Danny Phuc Pham, and Andy Quy Pham.

About Education, I came to United States after finished my high school at TPTH Binh Son in 1989 at Quang Ngai, Vietnam; and I continued my education right after came to U.S. and I got my Bachelor Degree in Electrical and Computer Engineering at Calpoly Pomona, California in 1998. I am interested in Engineering and Science, and I have done many researches and self-study since I graduated in 1998 and continue researching and inventing with total of 13 inventions which have been submitted for patents from June 2021 to September 2024, and I still have many other inventions to work on and open the Cloud OS Company for business.

About my works and inventions, I have over 25 years of professional experience in high technology industry since 1998. I have worked for Eden Airport Ground Service Company in Los Angeles Airport in 1995; worked for Caltrans in 1997; worked for Raytheon, a defense company

Cybercopter Flyer

from year 1998 to 2005; worked for Marshal 8e6, an internet security company from year 2006 to 2010; worked for Pace America, a Satellite Set Top Box in 2010; and worked for Western Digital, a storage technology company, from year 2010 to 2024. I am a sole inventor of a total of 13 inventions which have been submitted from June 2021 to September 2024 as followings.

1. Invention Title: New Way to protect WiFi Network from Hackers – Submission with U.S. Patent PCT No.: 29/788,607; Submitted on: 2021/07/01; and resubmitted on 2024/02/27 to WIPO international office with U.S. Patent PCT No.: PCT/US24/17533 and International Patent: PCT/IB2024/000110;
2. Invention Title: THE G-CODE – First submission with U.S. Patent PCT No.: 29/806,573 => then resubmitted with PCT/US22/70704; and International Patent: PCT/IB2022/000112; Submitted on: 2021/09/03;
3. Invention Title: The Cloud OS – Operating System – Submission with U.S. Patent PCT No.: PCT/US21/71689; and International Patent: PCT/IB2021/000683; Submitted on: 2021/10/02;
4. Invention Title: The LPS – Local Positioning System – Submission with U.S. Patent PCT No.: PCT/US21/72562; and International Patent: PCT/IB2021/000949; Submitted on: 2021/11/23;
5. Invention Title: Greatest Performance Hard Drive (G-Drive) – Submission with U.S. Patent PCT No.: PCT/US21/72563; and International Patent: PCT/IB2021/000961; Submitted on: 2021/11/23;
6. Invention Title: Cell eMap Live Updates System – Submission with U.S. Patent PCT No.: PCT/US22/79368; and International Patent: PCT/IB2022/000685; Submitted on: 2022/11/07;
7. Invention Title: LPS Navigation System – Submission with U.S. Patent PCT No.: PCT/US22/79369; and International Patent: PCT/IB2022/000671; Submitted on: 2022/11/07;
8. Invention Title: Emergency Traffic Lights Routing System – Submission with U.S. Patent PCT No.: PCT/US22/82343; and International Patent: PCT/IB2022/000791; Submitted on: 2022/12/23;
9. Invention Title: G-ROUTING ALGORITHM METHODOLOGY -- Submission with U.S. Patent PCT No.: PCT/US22/82347; and International Patent: PCT/IB2022/000800; Submitted on: 2022/12/23;
10. Invention Title: Parallel Transforming Percentage Theorem -- Submission with U.S. Patent PCT No.: PCT/US23/77057; and International Patent: PCT/IB2023/000611; Submitted on 2023/10/23;
11. Invention Title: Auto Following Motion Security Camera -- Submission with U.S. Patent PCT No.: PCT/US24/13660; and International Patent: PCT/IB2024/000177; Submitted on: 2024/01/31;
12. Invention Title: Wall Security Camera System -- Submission with U.S. Patent PCT No.: PCT/US24/13663; and International Patent: PCT/IB2024/000096; Submitted on: 2024/01/31;
13. Invention Title: OH SMART AIRPORT -- Submission with U.S. Patent PCT No.: PCT/US24/43532; and International Patent: PCT/IB2024/000451; Submitted on: 2024/08/23;

Cybercopter Flyer

The “Cybercopter Flyer” and “Touch Slide & Landing Board for Aircraft Carrier” inventions are completed and intended to submit on 2024/10/23 for patents. My other inventions are listed as followings, “Hybrid Air & Rubber Cells Layer Tire” which is intended to replace current tire to help prevent flat tires, “Emergency Cylinder Helical Stair” which is used in OH SMART AIRPORT and for commercial use for personal and emergency purposes, “Personal One Step Escalator” which is intended to provide personal use like elevator in compact space, “Smart Cart Gear Belt System” which is used in OH SMART AIRPORT and intended to use for commercial for Smart Cart Exchanger, “Transpond License Plate” which is intended to use for tracking license plate within a desired distance, “Auto Tracking Target Network Security Cameras System” which is intended to use in the crowd areas like airport to follow and track the suspect/target for crowd security camera system, “Robot Medical Doctor” which is intended to help family doctors and hospital to check up patients faster with better medical statistic data with built-in Machine Intelligence (MI), and direct business related inventions, “Matrix Base Keyboard” to prevent wire/wireless keystrokes logger and “One Round Chamber” for data storage hard drive (one of my invention ‘Greatest Performance Hard Drive’) tester.

About my business, the Cloud OS Company (website: www.TheCloudOSCenter.com) business uses mainly Invention #3: The Cloud OS – Operating System, Invention #5: Greatest Performance Hard Drive (G-Drive), and Invention #9: G-ROUTING ALGORITHM METHODOLOGY. The Cloud OS Company business brings the world to the next level of World Computing Infrastructure Modern with the main purposes to secure users’ data and secure entire computer networking around the world or the World eWeb with the new technology of Neighbor-to-neighbor checking methodology and Neighbor-to-neighbor routing technology, and applying the new dynamic protocol technology for data transferring with the high secure of the 4K Number Encryption. And there are my other 3 businesses related websites www.TheGCODECreator.com which is used for the G-CODE labels/profiles/products/logos creator application; www.ThePatrolCircle.com which is used to patrol the points of interests for security camera system with Patrol Circle Unmanned Aircraft; and www.TheCybercopterFlyer.com which is used for Cybercopter Flyer, the Cybercopter flyer is intended to replace the current helicopters and for future of aviation transportation in circle shape like UFO flyers which can support both turbofan and turbojet engines with cell fuel and solar energy.